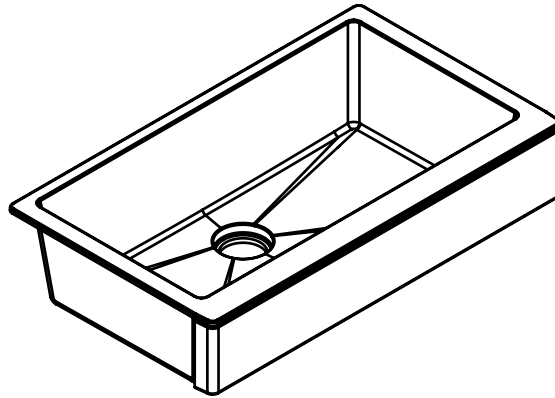


## Installation Instructions

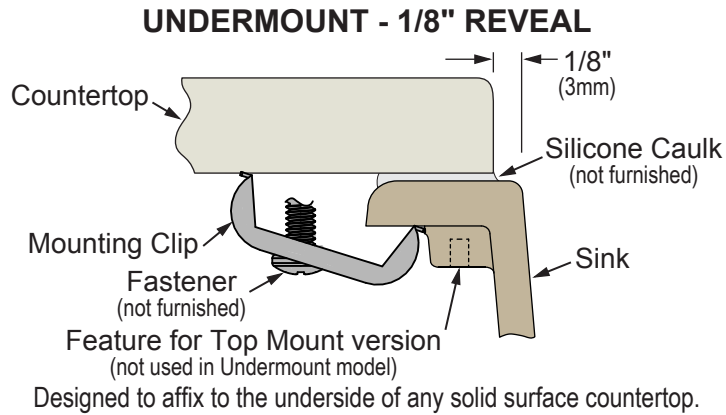
# Undermount Quartz Apron Sinks



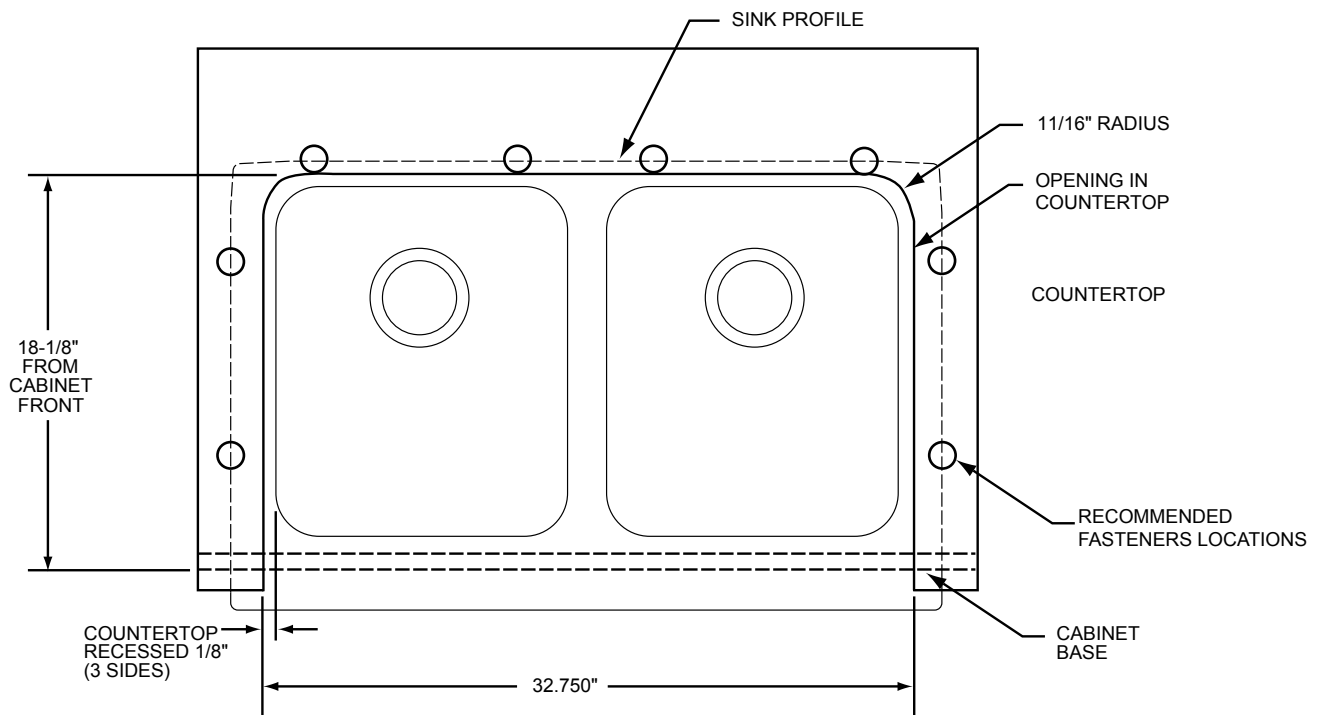
### CAREFULLY READ THESE INSTRUCTIONS BEFORE YOU BEGIN.

- For Experienced and Professional Installation Only.
- Follow all local standards and codes.
- **For granite, quartz, hardwood, or solid surface type counter top only.**
- This apron front sink is specially designed to fit in a standard 36 inch cabinet. A custom cabinet will be required for any larger size cabinet to be used with this sink. Please provide the cabinet maker with the actual sink to be installed prior to cabinet fabrication.
- Proper installation requires a coordinated effort including advanced dialog between the designer (or customer), the cabinet maker, the countertop fabricator and the sink installer during the design and installation phase.
- **WARNING:** Due to the custom nature of this type of installation, no cutout template is included. It is recommended that the sink is installed with a 1/8" countertop reveal as illustrated in Figure 1. It is further recommended that the installer(s) discuss this with the customer and agree that this finished appearance is the desired effect. Elkay Manufacturing Company is not responsible for improper sink or countertop installations.
- Figure 2 provides reference dimensional information for establishing a cutout in relationship to the cabinet.

# Installation Instructions

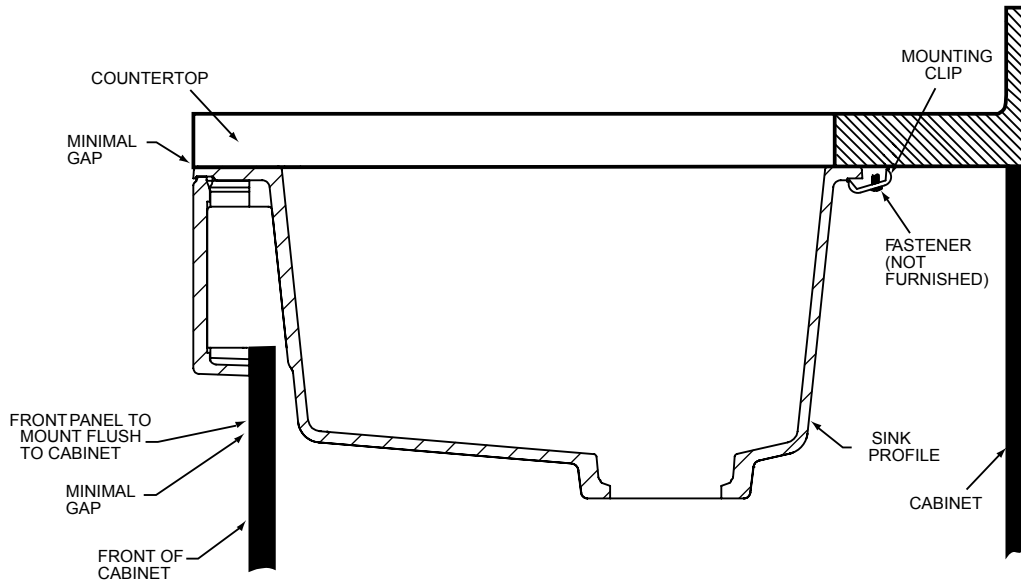


**FIGURE 1**

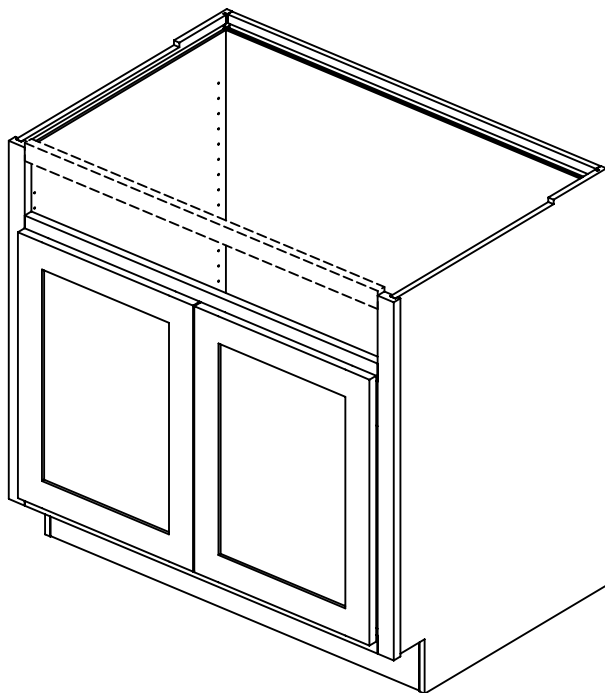


**FIGURE 2**

# Installation Instructions



**FIGURE 3**



**FIGURE 4**

NOTE: If Apron Front Sink is installed in its minimum (36 inches) recommended cabinet, side clips are not required as sink can rest on cabinet side walls.

Clips and fasteners are still required on back of sink.

Elkay recommends that the sink be placed on top of the cabinet after the false drawer front and upper bracing is removed.

The sink can then be traced onto the side walls of the Cabinet to show what material must be removed.

Elkay recommends removing material 1/16 of an inch at a time until the desired look is achieved between the cabinet, sink and countertop.

# Installation Instructions

## CARE AND CLEANING GUIDE

Elkay Quartz™ sinks were created for a lifetime of easy care. Just follow the simple guidelines listed below.

### Routine Care

Most dirt and stains: Wipe with a damp cotton cloth/sponge and soapy water. Towel dry with a cotton cloth. *It is recommended that you clean your sink prior to first use.*

Stubborn stains and water marks: Wipe with a Mr. Clean® Magic Eraser® and either water or a 50/50 white vinegar and water solution. Towel dry with a cotton cloth.

Difficult stains: Use a 3M Scotch-Brite™ Heavy Duty Scour Pad with either water, 50/50 white vinegar and water solution or non-abrasive cleaner. Start cleaning in a circular motion with a constant pressure over the area of the stain, rinse thoroughly with water and dry with a cotton cloth. Let dry 5-10 minutes. If stain persists, repeat.

MR CLEAN and MAGIC ERASER are trademarks of The Procter & Gamble Company. 3M and SCOTCH-BRITE are trademarks of 3M Company.

## Preventing Damage

•Avoid exposing an Elkay Quartz sink to strong chemicals, such as paint removers, oven cleaners, etc. If contact occurs, quickly flush the surface with water. Do not use straight or undiluted bleach solution.

•Do not use any abrasive cleaning products, scouring pads or steel wool.

•Do not use caustic solutions containing ammonia or alkalis. Examples include certain bath and drain cleaner products.

•On a weekly basis, spray quartz Rejuvenator evenly onto the clean sink surface. Wipe with soft cloth to uniform sheen. Let product completely dry on sink surface.

•One quartz Rejuvenator sample is supplied with each quartz sink. For re-order please visit your local supplier.

## ELKAY LIMITED LIFETIME QUARTZ SINK WARRANTY

Elkay warrants to the original purchaser of an Elkay Quartz sink that Elkay will, at its option, replace or repair, without charge, such product if it fails due to a manufacturing defect for a lifetime of normal residential use. Product replacement does not include transportation cost or labor installation cost. This warranty covers only Elkay Quartz drop-in sinks installed in a conventional countertop surface and Elkay Quartz undermount sinks installed in a granite, quartz, hardwood, or solid surface type counter top only and applies to residential installations only. Elkay reserves the right to examine product in question and its installation prior to replacement.

### WASTE FITTINGS AND ACCESSORIES ARE NOT WARRANTED OTHER WARRANTY CONDITIONS ON SINKS

This warranty applied to sinks purchased after August 1st 2007 as shown on the purchaser's dated receipt. Our warranty does not cover product failure or damage caused by abusive treatment, misuse, environmental factors, normal wear including dents and scratches, improper care and cleaning, use of aggressive and abrasive cleaners, damage due to handling or failure to follow the recommended vprocedures for installation, care and maintenance as detailed in the installation and care guide provided with every sink. This warranty is extended only to the original consumer purchaser of the product. This warranty does not cover shipping costs, labor costs, or any other charges for such items as installation or replacement of the sink, diagnosis or replacement of any faucet or component part, or any other expense or loss.

**All incidental or consequential damages are specifically excluded. No additional warranties, express or implied are given, including but not limited to, any implied warranty of merchantability or fitness for a particular purpose.**

Some states do not allow the exclusion or limitation of incidental or consequential damages or limitations on how long an implied warranty lasts, so the above limitations or exclusions may not apply to you. This warranty gives you specific legal rights, and you may also have other rights which vary from state to state.

### TO OBTAIN SERVICE UNDER WARRANTY

1. Write to: Elkay Manufacturing Company  
Attention: Consumer Services  
2222 Camden Court  
Oak Brook, IL 60523
2. Include a letter containing the following information:
  - a.Date of purchase and installation
  - b.Proof of Purchase (copy of original dated invoice)
  - c.Description of nature of defect
  - d.Model number or description of model and/or component part if possible.