

Little GIANT®

9EH SERIES



Features

- Handles liquids and solid waste materials up to 3/4" diameter
- Cast iron pump housing and cover with protective epoxy coating for corrosion resistance
- Oil-filled motor housing for lifetime lubrication and rapid heat dissipation
- Stainless steel screws, bolts and handle and seal assembly
- Mechanical seals (stainless steel spring, nitrile parts, carbon and ceramic faces)
- Bearings: Upper sintered sleeve bearing and lower ball bearing
- Thermal overload protection
- Manual and automatic models
- Automatic operation has 9" to 14" "On" level and 2" to 6" "Off" level range with piggyback mechanical float switch

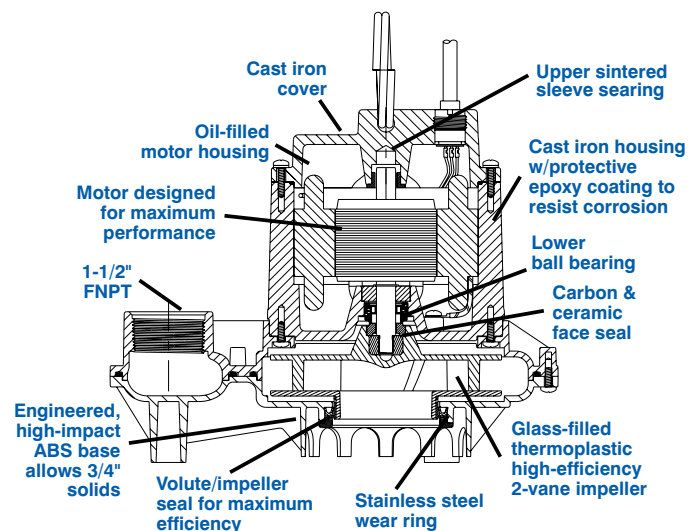

The Model 9EH Series de-watering and effluent pumps are especially designed for residential and light to medium commercial use. Pumps feature a 1-1/2" discharge with head capacity to 32' and ABS base.

9EH SERIES

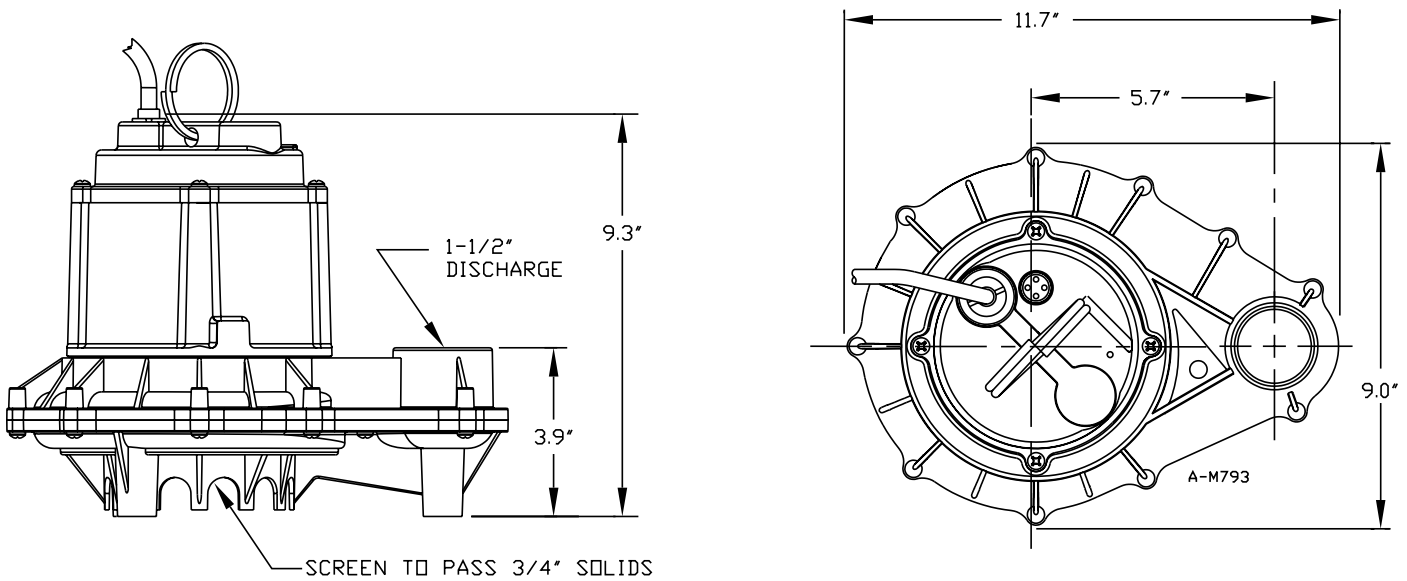

Specifications

Model No.	Item No.	Solids Size (dia.)	Listing	HP	Volts	Running Amps/Watts	Performance (GPM@Head)				Shutoff		Cord Length (ft.)	Weight (lbs.)	Dimensions (L x W x H) (in.)
							5'	10'	15'	20'	Ft.	P.S.I.			
9EH-CIM	509330	3/4"	UL/CSA	4/10	115	13.0/1000	70	64	55	41	32	13.8	20	24	9.11 x 11.64 x 8.94
9EH-CIM	509340	3/4"	UL/CSA	4/10	230	6.5/1000	70	64	55	41	32	13.8	20	24	9.11 x 11.64 x 8.94
9EH-CIA-RFS	509350	3/4"	UL/CSA	4/10	115	13.0/1000	70	64	55	41	32	13.8	20	24	9.11 x 11.64 x 8.94
9EH-CIA-RFS	509360	3/4"	UL/CSA	4/10	230	6.5/1000	70	64	55	41	32	13.8	20	24	9.11 x 11.64 x 8.94

Continuous Duty Rated — "Little Giant Wastewater pumps are rated continuous duty as long as they are run within the published ratings for these pumps."

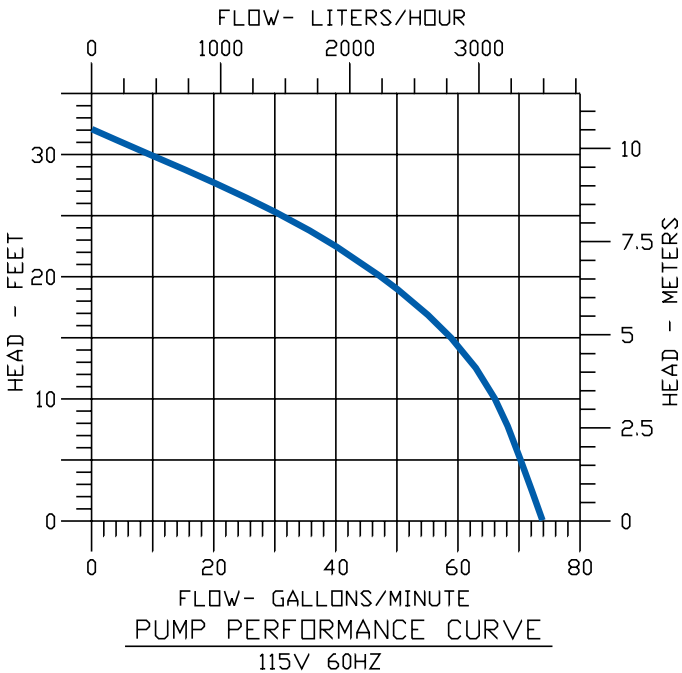

Construction

Motor Housing	Epoxy-coated cast iron
Impeller Material	Polycarbonate
Impeller Type	Closed vane
Volute	ABS
Power Cord	SJTW-A
Mechanical Shaft Seal	Nitrile with carbon and ceramic faces
Fasteners	Stainless steel
Shaft	Stainless steel
Bearings	Upper sleeve and lower ball bearings