

Location:

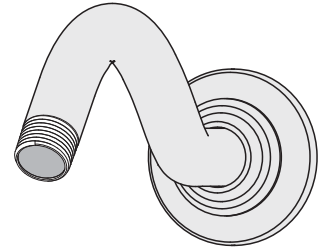

SYMMONS® Winslet™

Showerhead Arm and Flange 512SA Specification Submittal



Model Numbers

- 512SA Showerhead arm and flange

Finish Options

Append appropriate -suffix to model number.

- STN Satin nickel finish
- ORB Oil rubbed bronze finish
- Polished chrome finish (standard)

Feature Highlights

- Polished chrome finish (standard)

Standards / Certifications

ASME A112.18.1-2005/CSA B125.1-05

Warranty

- Limited Lifetime - to the original end purchaser in residential / consumer installations.
- 5 years - for commercial installations

Dimensions Winslet Showerhead Arm and Flange, 512SA

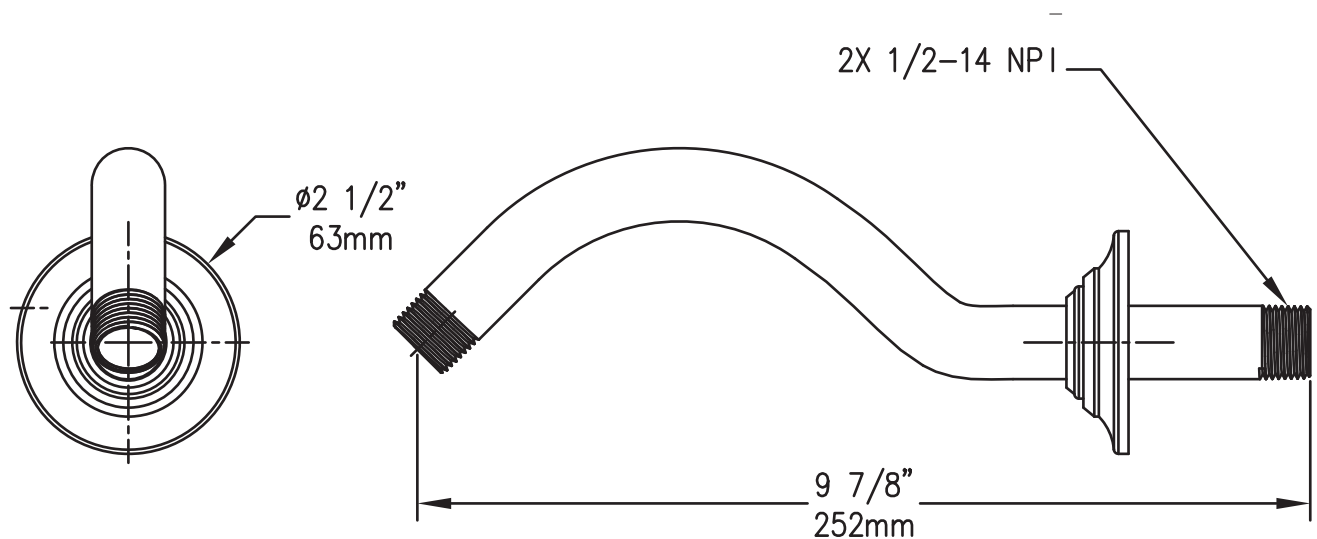

Symmons Industries, Inc. ■ 31 Brooks Drive ■ Braintree, MA 02184
(800) 796-6667, (781) 848-2250 ■ Fax (800) 961-9621, (781) 664-1300
Website: www.symmons.com ■ Email: customerservice@symmons.com

©2009 Symmons Industries, Inc. Printed in U.S.A. ■ 092809



SYMMONS®
the smart choice™