





## BACK TO BACK INSTALLATION

To simplify piping on back to back installations use one standard valve (hot on left, cold on right) and one with reverse coring (hot on right, cold on left) as shown in Figure 6 and 7. Order reverse core valve **by adding the suffix REV-X** after the plate number. (e.g. C-96-2-REV-X Temptrol® tub and shower unit with reverse coring.)

**FIGURE 6**

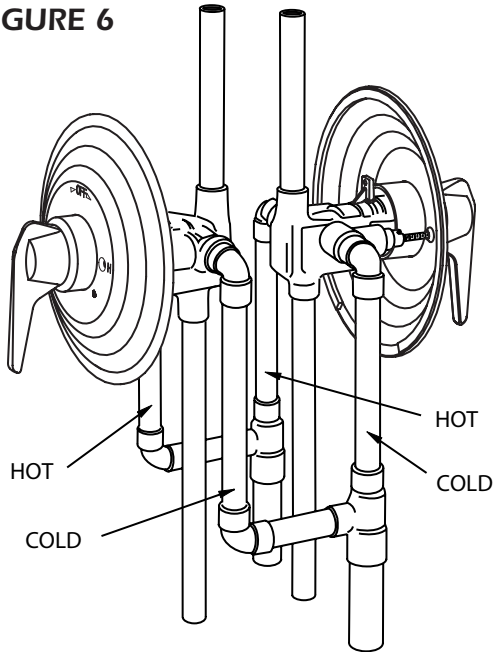

**FIGURE 7**  
**Back to Back Installation**

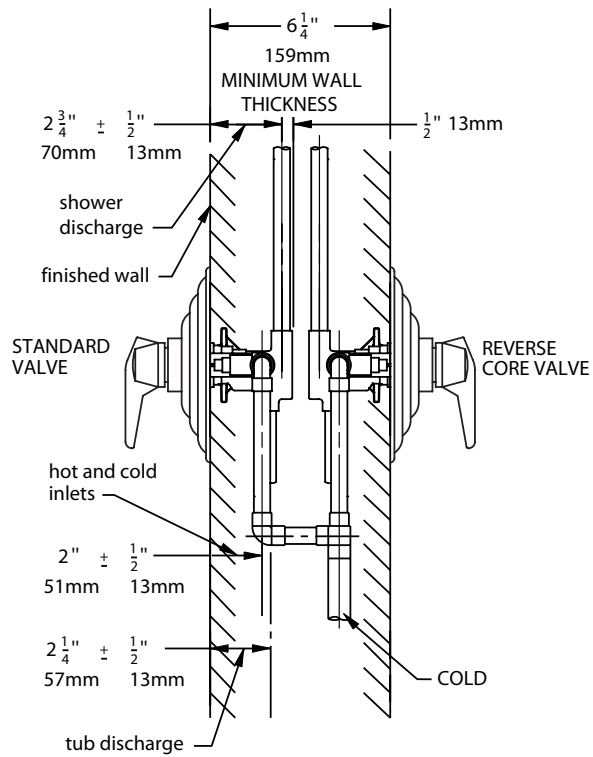

## OPERATION OF VALVE

The main handle of the Temptrol® valve is for control of temperature only. From the OFF position, the handle is turned counter-clockwise through a minimum cold position, through a warm and hot position for a maximum turn of approximately one revolution. This allows for wide range of temperature adjustments to suit the requirements of any user.

## CARE AND CLEANING

The lustrous finish on your Temptrol valve should be treated with care. It can be readily damaged by improper handling or abusive treatment. To clean the finish wipe gently with a soft damp cloth and blot dry with a soft towel. Use only a mild soap solution if required. **DO NOT USE ABRASIVE CLEANERS. USE OF POLISH, ABRASIVE CLEANERS, SOLVENTS OR ACID CLEANERS WILL DAMAGE THE FINISH AND VOID THE SYMMONS WARRANTY.**

**FIGURE 8**  
**Seat Removal Tools**

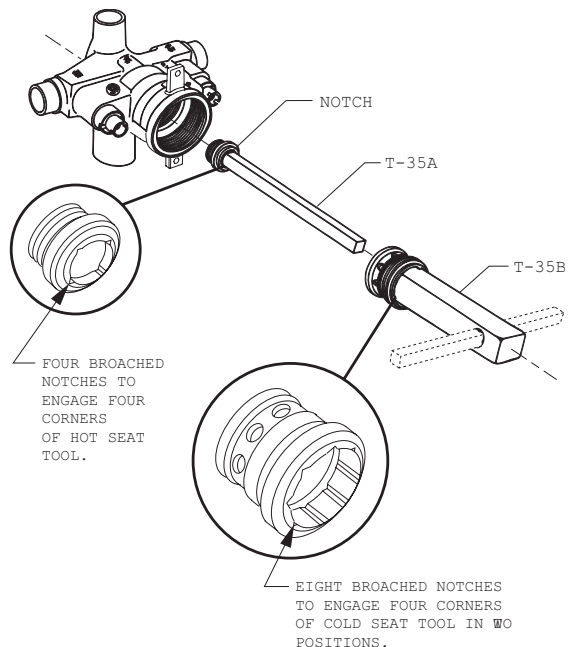

**INDIVIDUAL PARTS**

**COMPOSITE PARTS**

- DF-9B Escutcheon screws (2)
- DF-9CVP Escutcheon screws (vandal-resistant) (2)
- RC-14X Single blade lever handle
- SC-15A Set screw
- T-1 Hot renewable seat
- T-2 Cold seat O-ring
- T-3 Cold renewable seat
- T-5 Hot washer screw
- T-6 Hot washer
- T-7 Cold washer retainer
- T-8 Cold washer
- TA-10 Flow control spindle
- T-11 Cap gasket
- T-12A Cap assembly
- T-16 Packing, O-ring and washers
- T-17 Packing nut
- T-19BR Dome cover
- T-20 Lock nut
- T-34 Limit stop with O-ring
- T-35A Hot seat removal tool
- T-35B Cold seat removal tool
- T-52A Stop spindle assembly/escutcheon screw retainer
- T-55B Stop plaster shield
- T-55C Stop plaster shield removal tool
- T-169 Escutcheon
- T-177 Wall mounting flange
- T-229 Plaster shield with clip

- T-52 Stop spindle assembly/escutcheon screw retainer (T-52A)
- TA-4 Stop plaster shield (T-55B)  
Hot seat (T-1)  
Cold seat (T-3)  
Cold seat O-ring (T-2)
- TA-9 Hot washer screw (T-5)  
Hot washer (T-6)  
Cold washer retainer (T-7)  
Cold washer (T-8)  
Cap gasket (T-11)
- TA-10 Spindle assembly
- T-19/20-PL Dome cover (T-19BR)  
Lock nut (T-20)

**FIGURE 9  
Parts Breakdown**

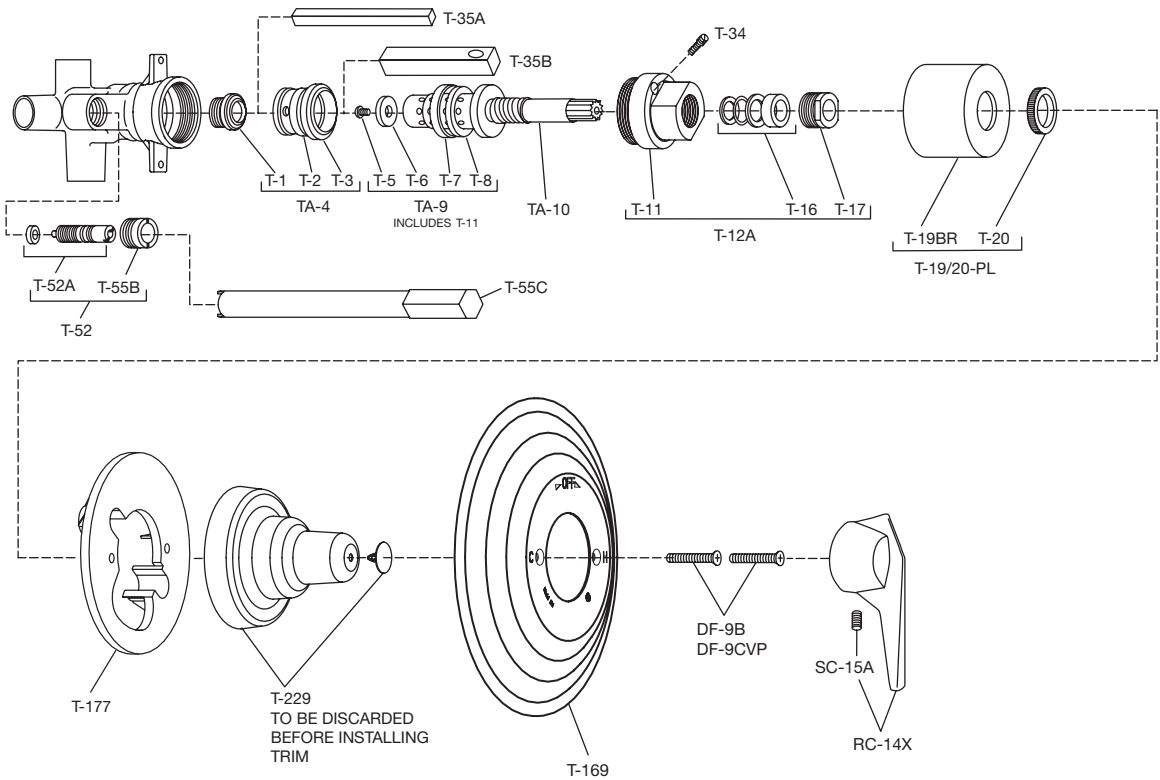

## SERVICE

1. Shut off water supply to valve or close valve integral screw driver stops by turning in clockwise direction after step 3.
2. Loosen set screw (SC-15A) and remove handle (RC-14X) (see figure 9).
3. Remove escutcheon (T-169) by removing escutcheon screws (DF-9B). Remove all remaining trim.
4. Open valve to about warm position and unscrew cap (T-12A). Warning: Failure to do this will damage cap and spindle. Spindle assembly (TA-10) will be removed with cap. Leave packing nut (T-17) in place while unscrewing cap to avoid distortion.
5. Ordinary service to eliminate dripping or not shutting off requires only the replacement of parts supplied in washer and gasket kit (TA-9). Hold spindle with handle while removing hot washer screw and cold washer retainer (remove retainer with channel lock pliers).
6. Inspect top surfaces of hot and cold seats and replace if necessary. Important: When replacing hot and cold seats, always replace both seats. Even if only one seat appears worn, both seats must be replaced. Use part No. (TA-4). After long years of service, if spindle is very loose in cold seat, replace with part no. (TA-4). Use seat removal tool [T-35(A,B)] for removal and replacement of (TA-4). If seats are difficult to remove and tool shifts damaging notches, relocate tool in second position of notches. Tighten both seats to 15 foot pounds of torque.
7. The perforated end of the (TA-10) spindle assembly houses the balancing piston which is the heart of this pressure balancing valve. The piston should be free to move back and forth and should click when the spindle assembly is shaken. If deposits block this action, tap the handle end of the spindle against a solid object to free the piston. Soaking in household vinegar will help free foreign matter. If this does not free piston, replace (TA-10) spindle assembly. **DO NOT TAMPER WITH PERFORATED CYLINDER ON THE SPINDLE ASSEMBLY OR ATTEMPT REMOVAL OF THE PISTON.**
8. Reassemble, reversing above procedure, be sure spindle assembly is drawn close to the cap before screwing cap back into valve. Warning: Failure to do this will damage cap and spindle.
9. Use only Symmons Genuine Repair Parts. Failure to do so will void all warranties AND IMPAIR PROPER OPERATION OF YOUR VALVE.

## TROUBLE SHOOTING CHART

Problem	Cause	Solution (Follow service instructions)
Valve will not pass water.	Hot and cold water not turned on.	Turn on both supplies. Valve will not operate unless both HOT and COLD water pressure is turned on.
Valve leaks when shut off.	Hot and cold washers are worn, or foreign matter (solder, chips, etc.) are between washers and seat surfaces	Replace Hot and Cold washers, inspect top surface on hot and cold seats and replace if necessary.
Temperature control handle is turned from cold to hot (or hot back to cold) and volume from spout or head is not constant.	Pressure balancing piston housed in spindle assembly is blocked from free movement by foreign matter.	With valve open half way, remove handle and tap spindle with plastic hammer. If problem not solved, remove spindle assembly completely and tap handle against solid object to free piston. Soaking in household vinegar will help free foreign matter.
Valve delivers sufficient quantity of cold, but little hot, or the reverse of this.	Same as above	Same as above
Temperature varies without moving handle.	Same as above	Same as above
Valve delivery temperature reduces gradually during use; must be turned on to hotter positions to maintain constant temperature.	Overdraw on hot water supply, i.e., running out of hot water.	Reduce maximum flow by using volume control adjustment on valve or shower head. This will allow longer period of use before overdrawing hot water supply.
Valve delivers hot water when initially opened and water turns colder when the handle is rotated in a counter-clockwise direction.	Valve is piped incorrectly, i.e., the hot supply is piped to the cold inlet to the valve and the cold supply is piped to the hot inlet of the valve.	If piping is accessible, correct piping connections to the valve. If piping is not accessible, contact factory to order a reverse seat and tool (T-108 KIT). Older installations may require replacement of the hot seat (T-1) as well
In tub/shower valves, when diverter is set in shower position a trickle of water runs from tub spout.	A design function of this valve is to allow a trickle of water from the tub spout when diverter is set for shower position. This trickle of water is necessary to ensure safe operation in that the valve will be shut off at main handle and NOT with diverter handle.	

Symmons Industries, Inc. ■ 31 Brooks Drive ■ Braintree, MA 02184  
 (800) 796-6667, (781) 848-2250 ■ Fax (800) 961-9621, (781) 843-3849  
 Website: [www.symmons.com](http://www.symmons.com) ■ Email: [customerservice@symmons.com](mailto:customerservice@symmons.com)

©2007, 2008 Symmons Industries, Inc. Printed in U.S.A. ■ ZV-459 ■ 071211



**SYMMONS®**  
the smart choice™



# SYMMONS® Temptrol®

## Commercial Series Pressure-Balancing Mixing Valve for Shower or Tub/Shower Application **INSTALLATION, OPERATION & SERVICE INSTRUCTIONS**

Symmons valves and shower heads comply to all known standards, codes and specifications: CSA B-125, ANSI A112.18.1M, ASSE 1016, EPA '92 etc.

Symmons shower heads are equipped with a 2.5 GPM (9.5 L/min) water and energy saving flow restrictor.



### **COMMERCIAL LIMITED WARRANTY**

Symmons warrants to the original purchaser that any Symmons product (excluding Symmons electronic products) when used in industrial, commercial or business use will be free of defects in material and workmanship during normal use for a period of 5 years from the date of purchase. Symmons electronic products (excluding batteries) when used in industrial, commercial or business use will be free of defects in material and workmanship during normal use for a period of 3 years from the date of purchase. At our option, we will either have you send the defective part or product prepaid to us for inspection, or we may elect to send you the replacement part or product without investigation. A replacement for any defective part will be supplied FREE OF CHARGE for installation by the purchaser. Defect or damage caused by the use of replacement parts other than Symmons Genuine Replacement Parts will void this warranty. This warranty excludes product damage due to installation error, product abuse, or product misuse whether performed by a contractor, service company or yourself.

Damage to the chrome and/or other decorative finishes on Symmons products may be a result of improper handling or abusive treatment. Finishes should only be cleaned with a soft, damp cloth or sponge. Use of polish, abrasive cleaners, solvents, or acid cleaners will damage the finish and void this warranty.

There are no other express warranties on this product and ALL WARRANTIES OF MERCHANTABILITY AND OTHER IMPLIED WARRANTIES ARE LIMITED IN ACCORDANCE WITH APPLICABLE LAW. SYMMONS INDUSTRIES, INC., EXPRESSLY DISCLAIMS CONTINGENT LIABILITY AND CONSEQUENTIAL DAMAGE OF EVERY KIND. Since some states do not allow limitations on how long an implied warranty lasts or an exclusion or limitation of incidental or consequential damages the above limitation or exclusion may not be applicable. This warranty gives specific legal rights. Other rights may vary from state to state.

To obtain warranty service, write to Symmons Industries, Inc., 31 Brooks Drive, Braintree, MA 02184-3804 or call our Customer Service Department at 1-800-SYMMONS. If writing to us, please include proof of purchase, the model number of the product with a brief description of the problem, your name, address and phone number.



**IMPORTANT:** After completion of installation step 4, follow these instructions to set the Temptrol Limit Stop Screw. This valve is equipped with a limit stop screw to be used to limit valve handle from being turned to excessively hot water discharge temperatures. To adjust, remove dome cover, open valve to maximum desired temperature and turn in limit stop screw until it seats.

**WARNING: FAILURE TO ADJUST THE LIMIT STOP SCREW PROPERLY MAY RESULT IN SERIOUS SCALDING.**

**WARNING: THIS SHOWER SYSTEM MAY NOT PROTECT THE USER FROM SCALDING WHEN THERE IS A FAILURE OF OTHER TEMPERATURE CONTROLLING DEVICES ELSEWHERE IN THE PLUMBING SYSTEM.**



**PLEASE READ ALL INSTRUCTIONS CAREFULLY BEFORE STARTING INSTALLATION. SAVE THIS MANUAL FOR FUTURE REFERENCE.**

