



# SERVICE PARTS LIST

**BULLETIN NO.**  
**54-06-3303**

|  |                |                                |                   |
|--|----------------|--------------------------------|-------------------|
| SPECIFY CATALOG NO. AND SERIAL NO. WHEN ORDERING PARTS |                | REVISED BULLETIN<br>54-06-3302 | DATE<br>Aug. 2014 |
| <b>M12™ BRUSHLESS 1/2" (13mm) DRIVER-DRILL</b>         |                |                                |                   |
| CATALOG NO.  | <b>2403-20</b> | STARTING SERIAL NO.            | <b>E27D</b>       |
|  |                | WIRING INSTRUCTION             |                   |

**EXAMPLE:**  
Component Parts (Small #)  
Are Included When Ordering  
The Assembly (Large #).

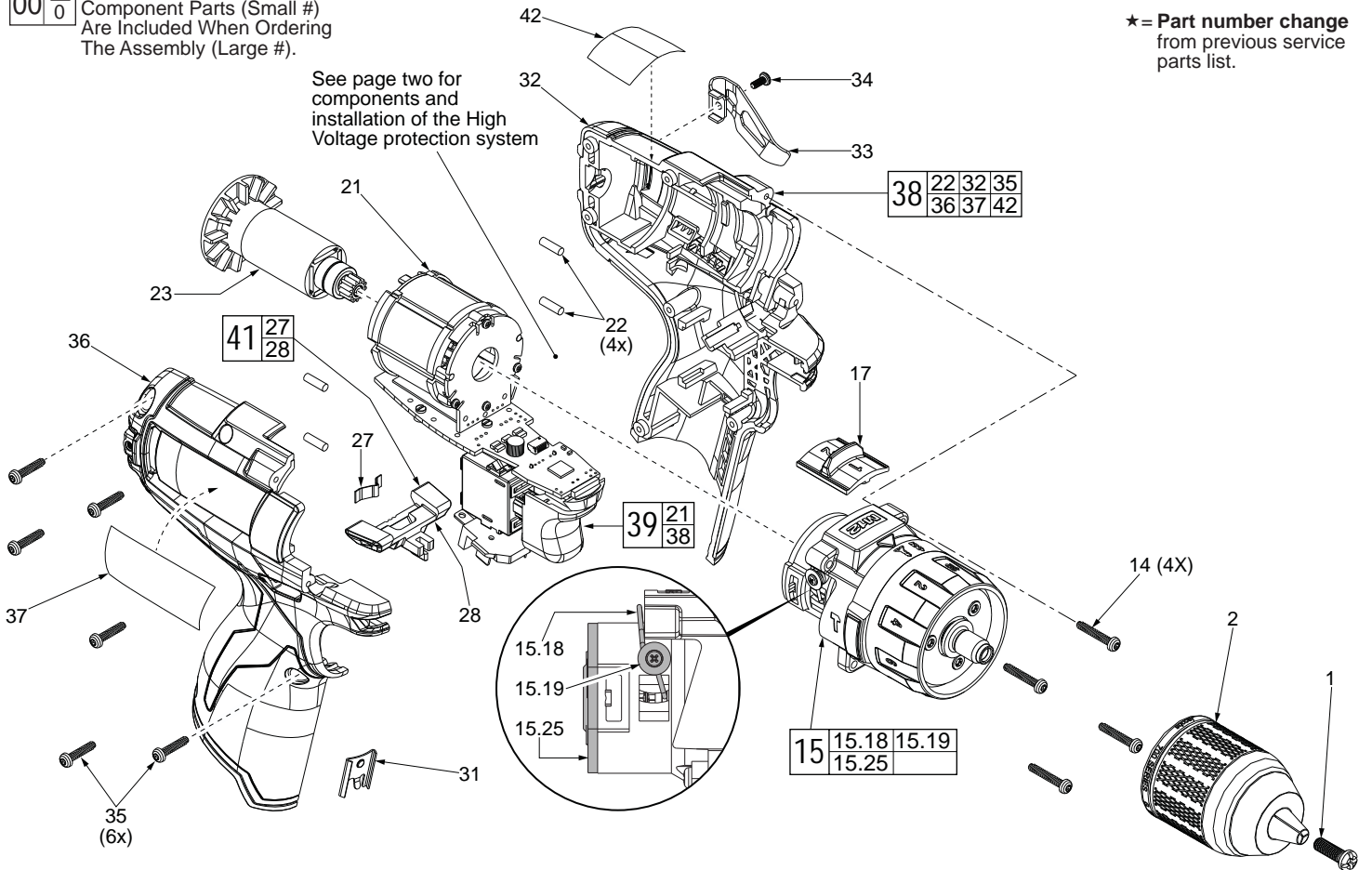

| FIG.  | PART NO.   | DESCRIPTION OF PART   | NO. REQ. |
|-------|------------|---|----------|
| 1     | 05-88-1500 | M6 x 1.0 x 27mm LH Chuck Screw                                  | (1)      |
| 2     | 42-66-0200 | 1/2" (13mm) Keyless Chuck                                       | (1)      |
| 14    | 05-88-0780 | M3 x 18mm T-10 ST Screw (Gearcase)                              | (4)      |
| 15    | 14-29-0565 | Gearcase Assembly   | (1)      |
| 15.18 | 44-10-0710 | Speed Selector Lever  | (1)      |
| 15.19 | 05-81-0542 | M2.3 x 4.5mm ST Screw   | (2)      |
| 15.25 | -----      | Motor Mounting Plate  | (1)      |
| 17    | 45-24-0325 | Speed Selector Button   | (1)      |
| 21    | -----      | Motor / Switch / PCBA Assembly                                  | (1)      |
| 22    | 45-30-0270 | Rubber Pin  | (4)      |
| 23    | 16-07-0400 | Service Rotor   | (1)      |
| 27    | 40-50-1135 | Shuttle Spring  | (1)      |
| 28    | 42-42-0610 | Forward / Reverse Shuttle                                       | (1)      |
| 31    | 42-70-0058 | Housing Connection Clip   | (1)      |
| 32    | -----      | Left Housing Halve  | (1)      |
| 33    | 42-70-0580 | Belt Clip   | (1)      |
| 34    | 05-88-1010 | M2.5 x 6mm Screw  | (1)      |
| 35    | 06-82-1080 | M3 x 14mm T-10 ST Scr (Handle Halves)                           | (6)      |
| 36    | -----      | Right Housing Halve   | (1)      |
| 37    | 12-20-2402 | Service Nameplate   | (1)      |
| 38    | 31-44-2025 | Housing Kit   | (1)      |
| ★ 39  | 14-20-1135 | Housing / Electronics Kit                                       | (1)      |
| 40    | 42-55-2100 | Blow Molded Carrying Case                                       | (1)      |
| ★ 41  | 42-42-1125 | Forward / Reverse Shuttle Kit                                   | (1)      |
| 42    | 10-20-2399 | Warning Label (French & Spanish)                                | (1)      |
| 50    | 23-94-2110 | 146mm Wire Assembly (See page two)<br>(High Voltage Protection) | (1)      |

Apply Blue Loctite® thread locking sealant or the equivalent to the threads of the chuck screw (1) before securing chuck to the gearcase spindle.



| SCREW TORQUE SPECIFICATION CHART |            |                            |                         |
|----------------------------------|------------|----------------------------|-------------------------|
| FIG.                             | PART NO.   | DESCRIPTION                | SEATING TORQUE (IN-LBS) |
| 1                                | 05-88-1500 | Chuck Screw                | 33±2.5                  |
| 15.19                            | 05-81-0542 | Speed Selector Lever Screw | 3.5±1                   |
| 14                               | 05-88-0780 | Gearcase Assembly Screw    | 7.0±2.5                 |
| 35                               | 06-82-1080 | Right Housing Halve Screw  | 7.0±2.5                 |

Model  
2402-20,  
2402-059  
shown

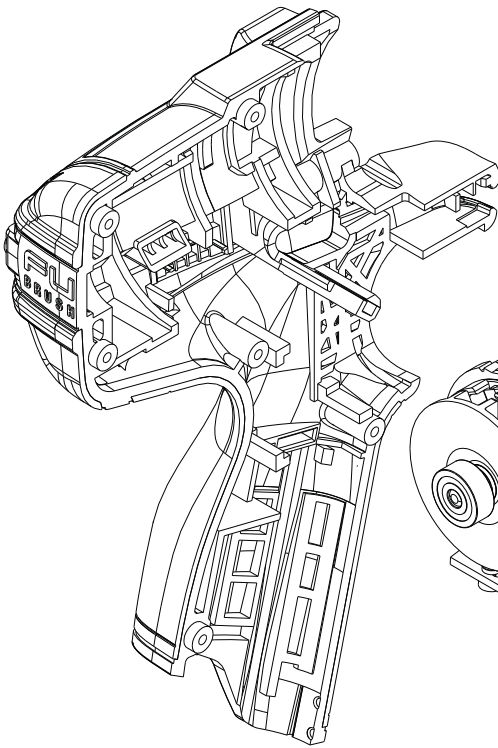

**No. 23-94-2110  
146mm Service Wire Assembly  
(High Voltage Protection)**

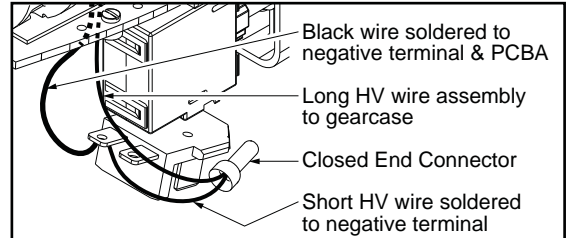
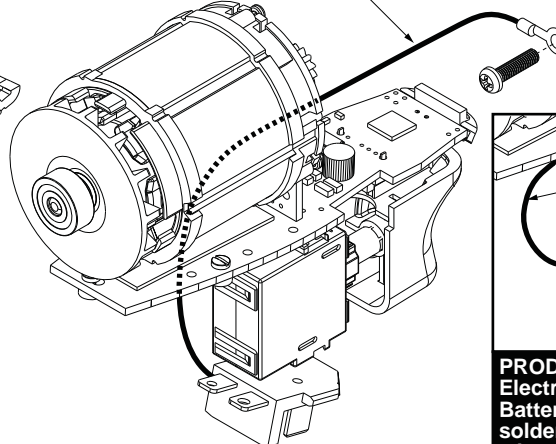
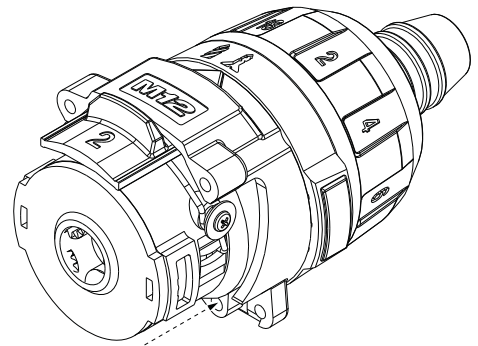

Black wire soldered to negative terminal & PCBA  
Long HV wire assembly to gearcase  
Closed End Connector  
Short HV wire soldered to negative terminal

**PRODUCTION WIRING-** For ease in production, the Electronics Assembly (Switch, Stator, PCBA and Battery Terminal Block) has a short HV wire pre-soldered to the negative terminal. During production a longer HV wire is joined to the short wire with an open end connector than grounded to the gearcase.

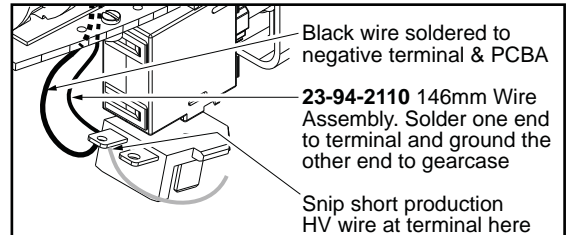
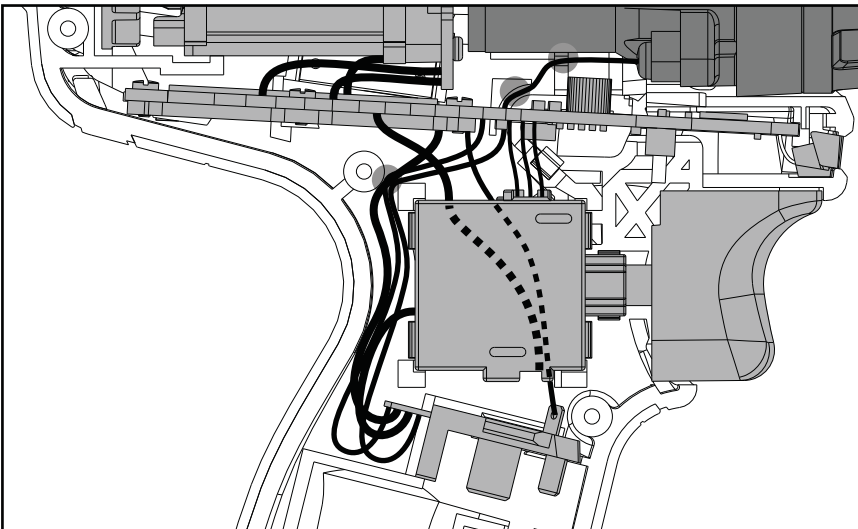

Black wire soldered to negative terminal & PCBA  
**23-94-2110** 146mm Wire Assembly. Solder one end to terminal and ground the other end to gearcase  
Snip short production HV wire at terminal here

**SERVICE WIRING-** When installing a service replacement High Voltage Wire (23-94-2110) it is recommended to snip the old HV wire system at the battery terminal. Remove and discard that short wire, the open end connector and longer wire. Follow the instructions to install new wire assembly.

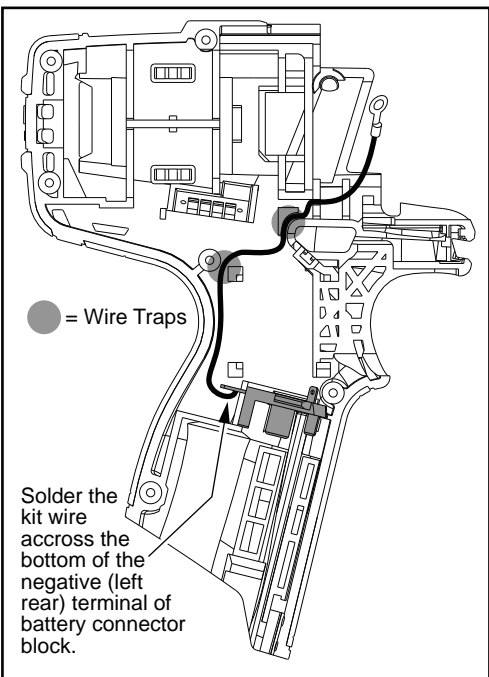

1. Remove the six handle screws, the housing connection clip and the four gearcase screws. Remove housing cover (right housing half). Carefully remove the electronics assembly and gearbox assembly from the housing support (left housing half).
2. With a small side cutter, snip the short production HV wire close to the terminal (see illustration above). Unscrew the ring terminal from the lower right position of the gearcase. Remove and discard the old HV system (short HV wire, the open end connector and longer HV wire).
3. Place the wire strand end of the 146mm High Voltage Wire (23-94-2110) across the bottom of the negative (rear left) terminal of the battery connector block and carefully solder in place (Note wire is to be positioned so wire extends to the left of the terminal, routing into the left housing half). See illustration above.
4. As an aid to routing the HV wire, carefully remove the gearcase assembly from the electronics assembly.
5. Loosely place the electronics assembly into the left housing half. Route the HV wire under the switch/battery connector block wires using the same wire trap at the upper left corner of the switch. Route HV wire behind the PCBA and into the small traps in the left housing half. Lay HV wire across the PCBA facing outward to the right.
6. Place the ring terminal of HV wire over the screw opening in the lower right position of the gearcase (with wire to the inside of the tool) and reinstall the screw to ground the system.
7. Carefully place the gearcase assembly back onto motor assembly. Secure the gearcase assembly with two of the gearcase screws into the front of the new left housing half.
8. Take time to make sure that all components are back in place. Press all wires firmly into traps. Be sure the LED, PCBA, switch assembly and battery connector block are squarely and firmly in place. Be sure the fwd./rev. shuttle functions properly and that the shuttle spring is in place.
9. Gently put the right housing half back in place and check for any interferences prior to securing with the six handle screws and two remaining gearcase screws. Insert housing clip.