

SBB Indirectly Fired Water Heater Tanks

Engineer/Architect: _____ Date: _____

Job Name/Customer: _____ Phone: _____

Location: _____ Date Required: _____

Contractor: _____ Phone: _____

Water Heater Specifications

Model # SBB _____ Item No. _____ Quantity _____ Volume _____

Specifications

	SBB 300 S	SBB 400 S	SBB 300 Plus	SBB 400 Plus	SBB 600 Plus
Item Number	221219	221222	187873	187874	187875
Contents					
Storage Capacity	82.5 gal / 305 l	110.8 gal / 411 l	80.6 gal / 305 l	108.6 gal / 411 l	162.9 gal / 617 l
Volume of heat exchanger, top	NA	NA	1.9 gal / 7.3 l	2.2 gal / 8.2 l	2.5 gal / 9.6 l
Volume of heat exchanger, bottom	2.7 gal / 10.1 l	2.9 gal / 11.3 l	2.7 gal / 10.1 l	2.9 gal / 11.3 l	3.5 gal / 13.2 l
Pressure					
Working pressure	150 psi / 10 bar	150 psi / 10 bar	150 psi / 10 bar	150 psi / 10 bar	150 psi / 10 bar
Tested to pressure	217 psi / 15 bar	217 psi / 15 bar	217 psi / 15 bar	217 psi / 15 bar	217 psi / 15 bar
Max. pressure of upper loop	NA	NA	150 psi / 10 bar	150 psi / 10 bar	150 psi / 10 bar
Temperature					
Max. temperature of lower loop	266 °F / 130 °C	266 °F / 130 °C	266 °F / 130 °C	266 °F / 130 °C	266 °F / 130 °C
Max temperature of upper loop	NA	NA	266 °F / 130 °C	266 °F / 130 °C	266 °F / 130 °C
Heat exchanger					
Surface area heat exchanger top	NA	NA	1,705 sq. in / 1.1 m ²	2,015 sq. in / 1.3 m ²	2,945 sq. in / 1.9 m ²
Surface area heat exchanger bottom	2,325 sq. in / 1.5 m ²	2,635 sq. in / 1.7 m ²	2,325 sq. in / 1.5 m ²	2,635 sq. in / 1.7 m ²	3,875 sq. in / 2.5 m ²
Output rating heat exchanger top 50 °F Inlet, 140 °F Outlet	NA	NA	83,250 BTU/hr / 24 kW	96,000 BTU/hr / 28 kW	136,500 BTU/hr / 40 kW
Output rating heat exchanger bottom 50 °F Inlet, 140 °F Outlet	112,500 BTU/hr / 33 kW	123,000 BTU/hr / 36 kW	112,500 BTU/hr / 33 kW	123,000 BTU/hr / 36 kW	181,500 BTU/hr / 53 kW
Recovery rate (maximum input)	125 gal/hr / 473 l/hr	102 gal/hr / 386 l/hr	224 gal/hr / 848 l/hr	186 gal/hr / 704 l/hr	180 gal/hr / 681 l/hr
Weights					
Tank weight empty	292 lb / 133 kg	371 lb / 169 kg	339 lb / 154 kg	412 lb / 187 kg	544 lb / 247 kg
Tank weight full	988 lb / 448 kg	1304 lb / 591 kg	1051 lb / 477 kg	1362 lb / 618 kg	1955 lb / 887 kg
Other					
Standby losses in 24 hours	6500 BTU / 1.9 kWh	7500 BTU / 2.2 kWh	6500 BTU / 1.9 kWh	7500 BTU / 2.2 kWh	10000 BTU / 2.9 kWh
Cold/hot water connection	1" copper pipe via adapter				
Dimensions					
Height with insulation	66 3/32" / 1,679 mm	72 11/16" / 1,848 mm	66 3/32" / 1,679 mm	72 11/16" / 1,848 mm	68 5/16" / 1,735 mm
Width with insulation	27 9/16" / 700 mm	29 1/2" / 750 mm	27 9/16" / 700 mm	29 1/2" / 750 mm	36 1/4" / 920 mm *
Width of insulation	3" / 75 mm	3" / 75 mm	3" / 75 mm	3" / 75 mm	3 11/32" / 85 mm *

* Insulation is partially removable to reduce width to 31.5" for clearance purposes



SBB tanks are ETL certified in US and Canada to IAS U.S. Requirements for Indirect Fired Water Heaters For Use With External Heat Source. No 1-91, Dated June 6, 1992



Tested and Certified by Water Quality Association against NSF/ANSI 372 for lead free compliance.

Dimensions

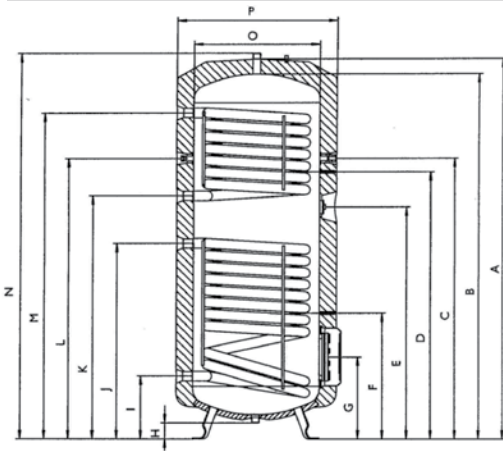

Type		SBB 300 Plus	SBB 400 Plus	SBB 600 Plus
A	Height of unit w/insulation	in/mm 66.1/1679	72.7/1848	68.3/1735
B	Height of unit without insulation	in/mm 63.3/1609	70.1/1781	65.7/1670
C	Height of well for temp. sensor	in/mm 46.4/1179	48.7/1238	46.9/1192
D	Height thermometer	in/mm 41.1/1045	43.0/1093	41.5/1055
E	Height spare port	in/mm 40.3/1025	42.4/1078	40.9/1040
F	Height of well for temp. sensor	in/mm 21.9/557	22.0/560	23.4/595
G	Height inspection flange	in/mm 14.4/365	14.4/367	15.9/405
H	Height cold water feed	in/mm 2.9/73	2.6/65	2.0/50
I	Height solar cold feed	in/mm 11.0/280	11.1/282	10.9/277
J	Height solar hot return	in/mm 34.0/865	34.1/867	33.9/862
K	Height heater hot boiler return	in/mm 38.4/975	44.5/1130	42.9/1089
L	Height circulation port	in/mm 52.7/1339	63.0/1600	57.2/1453
M	Height cold boiler feed	in/mm 52.7/1339	63.0/1600	57.2/1453
N	Overall height	in/mm 67.08/1704	73.74/1873	69.29/1760
O	Width without thermal insulation	in/mm 21.65/550	23.62/600	29.52/750
P	Width with thermal insulation	in/mm 27.55/700	29.52/750	36.22/920



Left to right:
SBB 300
SBB 400
SBB 600 Plus

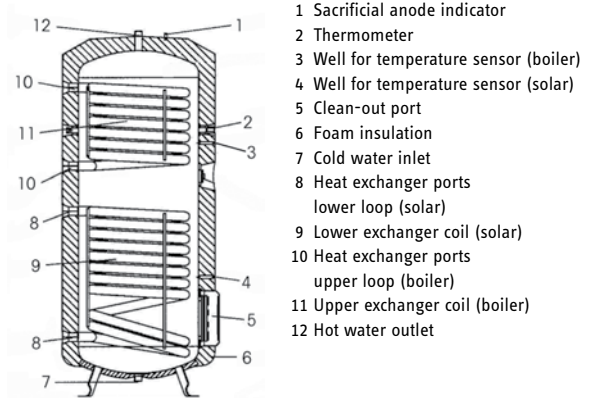

- 1 Sacrificial anode indicator
- 2 Thermometer
- 3 Well for temperature sensor (boiler)
- 4 Well for temperature sensor (solar)
- 5 Clean-out port
- 6 Foam insulation
- 7 Cold water inlet
- 8 Heat exchanger ports lower loop (solar)
- 9 Lower exchanger coil (solar)
- 10 Heat exchanger ports upper loop (boiler)
- 11 Upper exchanger coil (boiler)
- 12 Hot water outlet

Warranty

Subject to the terms and conditions set forth in this limited lifetime warranty, Stiebel Eltron, Inc. (the "Manufacturer") hereby warrants to the original purchaser (the "Owner") that each storage tank (the "Tank") shall be free from defects in the Manufacturer's materials or workmanship for a period of:

1. (Lifetime) for the tank and heat exchanger from the date of purchase;
2. (8 Years) for part(s) not referenced above from the date of purchase;
3. (Excluded) sacrificial anode

As Owner's sole and exclusive remedy for the above warranty, Manufacturer shall, at the Manufacturer's discretion, either factory repair or replace the defective Tank with a replacement unit or part(s) with comparable operating features. Manufacturer's maximum liability under all circumstances shall be limited to the Owner's purchase price for the Tank.

This limited warranty shall be the exclusive warranty made by the Manufacturer and is made in lieu of all other warranties, express or implied, whether written or oral, including, but not limited to warranties of merchantability and fitness for a particular purpose. Manufacturer shall not be liable for incidental, consequential or contingent damages or expenses arising directly or indirectly from any defect in the Tank or the use of the Tank. Manufacturer shall not be liable for any water damage or other damage to property of Owner arising, directly

or indirectly, from any defect in the Tank or the use of the Tank. Manufacturer alone is authorized to make all warranties on Manufacturer's behalf and no statement, warranty or guarantee made by any other party shall be binding on Manufacturer.

Manufacturer shall not be liable for any damage whatsoever relating to or caused by:

1. any misuse or neglect of the Tank, any accident to the Tank, any alteration of the Tank, or any other unintended use;
2. acts of God and circumstances over which Manufacturer has no control;
3. installation of the Tank other than as directed by Manufacturer and other than in accordance with applicable building codes;
4. improper installation and/or improper materials used by any installer and not relating to defects in parts or workmanship of Manufacturer;
5. failure to maintain the Tank or to operate the Tank in accordance with the Manufacturer's specifications;
6. failed components not originally installed by the Manufacturer as a part of the unit at the time of sale;
7. exposure to freezing conditions;
8. exposure to harmful chemicals, contaminated water, corrosive fluids or atmosphere, liquids harmful to steel tubing including improperly applied or maintained heat transfer fluids.

Warranty (Cont.)

9. utilizing the tank as an open loop heat exchanger, e.g., do not use in drainback systems or continually pass fresh potable water through the units internal heat exchanger.
10. installing the Tank in a closed system without a properly sized and installed thermal expansion tank;
11. operating the Tank without the factory installed sacrificial anode;
12. operating the Tank under fluctuating or excessive water pressure or in the event the Tank is supplied with non-potable water for any duration;
13. operating the Tank when it is empty or partially full of potable water;
14. Installing and operating the Tank outdoors;
15. operating the Tank at temperatures higher than recommended by Manufacturer;
16. (SB E models) replacing the electric heating element with a unit not manufactured by Stiebel Eltron or greater in power than the originally installed element;
17. (SB E models) connecting the Tank to improper voltage or service;

Should owner wish to return the Tank to manufacturer for repair or replacement under this warranty, Owner must first secure written authorization from Manufacturer. Owner shall demonstrate proof of purchase, including a purchase date, and shall be responsible for all removal and transportation costs. If Owner cannot demonstrate a purchase date this warranty shall be limited to the period beginning from the date of manufacture stamped on the Tank. Manufacturer reserves the right to deny warranty coverage upon Manufacturer's examination of the Tank. This warranty is restricted to the Owner and cannot be assigned.

Some States and Provinces do not allow the exclusion or limitation of certain warranties. In such cases, the limitations set forth herein may not apply to the Owner. In such cases this warranty shall be limited to the shortest period and lowest damage amounts allowed by law. This warranty gives you specific legal rights and you may also have other rights which vary from State to State or Province to Province.

Owner shall be responsible for all labor and other charges incurred in the removal or repair of the Tank in the field. Please also note that the Tank must be installed in such a manner that if any leak does occur, the flow of water from any leak will not damage the area in which it is installed.