



1 1/4 H.P. heavy duty disposer is designed for continuous operation in restaurants, hotels, hospitals and cafeterias. Food waste including steak bones is quickly and efficiently removed with this labor-saving, self-cleaning, environmentally sound disposer.

# 1 1/4 H.P. MODEL SS-125

## SPECIFICATIONS

- GRIND CHAMBER -** Corrosion Resistant Stainless Steel
- MOUNTING -** 3/4" rubber mounting above grinding chamber isolates sound and eliminates vibration. Mounting is enclosed in chrome plated covers for sanitation and appearance.
- MOTOR -** 1 1/4 HP Induction Motor, 1725 RPM's, totally enclosed to provide protection against outside moisture. Controlled power air flow cools motor for efficiency and longer life. Built-in thermal overload protection.
- CUTTING ELEMENTS -** Stationary and rotating shredding elements made from cast nickel chrome alloy for long life and corrosion resistance, designed for reverse action grinding.
- MAIN BEARINGS -** Double-tapered Timken roller bearings provide a shock absorbing cushion.
- MOTOR SEALS -** Triple lip seal protects motor from water damage. Secondary spring-loaded oil seal provides double protection against water and loss of grease.
- FINISH -** All Stainless Steel and Chrome plated. Paint-free for lasting sanitation.
- WARRANTY -** 1 year full warranty from date of installation.



### BASE DISPOSER/ELECTRICAL REQUIREMENTS

- 115 volts, 1 phase, 10.6 amps
- 208 volts, 3 phase, 3.5 amps
- 208 volts, 1 phase, 4.5 amps
- 230 volts, 3 phase, 4.0 amps
- 230 volts, 1 phase, 5.3 amps
- 460 volts, 3 phase, 2.0 amps

NOTE: All amp ratings denote the amp draw during a grind load.

### DISPOSER MOUNTING ASSEMBLIES

- #5 Sink Flange Mounting Assemblies for 3 1/2" - 4" sink opening  
\*Support legs are recommended for this unit when using #5 mounting

- #6 Collar Adapter for welding into trough, provides 6 5/8" opening, includes splash baffle

- #7 Collar Adapter for welding into sink, provides 6 5/8" opening, includes splash baffle and stopper

- Type A Sink Bowl Assembly\*

- Type B Sink Bowl Assembly\*

- Type C Sink Bowl Assembly\*

\*If using Type A, B, or C, you must specify either a 12", 15" or 18" sink bowl.

### Select Sink Bowl Assembly Size

- 12" with one adjustable water nozzle
- 15" with one adjustable water nozzle
- 18" with two adjustable water nozzles

### ELECTRICAL CONTROLS

- Manual Switch (Single Direction)

- Manual Reverse Switch (Dual Direction)

- Low Voltage Magnetic Starter (Single Direction)

- CC-202 Control Center (Auto-Reversing)

- CC-101 Control Center (Auto-Reversing)

- AS-101 Control Center "Aqua Saver" (Auto-Reversing)

### WATER CONTROLS

- Solenoid Valve
- Syphon Breaker
- Flow Control Valve

### Recommended Water Usage

**Standard**  
5 GPM

**Optional**  
3 GPM

For additional information, see Commercial Product Information Binder.

### A COMMERCIAL DISPOSER PACKAGE INCLUDES:

1 Mounting/Bowl Assembly, 1 Electrical Control, 1 Syphon Breaker, 1 Solenoid Valve, and 1 Flow Control Valve. The standard Flow Control Valve will be sent with the unit unless the optional valve is specified.



4700 21st STREET  
RACINE, WI 53406-5093  
TEL: 800-558-5712 x8025, 8030, 8083  
FAX: 262 554-3620  
[www.insinkerator.com](http://www.insinkerator.com)

The Emerson logo is a trademark and a service mark of Emerson Electric Co.



# RECOMMENDED INSTALLATION

# MODEL SS-125

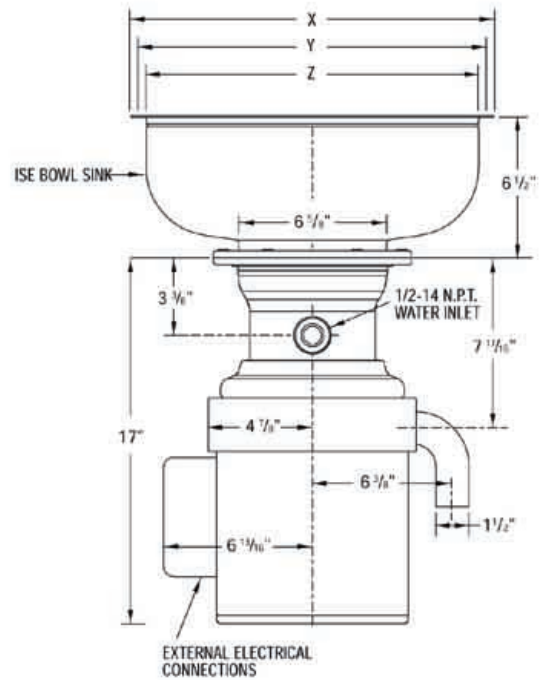
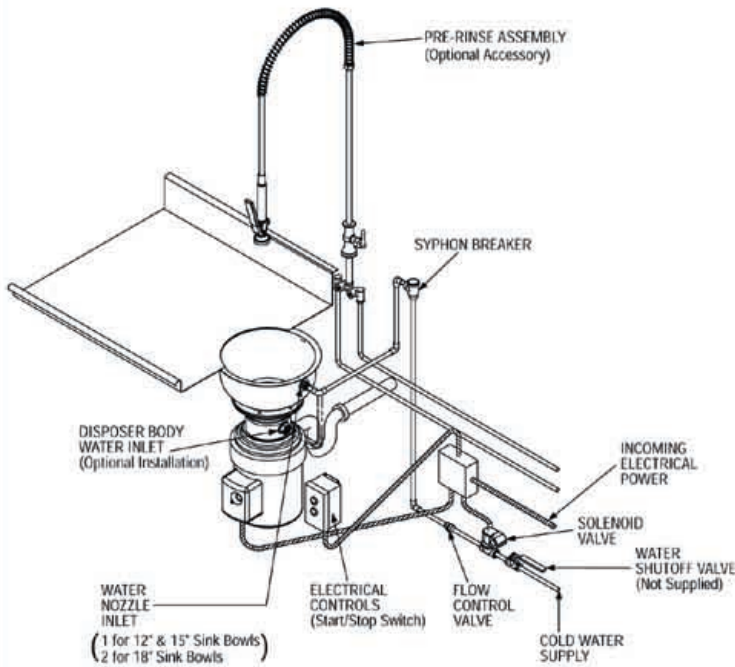

**IMPORTANT:** Use dimension chart below for adaptor height in place of ISE bowl sink height when mounting directly to a sink.

## DIMENSIONS

- X — Flange O.D.
- Y — Diameter of Work Table Hole
- Z — Flange I.D.

BOWL SINKS	X	Y	Z	HEIGHT
12"	13 1/2"	12 1/4"	12"	6 1/2"
15"	16 1/2"	15 1/4"	15"	6 1/2"
18"	19 1/2"	18 1/4"	18"	6 1/2"
ADAPTORS	X	Y	Z	HEIGHT
No.5	Fits Standard Sink Opening — 3 1/2" — 4"			2 3/4"
No.6	7 13/16"	6 7/8"	6 5/8"	1 3/16"
No.7	9 1/8"	7 7/8"	7 5/8"	2 1/16"

## 1 1/4 H.P. COMMERCIAL DISPOSER

### SAMPLE SPECIFICATION

ITEM NO. \_\_\_\_\_ DISPOSER

Quantity: One required (1)

Manufacturer: IN-SINK-ERATOR

Commercial Division, Racine, WI

Model: SS-125-5/CC202

Electrical Requirements: \_\_\_\_\_ volts/  
\_\_\_\_\_ phase

Install in \_\_\_\_\_, Item \_\_\_\_\_.



## NOTE:

- Adaptors are available upon request for all competitor sink bowls or cones.
- Please have sink bowl/cone type with the necessary dimensions when ordering adaptors.