

**PA-300C**

**PA-300SS**

**PA-300ORB**



## **Single Handle Bar Faucet**

# **Product Spec Sheet**



### **FEATURES & BENEFITS**

- This Product Contains Less Than 0.25% Weighted Average Lead Content On Wetted Surfaces
- Metal Lever Handle
- Ceramic Cartridge
- Max Flow Rate 2.2 GPM (8.5 LPM) at 60 PSI (ASME.A112.18.1)

PA-300C  
Chrome Finish

PA-300SS  
Stainless Steel Finish

PA-300ORB  
Oil Rubbed Bronze Finish

### **APPROVALS:**

**Meets or Exceeds The Following:**

- \* ANSI/ASME A112.18.1
- \* ANSI/NSF 61 – Sec. 9
- \* IAPMO/UPC
- \* CA AB1953



**CALIFORNIA:**  
**TEXAS:**  
**NEW YORK:**

**TEL: 866-532-8306**  
**TEL: 800-935-5456**  
**TEL: 800-431-2082**

**FAX: 866-532-8307**  
**FAX: 800-683-4247**  
**FAX: 800-640-2252**

Visit Our Web Site : [www.matco-norca.com](http://www.matco-norca.com)

**PA-300C**

**PA-300SS**

**PA-3000RB**



# Single Handle Bar Faucet

No.	Name	Material
1	Handle Cap	Brass
2	Metal Handle Assembly	Zinc Alloy
3	Trim Cap	Plastic
4	Locking Nut	Brass
5	Ceramic Disc Cartridge	Ceramic & Brass
6	Aerator	Plastic & Brass
7	Spout Assembly	Brass
8	Spout Trim Ring	Brass
9	Mounting Hardware	Stainless Steel
10	Supply Hose	Stainless Steel

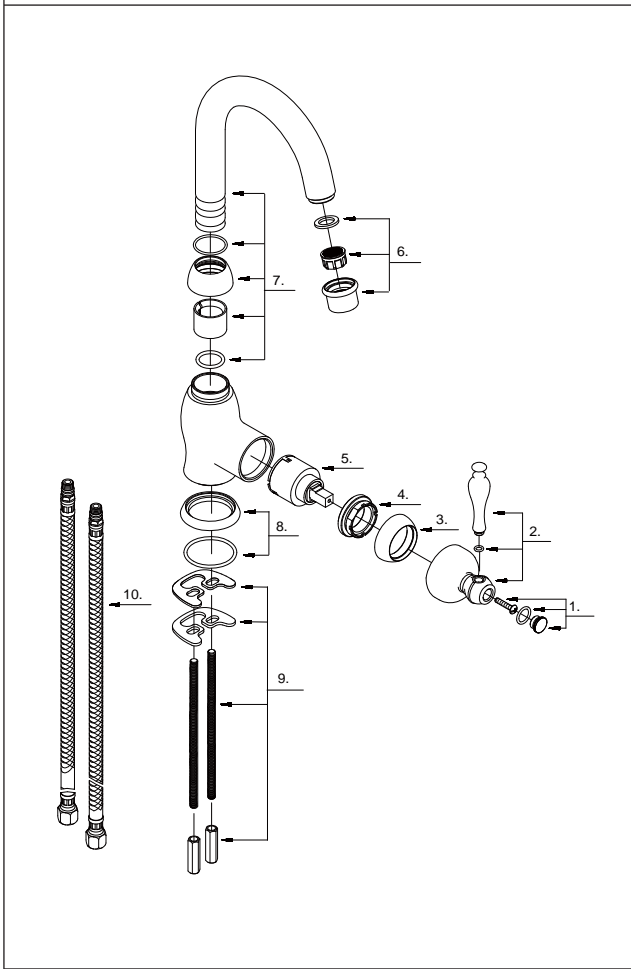

# Product Spec Sheet

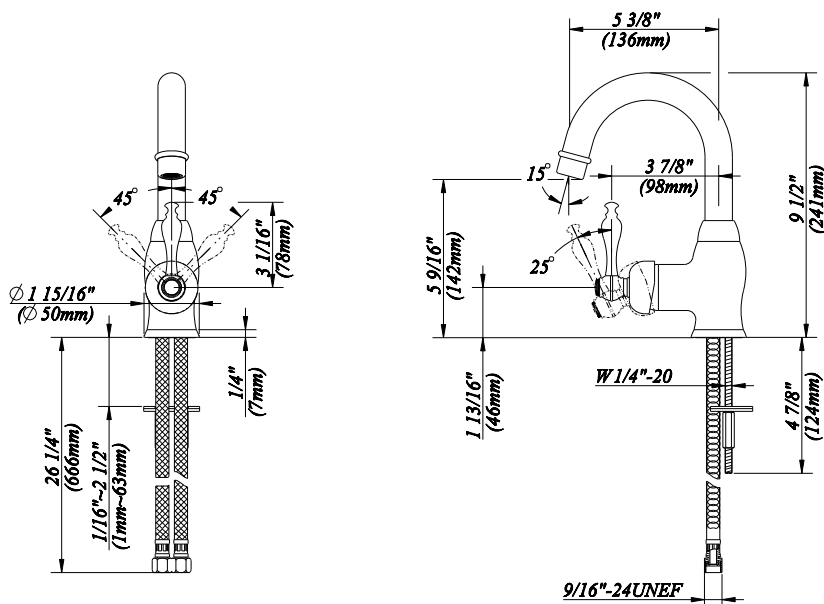

### APPROVALS:

Meets or Exceeds The Following:

- \* ANSI/ASME A112.18.1
- \* ANSI/NSF 61 – Sec. 9
- \* IAPMO/UPC
- \* CA AB1953

CALIFORNIA: TEL: 866-532-8306 FAX: 866-532-8307  
 TEXAS: TEL: 800-935-5456 FAX: 800-683-4247  
 NEW YORK: TEL: 800-431-2082 FAX: 800-640-2252

Visit Our Web Site : [www.matco-norca.com](http://www.matco-norca.com)