

**AC POWERED FLUSH VALVE**

MODEL 8310AC16, 8312AC10 SERIES

**FLUXÓMETROS ALIMENTADO (CA)**

MODELO 8310AC16, 8312AC10 SERIES

**ROBINETS DE CHASSE (AC)**

MODÈLES 8310AC16, 8312AC10 SERIE

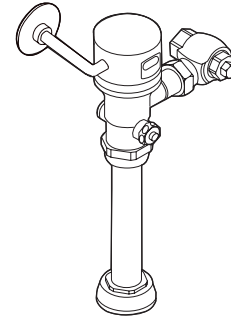
**English**
**Español**
**Français**
**HELP LINE**
 **Please do not return this product to the store.**

If you need installation assistance, replacement parts or have questions regarding our warranty, please call our Product Consultants at:  
**U.S.: 1-800-289-6636**  
 Monday - Friday 8:00 a.m. to 8:00 p.m. EST  
 Saturday 8:00 a.m. to 6:30 p.m. EST  
 Or e-mail us at:  
[moenwebmail@moen.com](mailto:moenwebmail@moen.com)  
 Be sure to visit our website at  
[www.moen.com](http://www.moen.com)  
**Canada 1-800-465-6130**  
 Monday - Friday 7:30 a.m. to 5:00 p.m. EST  
 Or e-mail us at: [cantsd@moen.com](mailto:cantsd@moen.com)  
 Be sure to visit our website at  
[www.moen.com](http://www.moen.com)

When ordering parts, specify finishes.

 **CAUTION:** Always turn water supply OFF before removing existing faucet or disassembling the valve. Open faucet handle to relieve water pressure and ensure that complete water shut-off has been accomplished.

**CARE INSTRUCTIONS**

To preserve the finish on the metallic parts of your Moen product, apply non-abrasive wax, such as car wax. Any cleaners should be rinsed off immediately. Mild abrasives are acceptable on Platinum and LifeShine® finishes.

**LÍNEA DE AYUDA**
 **Por favor no devuelva este producto a la tienda.**

Si necesita ayuda para la instalación, piezas de repuesto o tiene alguna pregunta relacionada con nuestra garantía, por favor llame a nuestros asesores de producto al:  
**En la República Mexicana: 01-800-718-4345**  
 Lunes a viernes de 8:00 a.m. a 6:00 p.m. hora Central  
 O envíenos un correo electrónico a:  
[tcoronado@moen.com.mx](mailto:tcoronado@moen.com.mx)  
 Visite nuestra página de Internet:  
[www.moen.com.mx](http://www.moen.com.mx)

Quando ordene piezas, por favor especifique los acabados.

 **PRECAUCIÓN.** Siempre CIERRE la toma de agua antes de quitar la llave existente o desmontar la válvula.

**INSTRUCCIONES DE CUIDADO**

Para conservar el acabado que cubre las partes metálicas de su producto mezcladora Moen, aplique cera que no sea abrasiva, como una cera para autos. Si usa algún tipo de limpiador, deberá enjuagarlo inmediatamente. Los abrasivos suaves son aceptables en acabados Platinum y LifeShine®.

**SERVICE À LA CLIENTÈLE**
 **Prière de ne pas retourner ce produit au magasin.**

Pour obtenir de l'aide pour l'installation, le remplacement de pièces ou pour toute question concernant notre garantie, appeler un de nos spécialistes des produits :  
**Toronto : (905) 829-3400**  
**Ailleurs au Canada: 1 800 465-6130**  
 7 h 30 à 17 h HNE  
 Ou par courriel à l'adresse :  
[cantsd@moen.com](mailto:cantsd@moen.com)  
 Visitez notre site web à l'adresse  
[www.moen.com](http://www.moen.com)

Spécifier le ou les finis dans la commande.

 **ATTENTION:** Toujours couper l'alimentation en eau avant d'enlever ou de démonter le robinet.

**DIRECTIVES D'ENTRETIEN**

Pour préserver le fini des pièces métalliques du produit Moen, appliquer une cire non abrasive comme une cire à voiture. Rincer immédiatement le robinet après l'avoir nettoyé avec un agent nettoyant. Les finis Platinum et LifeShine® peuvent être nettoyés à l'aide de produits abrasifs doux.

**HELPFUL TOOLS**

For safety and ease of faucet replacement, Moen recommends the use of these helpful tools.



Thread seal tape  
Cinta de rocas  
Ruban pour joints filetés

**HERRAMIENTAS ÚTILES**

Para que el cambio de la llave sea fácil y seguro, Moen le recomienda usar estas útiles herramientas.

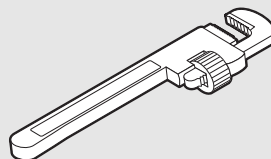

**OUTILS UTILES**

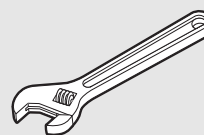
Par mesure de sécurité et pour faciliter l'installation, Moen suggère l'utilisation des outils suivants.

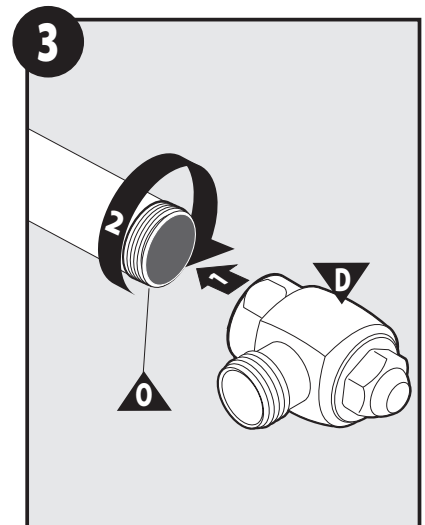
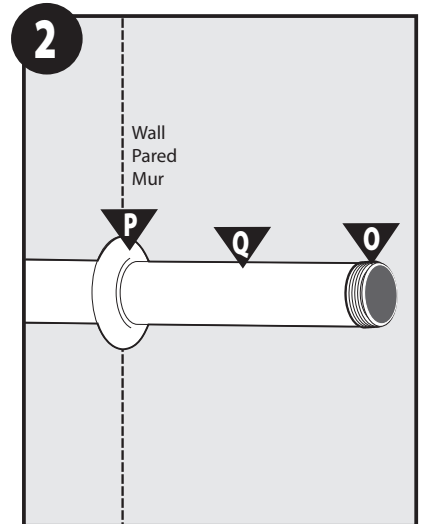
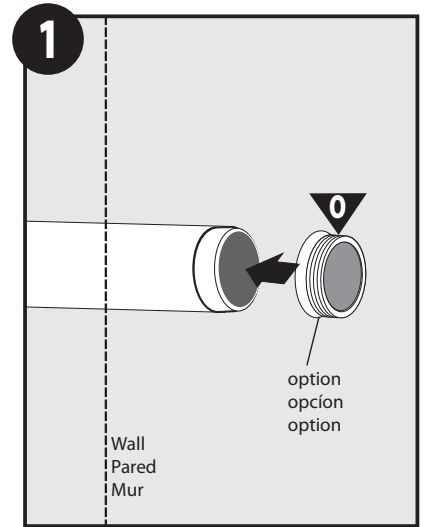
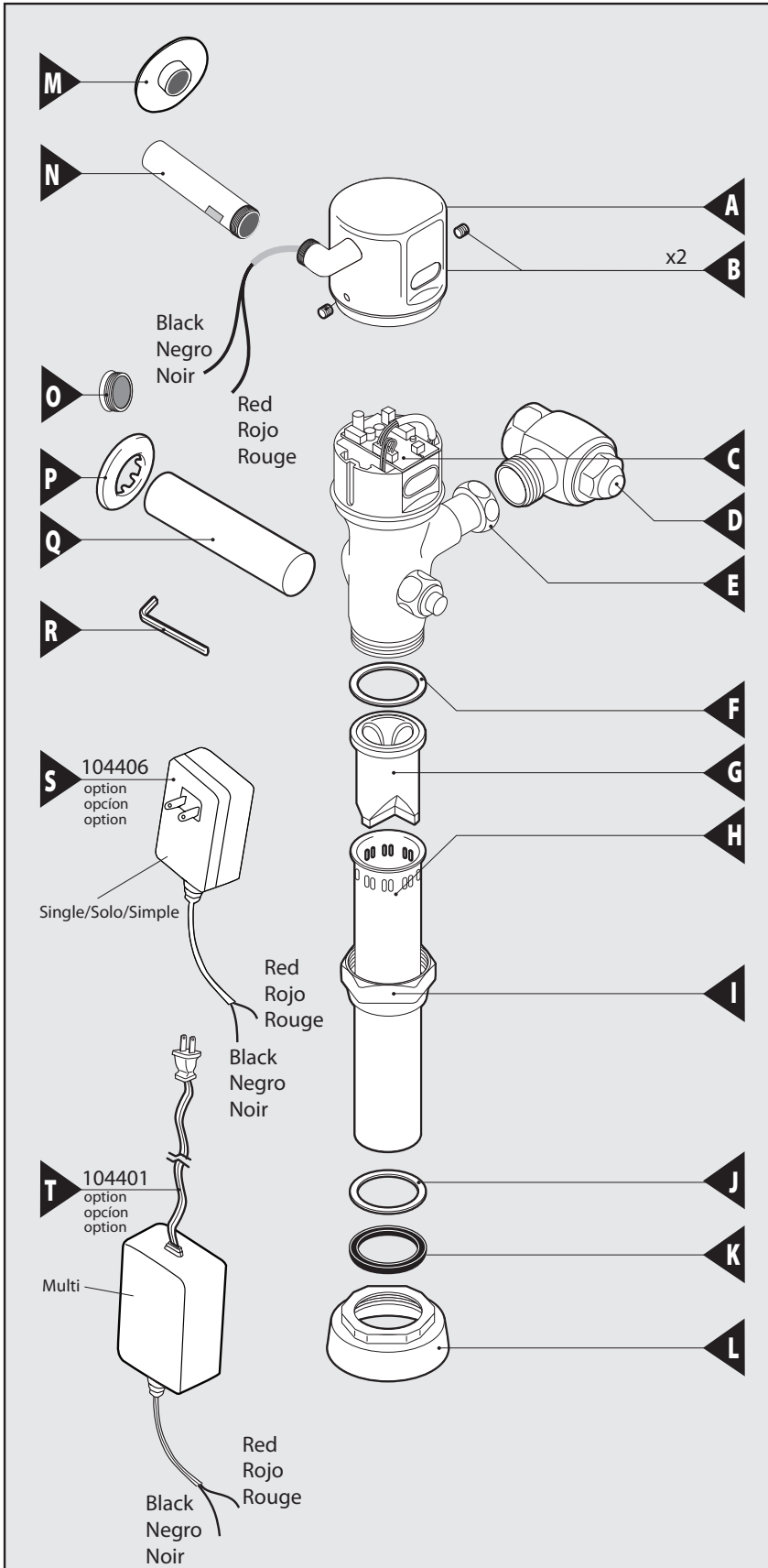

Solder Kit  
Nécessaire à Souder  
Equipo de Soldar

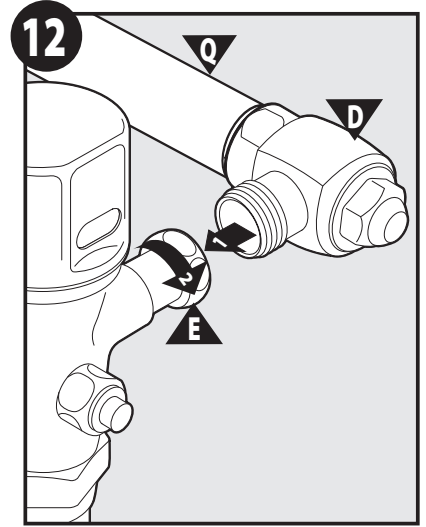
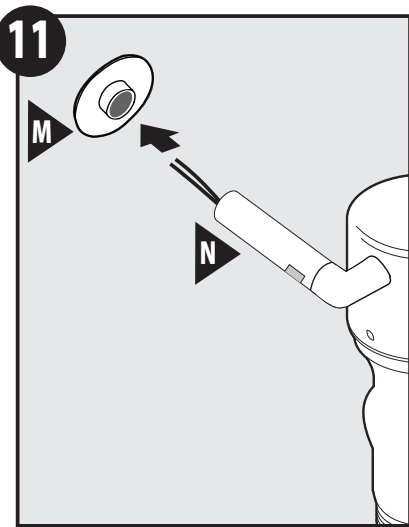
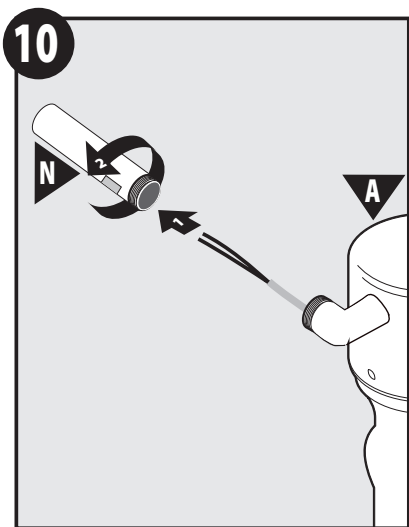
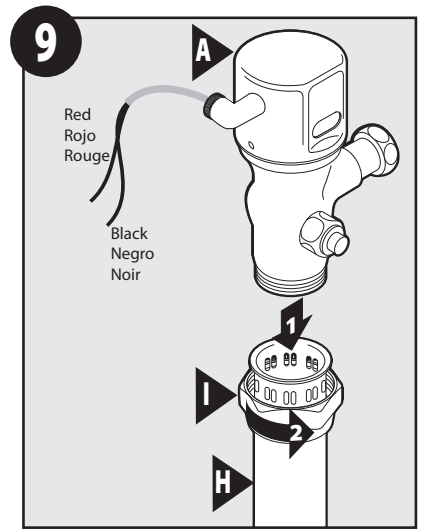
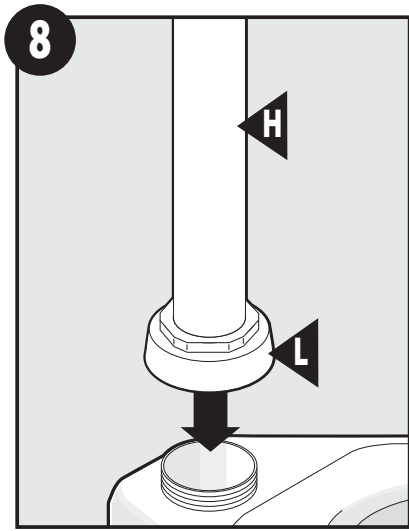
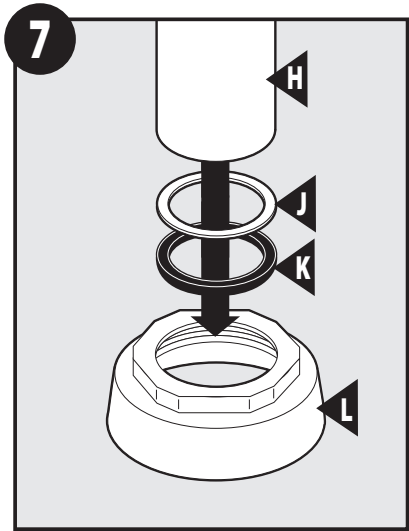
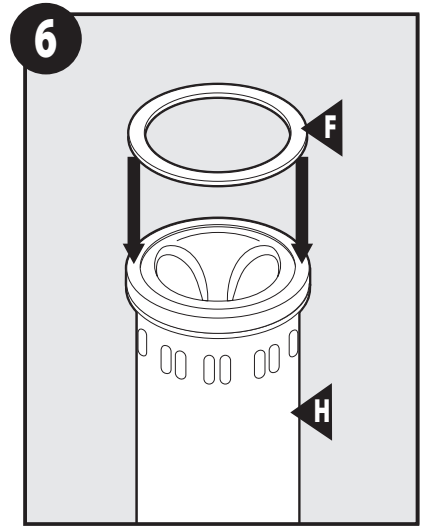
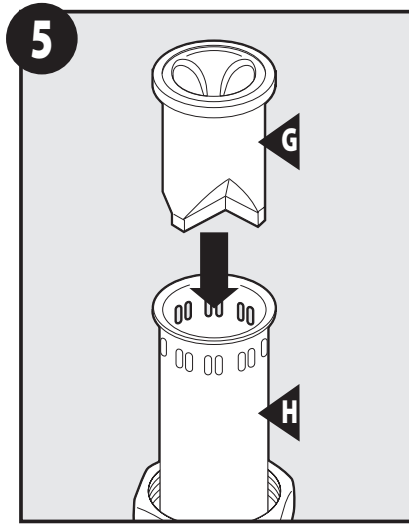
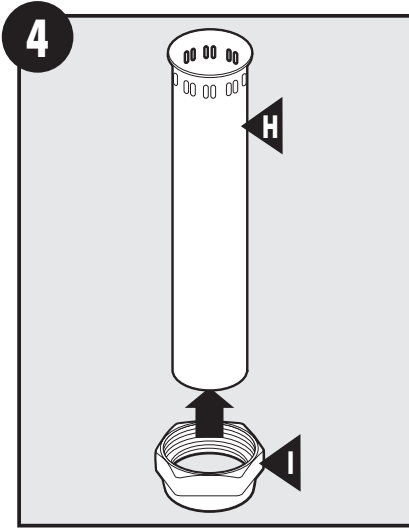



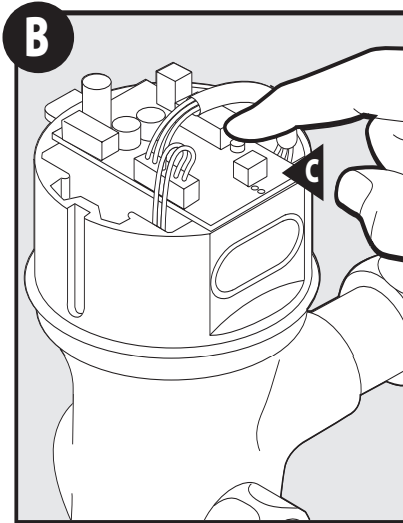
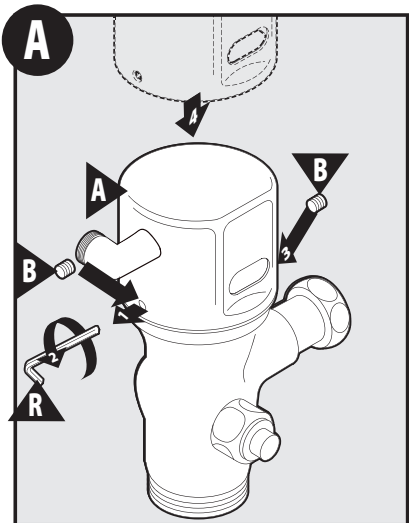
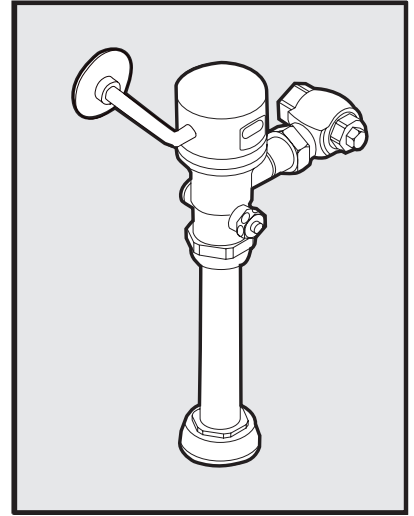
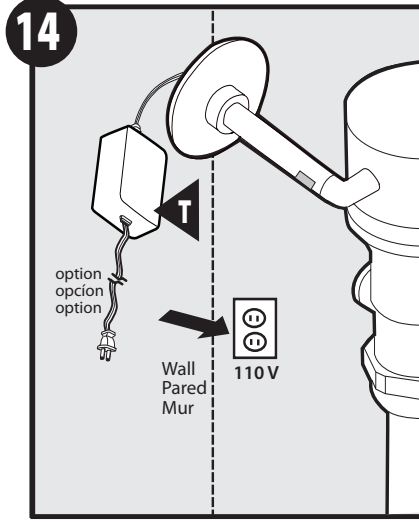
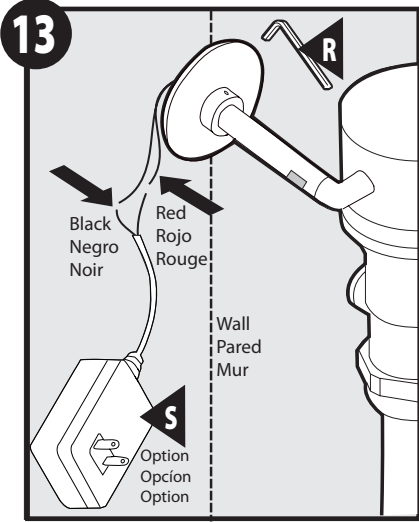

**C**

**Note:**

A. Push the rest button.

B. The following should happen: red light flashes twice, click noise, green light flashes, red light flashes twice. If this happens, then reassemble the cap.

---

**Nota:**

A. Empuje el botón de descanso.

B. Deberá ocurrir lo siguiente: la luz roja emite dos destellos, se oye un clic, la luz verde emite un destello, la luz roja emite dos destellos. Si esto ocurre, vuelva a ensamblar la tapa.

---

**Note:**

A. Appuyer sur le bouton de rétablissement.

B. Voici ce qui devrait se produire : le voyant rouge clignote deux fois, il devrait y avoir un clic, ensuite le voyant vert clignote, puis le voyant rouge clignote deux fois. Après avoir observé ces activités, réassemblez le capuchon.



©2007 Moen Incorporated • 25300 Al Moen Drive • North Olmsted, OH 44070-8022 U.S.A.  
In Canada Moen Inc. • 2816 Bristol Circle • Oakville, Ontario L6H5S7

Moen products have been manufactured under the highest standards of quality and workmanship. Moen warrants to the original consumer purchaser for as long as the original consumer purchaser owns their home (the "Warranty Period" for homeowners), that this faucet will be leak- and drip-free during normal use and all parts and finishes of this faucet will be free from defects in material and manufacturing workmanship. All other purchasers (including purchasers for industrial, commercial and business use) are warranted for a period of 5 years from the original date of purchase (the "Warranty Period" for non-homeowners).

If this faucet should ever develop a leak or drip during the Warranty Period, Moen will FREE OF CHARGE provide the parts necessary to put the faucet back in good working condition and will replace FREE OF CHARGE any part or finish that proves defective in material and manufacturing workmanship, under normal installation, use and service. Replacement parts may be obtained by calling 1-800-289-6636 (Canada 1-800-465-6130), or by writing to the address shown. Proof of purchase (original sales receipt) from the original consumer purchaser must accompany all warranty claims. Defects or damage caused by the use of other than genuine Moen parts is not covered by this warranty. This warranty is applicable only to faucets purchased after December, 1995 and shall be effective from the date of purchase as shown on purchaser's receipt.

This warranty is extensive in that it covers replacement of all defective parts and finishes. However, damage due to installation error, product abuse, product misuse, or use of cleaners containing abrasives, alcohol or other organic solvents, whether performed by a contractor, service company, or yourself, are excluded from this warranty. Moen will not be responsible for labor charges and/or damage incurred in installation, repair or replacement, nor for any indirect, incidental or consequential damages, losses, injury or costs of any nature relating to this faucet. Except as provided by law, this warranty is in lieu of and excludes all other warranties, conditions and guarantees, whether expressed or implied, statutory or otherwise, including without restriction those of merchantability or of fitness for use.

Some states, provinces and nations do not allow the exclusion or limitation of incidental or consequential damages, so the above limitations or exclusions may not apply to you. This warranty gives you specific legal rights and you may also have other rights which vary from state to state, province to province, nation to nation. Moen will advise you of the procedure to follow in making warranty claims. Simply write to Moen Incorporated using the address below. Explain the defect and include proof of purchase and your name, address, area code and telephone number.

Moen Incorporated  
25300 Al Moen Drive  
North Olmsted, Ohio 44070-8022  
U.S.A.

Los productos Moen son fabricados bajo las más estrictas normas de calidad y mano de obra. Moen le garantiza al comprador original que durante el tiempo que la tenga su casa (el "periodo de garantía", para los propietarios), esta llave no tendrá ni goteras ni fugas durante el uso normal, y que todas las piezas y acabados estarán libres de defectos en material y mano de obra. Asimismo, a todos nuestros otros consumidores (industriales, comerciales y empresariales), les otorgamos 5 años de garantía a partir de la fecha original de compra (el "periodo de garantía" para usos no domésticos).

Si en esta llave mezcladora se llegara a producir alguna fuga o gotera durante el periodo de garantía, Moen le proporcionará SIN COSTO ALGUNO las piezas necesarias para que vuelva a funcionar en perfectas condiciones y reemplazará también SIN COSTO para usted, cualquier pieza o acabado que pudiera tener algún defecto en la fabricación o mano de obra, bajo condiciones normales de instalación, uso y servicio. Las piezas de repuesto se pueden obtener llamando en la República Mexicana al 01-800-718-4345 o si escribe en la dirección que aparece aquí. Para que el comprador original pueda hacer efectiva la garantía, cualquier reclamación deberá ir acompañada por el comprobante de compra (nota de venta original). La garantía no cubre los defectos o daños causados por el uso de otras partes que no sean piezas originales Moen. Esta garantía es aplicable sólo para las llaves compradas después de diciembre de 1995, y entrará en vigencia a partir de la fecha que aparece en la nota de compra.

Esta garantía es amplia en el sentido que cubre el reemplazo de todas las partes y acabados defectuosos. Sin embargo, se excluyen de esta garantía los daños causados por un error de instalación, abuso del producto, mal uso del mismo, o uso de limpiadores que contengan abrasivos, alcohol u otros solventes orgánicos, ya sea por parte del contratista, compañía de servicio o usted mismo. Moen no se hace tampoco responsable por los gastos de mano de obra ni por los daños incurridos en la instalación, reparación o sustitución, ni por ningún daño indirecto, directo o consecuente, ni por pérdidas, lesiones o costos de alguna otra índole relacionados con esta llave. A menos que lo estipule la ley, esta garantía reemplaza y excluye cualquier otra garantía y condiciones, ya sea expresas o implícitas, establecidas por la ley o de otra manera, incluyendo sin restricción aquellas en que el producto se encuentra en condiciones aptas para la venta o se adecúa al uso específico para el cual fue adquirido.

Algunos estados, provincias y naciones no permiten la exclusión o limitación de los daños incidentales o consecuentes, de modo que las limitaciones o exclusiones mencionadas pueden no ser aplicables a usted. Esta garantía le otorga derechos legales específicos y usted puede también tener otros derechos que cambian de un estado a otro o de una provincia o nación a otra. Moen lo asesorará en el procedimiento a seguir para hacer válida esta garantía. Sencillamente escriba a Moen Incorporated utilizando la dirección que aparece a continuación. Explique el tipo de defecto e incluya comprobantes de compra, su nombre, dirección, código de área y número de teléfono.

Moen de Mexico, S.A. de C.V.  
Carretera Saltillo-Monterrey KM 14.7  
Ramos Arizpe, Coahuila  
Mexico 25900

Les produits Moen sont fabriqués selon les normes les plus élevées de qualité et de main-d'œuvre. Moen garantit à l'acheteur original, tant qu'il sera propriétaire de la maison (la «période de garantie» des propriétaires), que ce robinet sera libre de toute fuite pendant son usage normal et qu'aucune pièce et qu'aucun fini de ce robinet ne présenteront de défaut de matériel et de main-d'œuvre en usine. Tous les autres achats (y compris les achats à des fins industrielles, commerciales et d'affaires) sont garantis pendant cinq (5) ans à compter de la date d'achat originale (période de garantie commerciale).

Si ce robinet fuit ou dégoutte durant la période de garantie, Moen s'engage à fournir GRATUITEMENT les pièces de rechange requises pour remettre le robinet en état de fonctionnement ainsi qu'à remplacer GRATUITEMENT toute pièce ou tout fini dont le matériel, la fabrication ou la main-d'œuvre, lors de l'installation, de l'usage et du service habituels, s'avèrent défectueux. On peut obtenir les pièces de rechange en composant le 1 800 465-6130 ou en écrivant à l'adresse indiquée ci-dessous. Le reçu de vente original de l'acheteur initial du robinet doit accompagner toute réclamation. Les défauts ou les dommages causés par l'utilisation de pièces non fournies par Moen ne sont pas couverts par cette garantie. Cette garantie s'applique uniquement aux robinets achetés après décembre 1995 et entre en vigueur à compter de la date d'achat indiquée sur le reçu de caisse du client.

Cette garantie s'étend aussi au remplacement de toute pièce ou de tout fini défectueux. Cependant, sont exclus de cette garantie, les dommages causés par une erreur d'installation, un abus du produit, une mauvaise utilisation du produit, l'utilisation de produits de nettoyage contenant des agents abrasifs, de l'alcool ou des solvants organiques, qu'ils soient utilisés par un entrepreneur, une entreprise de service ou le consommateur. Moen décline toute responsabilité quant aux frais de main-d'œuvre et aux dommages causés durant l'installation, la réparation ou le remplacement, et aux dommages, pertes, blessures ou coûts, indirects ou consécutifs, connexes à ce robinet. Sauf lorsque la loi le stipule, cette garantie remplace et exclut toutes les autres garanties et conditions, qu'elles soient indiquées expressément ou non, obligatoires ou autres, y compris, sans restriction, celles qui visent la commercialisation ou l'aptitude d'utilisation.

Certains pays, états ou provinces ne permettent aucune exclusion, ni limitation suite aux dommages indirects ou consécutifs. Les limitations ou les exclusions précitées ne s'appliqueraient pas dans ces cas. Cette garantie accorde des droits juridiques et il est possible que d'autres droits soient applicables selon l'état, la province ou le pays. Moen avisera le consommateur de la procédure à suivre pour soumettre une réclamation. Il suffit d'écrire à Moen inc. à l'adresse indiquée ci-dessous, pour expliquer le défaut, d'inclure une preuve d'achat, d'inscrire son nom, son adresse ainsi que son indicatif régional et son numéro de téléphone.

Moen Inc.  
2816 Bristol Circle  
Oakville, Ontario L6H 5S7

## Battery-Powered Flush Valves

## AC-Powered Flush Valves

# Sensor-Operated Flush Valves

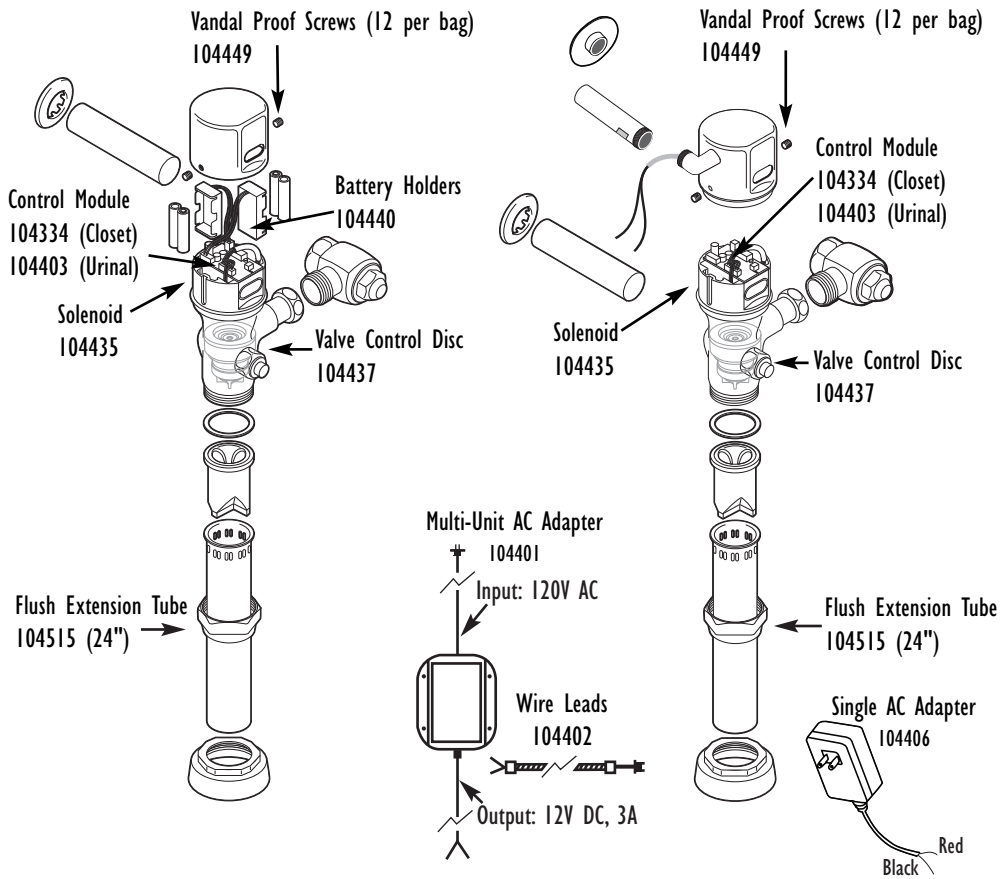

AC-POWERED

BATTERY-POWERED

BATTERY-POWERED RETRO-FIT KITS



### Service Kit Parts

Model	Description	Model	Description
104334	Control Module (Closet)	104505	4-1/4" Delany Ext. Nipple
104401	Multi-unit AC Adapter (up to 8)	104506	2-1/8" Ext. Nipple Moen-Sloan-Zum
104402	24" Wire Leads	104507	2-1/2" Ext. Nipple Moen-Sloan-Zum
104403	Control Module (Urinal)	104508	3" Ext. Nipple Moen-Sloan-Zum
104406	Single AC Adapter	104509	3-1/2" Ext. Nipple Moen-Sloan-Zum
104435	Flush Valve Solenoid Coil Kit	104510	4" Ext. Nipple Moen-Sloan-Zum
104437	Flush Valve Control Disc Valve	104511	4-1/2" Ext. Nipple Moen-Sloan-Zum
104440	Flush Valve Battery Holder (2/bag)	104512	5" Ext. Nipple Moen-Sloan-Zum
104449	Vandal Proof Screws (12/bag)	104513	5-1/2" Ext. Nipple Moen-Sloan-Zum
104500	2-1/4" Delany (standard) Ext. Nipple	104514	6" Ext. Nipple Moen-Sloan-Zum
104501	1-3/4" Delany Ext. Nipple	104515	Flush Extension Tube-24"
104502	2-3/4" Delany Ext. Nipple	104516	Split Ring Support
104503	3-1/4" Delany Ext. Nipple	104517	Trap Primer
104504	3-3/4" Delany Ext. Nipple		

**MOEN**<sup>®</sup>  
COMMERCIAL

Owner's Manual

Moen Incorporated • 25300 Al Moen Drive • North Olmsted, OH 44070-8022

For more information call Moen Specifier Services 1-800-321-8809 ext. 2158 or email [specmoen@moen.com](mailto:specmoen@moen.com)

**Battery-Powered & AC-Powered Flush Valves**

Normal Operation: When new batteries are inserted or AC power is connected or RESET Button is pushed, the lights on the Printed Circuit Board (PCB) will blink in the following sequence: Red, Red (with solenoid clicking), Green, Red and Red. Green light will stay on. When the user enters the sensor beam's effective range, the red light will flash one time on battery-operated flush valves and will stay on on AC-powered models. If the user stays in the effective range for more

than 4 seconds and steps away, the valve will activate (1) flush cycle. The flush valve unit will automatically reset for the next user. When the manual OVERRIDE Button is pushed, the flushing mechanism will be activated without impacting the mode of automatic operation. On battery operated models, the red indicator light flashes when batteries are low. Please note: Always push the RESET Button BEFORE diagnosing any problem and AFTER taking a corrective action.

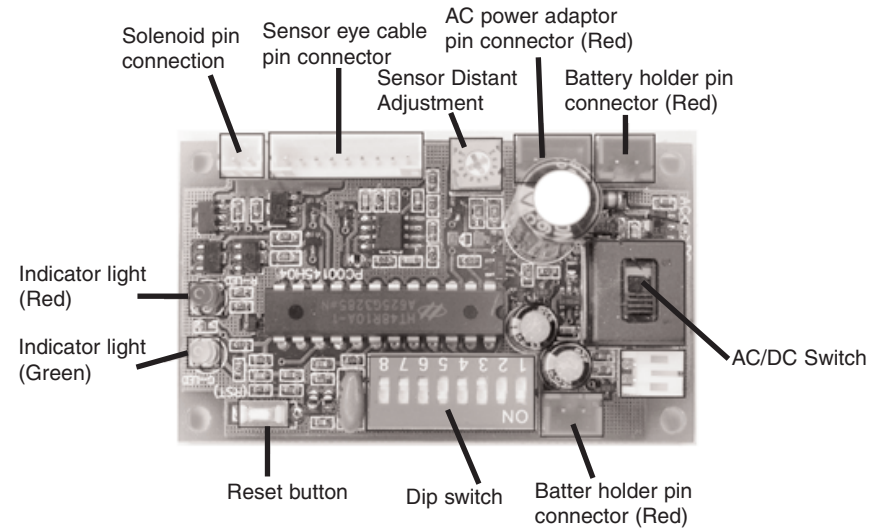

PROBLEM - FLUSH VALVE WILL NOT FLUSH		
POSSIBLE CAUSE	TO DIAGNOSE	REMEDY
Water not turned on	Check water supply	Turn water on.
Power supply failure	Check polarity of batteries (or Power Adapter voltage), and connections.	Replace batteries (or Power Adapter), re-connect. Push RESET Button.
Batteries are weak.	Red indicator light flashes, no click.	Replace batteries and push RESET Button.
Sensor distance is too short	Stand in front of Flush Valve to find focal point of sensor beam.	To adjust sensor distance out, turn adjustment clockwise. Push RESET Button.
Electronic PCB is defective.	Change batteries (or with Power Adapter plugged in) push RESET Button. No light, no action.	Replace PCB. Push RESET Button.
Sensor eyes are defective.	Re-insert batteries (or with Power Adapter plugged in), stand in front of sensor eyes. If Red indicator light does not blink.	Replace sensor eyes and cable.
Sensor eye angle too low/too high.	Beam not detecting user.	Disassemble control unit, rotate lens up/down with finger.
Solenoid Valve is clogged.	Solenoid is clicking but no water.	Clean solenoid and blow free all by-pass holes. Replace Control Disc. Push RESET Button.
In-line Filter is clogged	Open clean-out trap, check filter screen.	Clean or replace filter screen.
User time in sensor range too short	Stand in front of Flush Valve. Red indicator light does (1) flash.	Stand in sensor for more than 4 seconds, then move away.
Solenoid Coil is defective.	Insert new batteries (or with Power Adapter plugged in), push RESET Button. Light blinks but no solenoid clicking.	Replace solenoid coil. Push RESET Button.
PROBLEM: FLUSH VALVE WILL NOT SHUT OFF		
Solenoid is dirty	Solenoid valve is normally closed. Turn off water and activate flush valve. Clicking sound means the solenoid is dirty. If there is no clicking sound.....	then replace solenoid valve.

**Note: Worn batteries are the leading cause of malfunctions. Replace batteries regularly.**

**Electronic Flush Valves**

**Dip Switch Settings - Push reset button on PC board after any dip switch adjustments**

Diagram #		Flushing Volume (Time) Water Closet or Urinal								Sensor Arming Time (Sensing Time Required For Flush)				
		Moen SKU	Flush Time	GPF	SW 1	SW 2	SW 3	SW 4	SW 5	SW 6	SW 7	SW 8	Arming Time	
1	Urinal Factory pre-set	8312 8314 8312R10	2 SEC	1	ON	ON	ON	OFF	OFF	OFF	OFF	ON	3 SEC	
2	Urinal Factory pre-set	8312R15	3 SEC	1.5	ON	ON	OFF	ON	OFF	OFF	OFF	ON	3 SEC	
3	Closet Factory pre-set	8310 8310R16	3 SEC	1.6	ON	ON	OFF	ON	ON	OFF	OFF	OFF	4 SEC	
4	Closet Factory pre-set	8310R35	7 SEC	3.5	ON	OFF	OFF	ON	ON	OFF	OFF	OFF	4 SEC	
5	Optional	Urinal	1 SEC	0.5	ON	ON	ON	ON	OFF	OFF	OFF	ON	3 SEC	
6	Optional	Closet	4 SEC	2	ON	ON	OFF	OFF	ON	OFF	OFF	OFF	4 SEC	

