



SERVICE PARTS LIST

BULLETIN NO.
54-24-5262

SPECIFY CATALOG NO. AND SERIAL NO. WHEN ORDERING PARTS		REVISED BULLETIN	DATE
1" D-HANDLE ROTARY HAMMER			Feb. 2022
CATALOG NO.	5262-21	SERIAL NUMBER	G43A
		WIRING INSTRUCTION See page 6	

EXAMPLE:
Component Parts (Small #) Are Included
When Ordering The Assembly (Large #).

● = Component of the 14-46-5265
5262-21 Maintenance Service Kit

**SEE PAGE TWO FOR THE PROCEDURE
ON CHECKING THE STATIC SLIP
VALUES OF THE CLUTCH**

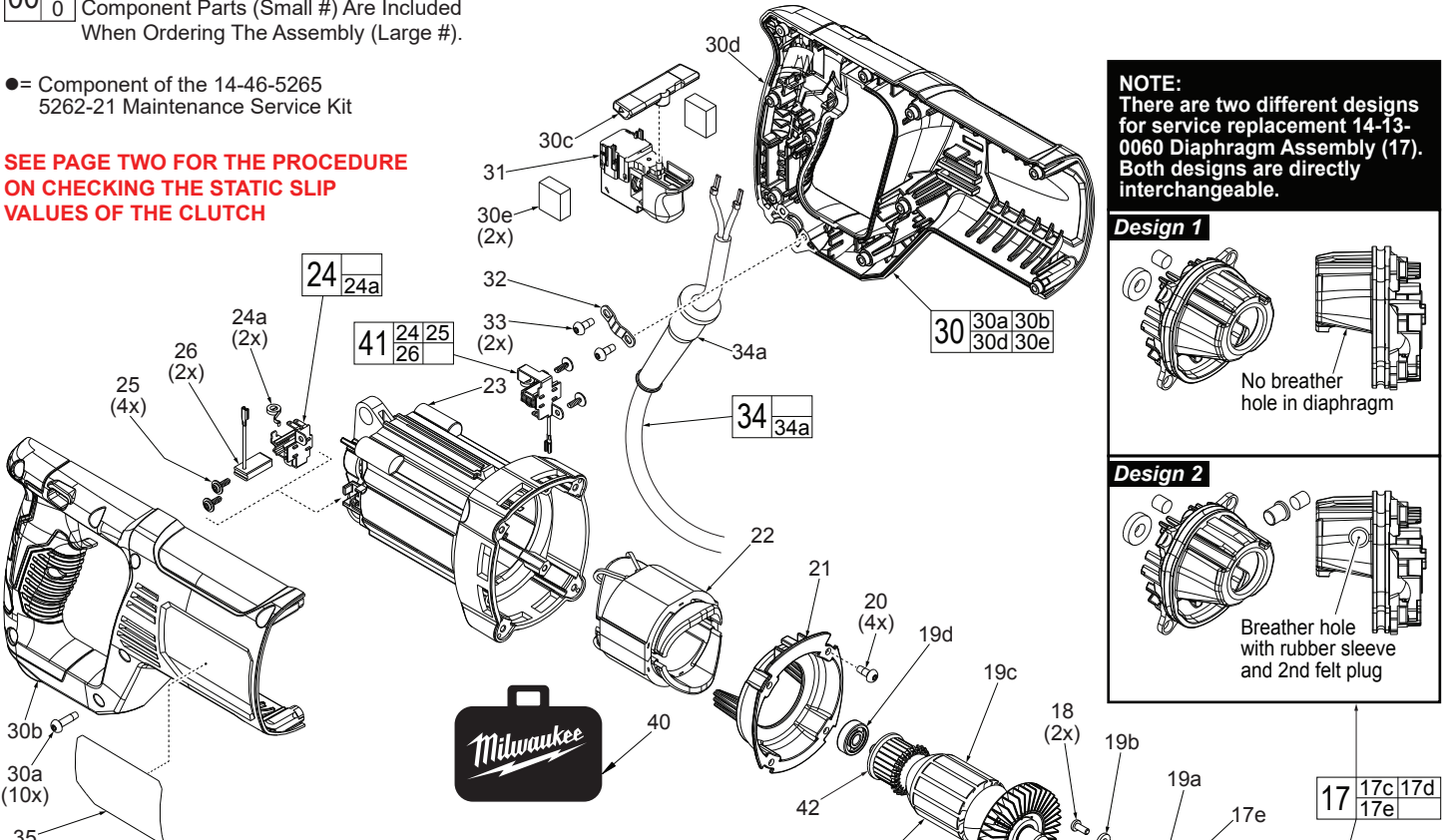

NOTE:
There are two different designs for service replacement 14-13-0060 Diaphragm Assembly (17). Both designs are directly interchangeable.

Design 1

No breather hole in diaphragm

Design 2

Breather hole with rubber sleeve and 2nd felt plug

FIG.	PART NO.	DESCRIPTION OF PART	NO. REQ.
17	14-13-0060	Diaphragm Assembly w/ Bushing	(1)
17a	43-44-1375	● Gasket	(1)
17c	-----	Diaphragm w/ Bushing	(1)
17d	43-84-0300	Felt Plug	(1)
17e	45-06-5263	Seal Ring	(1)
18	05-78-0105	M4 x 10mm Pan Hd. Tapt. T-20 Screw	(2)
19	16-10-0102	120V Armature Assembly	(1)
19a	02-04-0039	Ball Bearing	(1)
19b	44-66-0117	Bearing Retaining Plate	(1)
19c	-----	Armature	(1)
19d	02-04-5382	Ball Bearing	(1)
20	05-78-5313	M4 x 9mm Pan Hd. Plast. T-15 Screw	(4)
21	42-14-0112	Fan Baffle	(1)
22	18-01-0032	120V Field Assembly	(1)
23	28-50-0052	Motor Housing	(1)
24	22-20-0029	Brush Holder	(2)
24a	-----	Brush Spring	(2)
25	05-88-0030	M3 x 8.5mm Pan Hd. ST T-10 Screw	(4)
26	22-18-0032	● 120V Carbon Brush	(2)
27	23-94-0033	Leadwire Assembly-Red (See page 5)	(1)
28	23-94-0037	Leadwire Assembly-Blue (See page 5)	(1)
29	36-92-0010	Reduction Gear Assembly	(1)
29a	44-90-1180	● C-Ring	(1)
29b	32-60-1611	2nd Stage Pinion	(1)
29c	36-66-0026	Reduction Gear Shaft	(1)
29d	45-22-0927	Coupler	(1)
29e	40-50-2141	Shift Spring	(1)
29f	45-22-0926	Wobble Coupler	(1)
29g	36-92-5263	Wobble Bearing	(1)
29h	32-75-0027	1st Stage Gear	(1)
29j	44-66-0022	Retaining Plate	(1)
29k	02-04-5385	Ball Bearing	(1)
29m	06-82-0017	● M4 x 10mm T-15 Screw	(1)
30	14-34-0025	Housing Assembly	(1)
30a	06-82-0995	M4 x 16mm Pan Hd. Plast. T-20 Screw	(10)

FIG.	PART NO.	DESCRIPTION OF PART	NO. REQ.
19	19a 19b 19c 19d 42	120V Armature Assembly	(1)
17	17c 17d 17e	Diaphragm Assembly w/ Bushing	(1)
30b	-----	Housing Halve - Right	(1)
30c	45-34-0017	Forward/Reverse Lever	(1)
30d	-----	Housing Halve - Left	(1)
30e	44-52-0025	Foam Pad	(2)
31	23-66-0013	120V Switch	(1)
32	42-68-0601	Cord Clamp	(1)
33	05-78-5313	M4 x 9mm Pan Hd. Plast. T-15 Screw	(2)
34	22-64-0027	120V Power Cord	(1)
34a	44-76-0210	Strain Relief	(1)
35	12-20-5261	Service Nameplate	(1)
36	05-74-1030	● M5 x 8mm Pan Hd. Tapt. T-25 Screw	(2)
40	42-55-5263	Blow Molded Carrying Case	(1)
41	22-22-0043	Brush Service Kit (Set of 2)	(1)
42	23-16-0092	Commutator Insulator	(1)
29	29a 29b 29c 29d 29e 29f 29g 29h 29j 29k 29m	Reduction Gear Assembly	(1)

MILWAUKEE ELECTRIC TOOL CORPORATION
13135 W. LISBON RD., BROOKFIELD, WI 53005
Drwg. 2

IMPORTANT:

Rounded side of Washers (14) must be placed facing the inside surface of Piston (13) as shown.

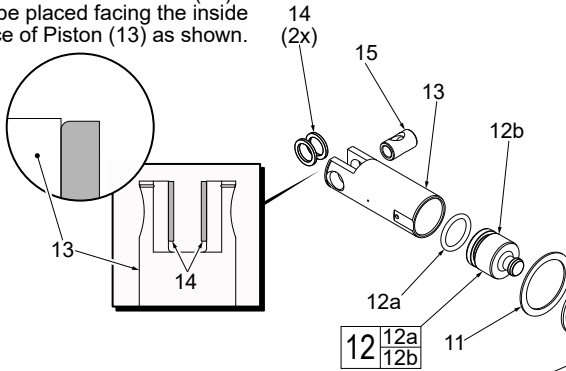

To check the static slip values of the clutch you must do the following:

- Position Red spring loaded shifting lever at the hammer only icon.
- Lock motor housing of tool into the jaws of a vise having brass jaws or the equivalent.
- Insert a SDS Plus adaptor* into spindle.
- Turn torque wrench clockwise as viewed from the front of the tool until the single slip cycle has been accomplished. Observe the torque reading. Slip clutch a minimum of three times for the most accurate reading.

*SDS Plus Adaptor being used is made by threading a 1/2" x 20 hex nut onto the threads of SDS adaptor No. 48-03-3005.
Note: Apply RED Loctite to threads of hex nut prior to tightening.

Max = 240in/lbs or 20ft/lbs • Min = 150in/lbs or 12.5ft/lbs

●14-46-5265 Rotary Hammer Service Kit

2	42-52-5262	Dust Cap	(1)
3	31-58-0037	Chuck Sleeve	(1)
4	44-90-0014	C-Ring	(2)
10c	34-40-1425	O-Ring	(1)
10e	34-40-0018	O-Ring	(1)
10f	34-40-1410	O-Ring	(1)
10h	34-40-1440	O-Ring	(1)
10k	44-90-1026	Snap Ring	(1)
10s	44-90-0216	C-Ring (Thicker)	(1)
10t	44-90-0215	C-Ring (Thinner)	(1)
12a	34-40-1511	O-Ring	(1)
14	45-88-5200	Washer	(2)
17a	43-44-1375	Gasket	(1)
26	22-18-0032	Carbon Brush	(2)
29a	44-90-1180	C-Ring	(1)
29m	06-82-0017	M4.0 x 0.7 Screw	(1)
36	05-74-1030	Taptite Screw	(2)
	49-08-5355	'Q2' Grease 2.8 oz. tube	(1)
	49-08-5262	'S2' Grease 1.4 oz. tube	(2)

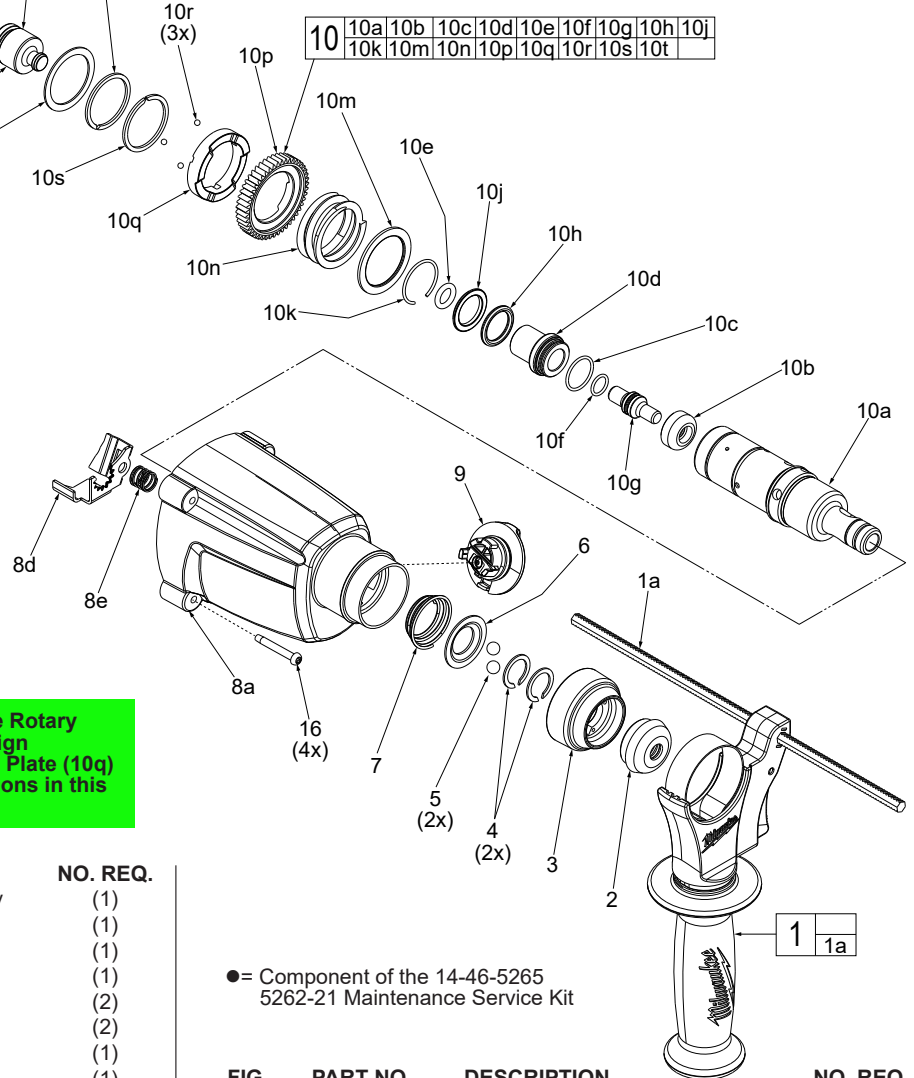

SERVICE NOTE: When installing components of the Rotary Hammer Service Kit (●14-46-5265), please note design differences to the 5262-21. Spindle (10a) and Clutch Plate (10q) will be either a 3 ball or 6 ball design (10r). Illustrations in this service parts list reflect the original 3 ball design.

FIG.	PART NO.	DESCRIPTION OF PART	NO. REQ.
1	14-34-5262	Auxiliary Side Handle Assembly	(1)
1a	44-94-5381	Depth Gage Rod	(1)
2	42-52-5262	● Rubber Cap	(1)
3	31-58-0037	● Chuck Sleeve	(1)
4	44-90-0014	● C-Ring	(2)
5	02-02-0275	Steel Ball	(2)
6	42-36-0191	Ball Plate	(1)
7	40-50-5262	Conical Spring	(1)
8a	28-14-0013	Gearcase w/ Bushing, Bearings, Seal & Screw	(1)
8d	44-90-1011	Lock Plate	(1)
8e	40-50-0870	Lock Plate Spring	(1)
9	44-10-5264	Shift Knob Assembly	(1)
10	32-75-0021	SDS Spindle and Gear Assembly	(1)
10a	-----	SDS Spindle	(1)
10b	43-06-0040	Brake Ring	(1)
10c	34-40-1425	● O-Ring	(1)
10d	45-22-0870	Anvil Sleeve	(1)
10e	34-40-0018	● O-Ring	(1)
10f	34-40-1410	● O-Ring	(1)
10g	45-08-0650	Anvil	(1)
10h	34-40-1440	● O-Ring	(1)
10j	42-76-1001	Washer	(1)
10k	44-90-1026	● Snap Ring	(1)

● = Component of the 14-46-5265 5262-21 Maintenance Service Kit

FIG.	PART NO.	DESCRIPTION	NO. REQ.
10m	45-88-2115	Washer	(1)
10n	40-50-1721	Clutch Spring	(1)
10p	32-75-1831	2nd Stage Gear	(1)
10q	-----	Clutch Plate	(1)
10r	-----	Steel Ball	(6)
10s	44-90-0216	● C-Ring (Thicker than 10t)	(1)
10t	44-90-0215	● C-Ring	(1)
11	45-88-0026	Washer	(1)
12	45-56-0037	Striker Assembly	(1)
12a	34-40-1511	● O-Ring	(1)
12b	-----	Striker	(1)
13	44-62-0058	Piston	(1)
14	45-88-5200	● Washer	(2)
15	44-60-0033	Wrist Pin	(1)
16	06-81-5383	M4 x 35mm Pan Hd. Plast. T-20 Screw	(4)

LUBRICATION NOTES: Type 'S2' Grease
 No. 49-08-5262, 1.4 oz. / 40g tube (2 included)
 Approximately 2.1 oz. / 60g needed

Lubrication Note: MILWAUKEE recommends that scheduled maintenance of this Rotary Hammer include lubrication replacement, and replacement of vital O-rings and gaskets at each carbon brush change. Doing so will prolong the life of the hammer by reducing wear to gears and mechanism parts. The carbon brushes and armature commutator in this MILWAUKEE Rotary Hammer are designed and matched for many hours of reliable performance.

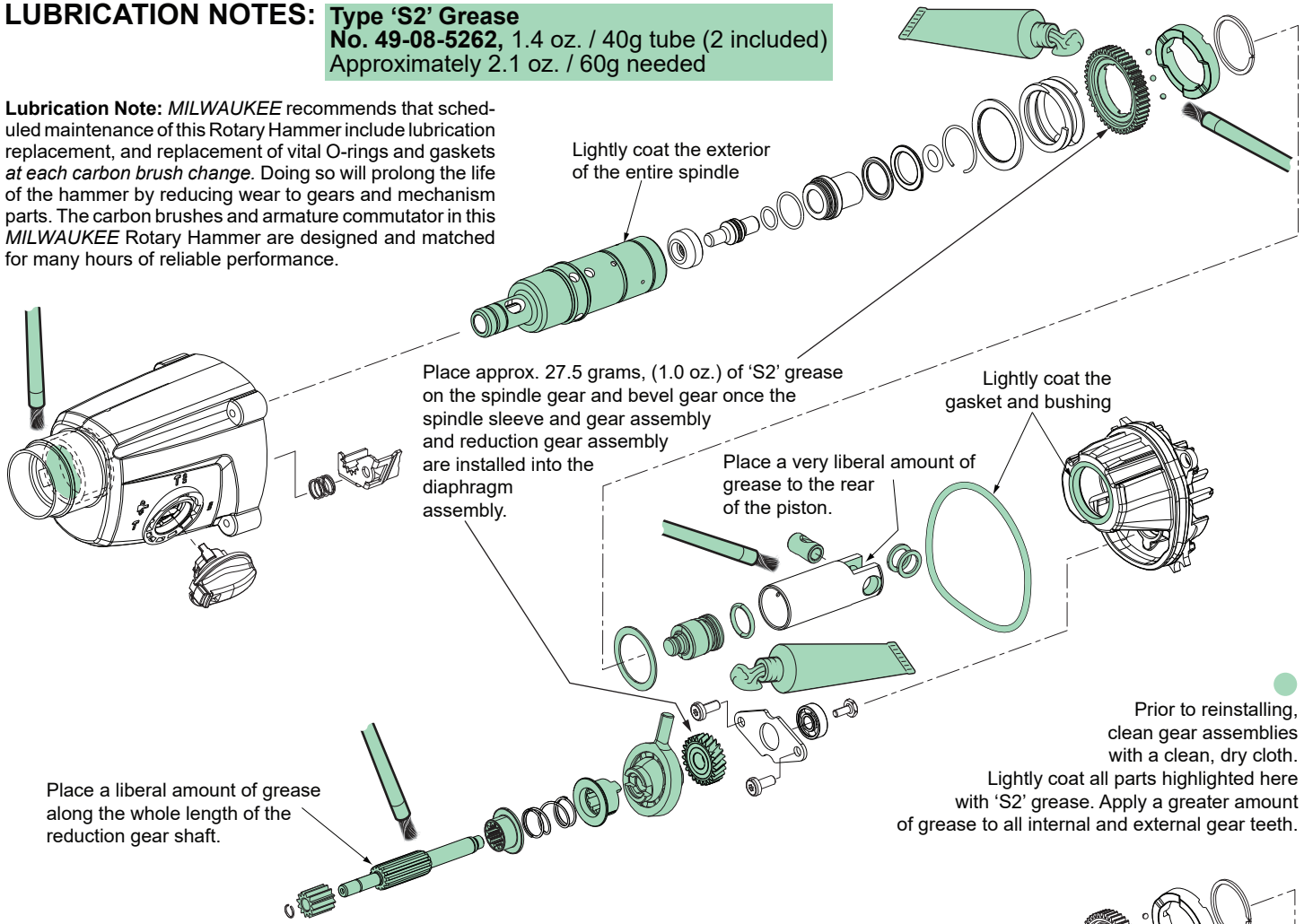

LUBRICATION NOTES: Type 'Q2' Grease
 No. 49-08-5355, 2.8 oz. / 80g tube
 Approximately .3 oz. / 8.7g needed

Lightly coat all parts highlighted here with 'Q2' grease unless directed otherwise.

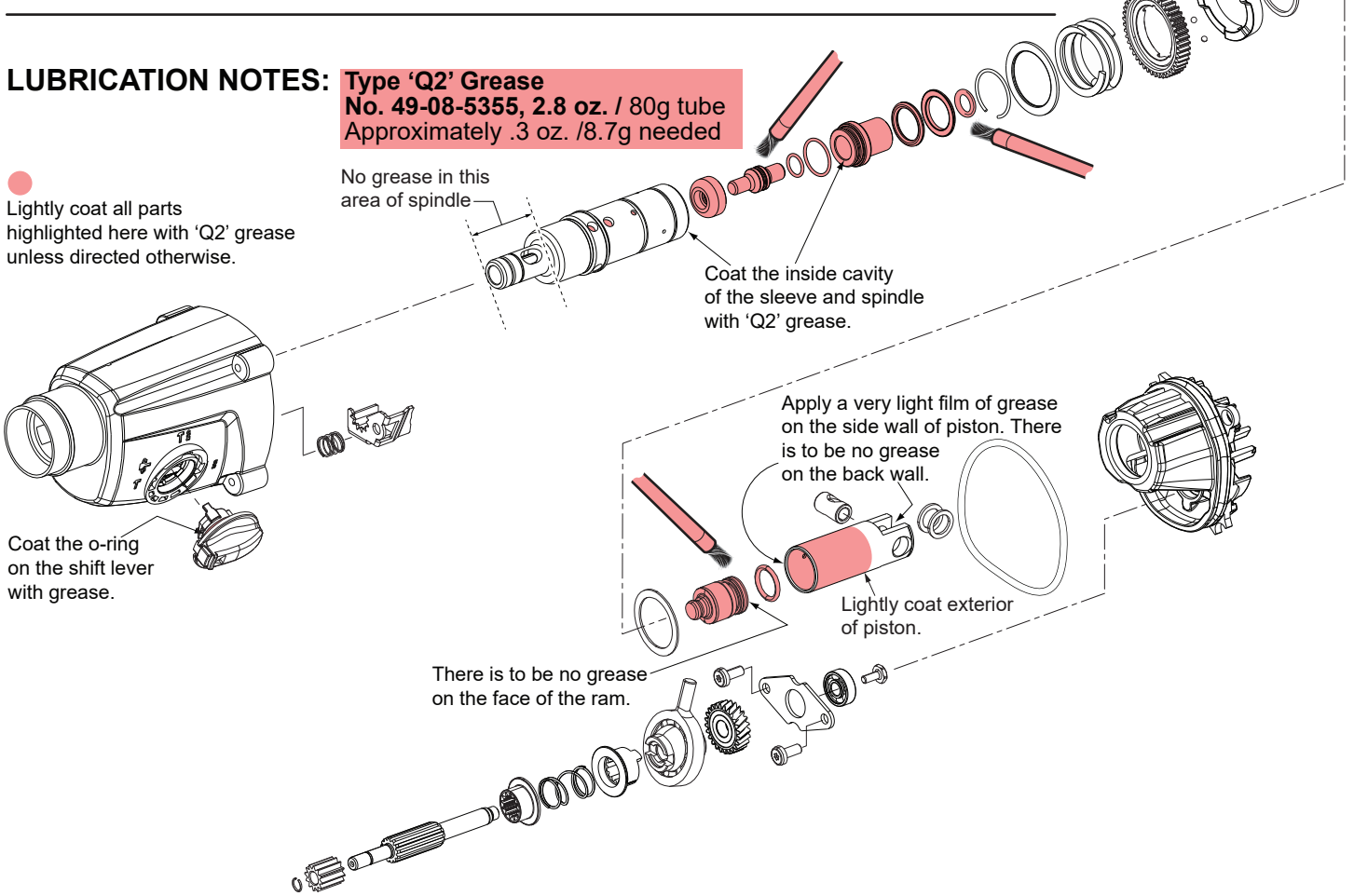

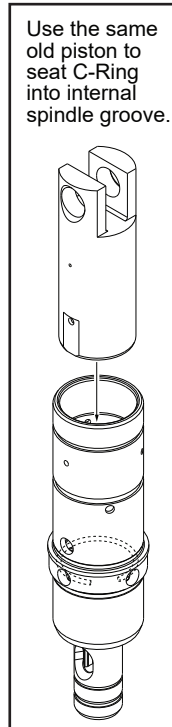
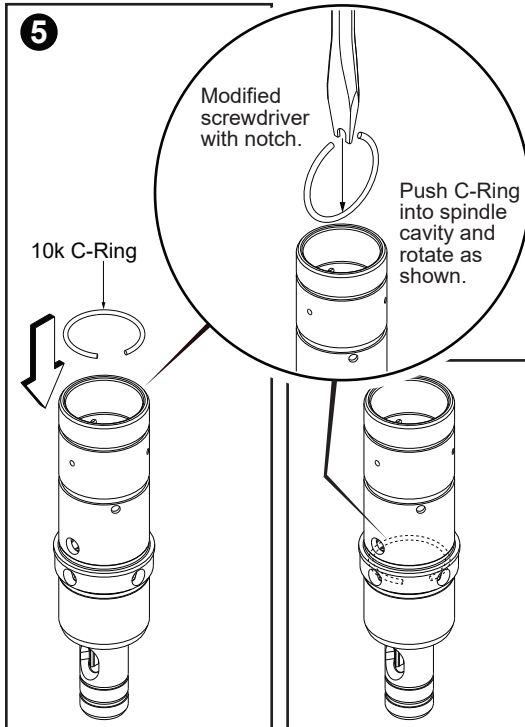
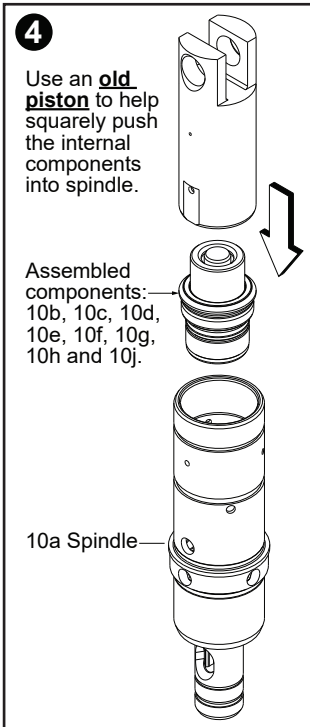
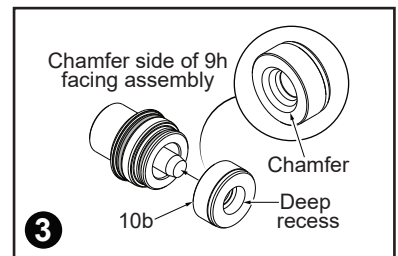
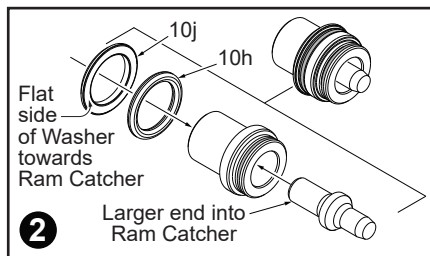
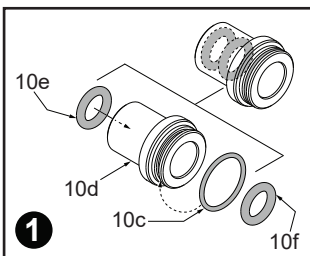

Assembly of internal Spindle components:

1. Lubricate Ram Catcher and O-Rings. Assemble O-Rings onto and into Ram Catcher.
2. Assemble Anvil Assembly into Ram Catcher Assembly (large end into Ram Catcher as shown).
3. Place the chamfered end of the Stop Washer over the small end of the Anvil.
4. Place the assembled components from step 4 into the cavity of an old piston as shown. Use the old piston as an aid to push the assembled components deep into the Spindle cavity.
5. C-Ring (10k) will be used to secure internal components inside the spindle. *It is recommended to modify a flat blade screwdriver by filing or grinding a notch into the blade.* Place the C-Ring upright as shown with the opening of the ring straight up. Use the modified screwdriver to push the C-Ring down into the Spindle cavity. Rotate the C-Ring in the spindle cavity as shown. Place the old piston into the Spindle cavity and tap the piston with a mallet to secure the C-Ring in the groove.

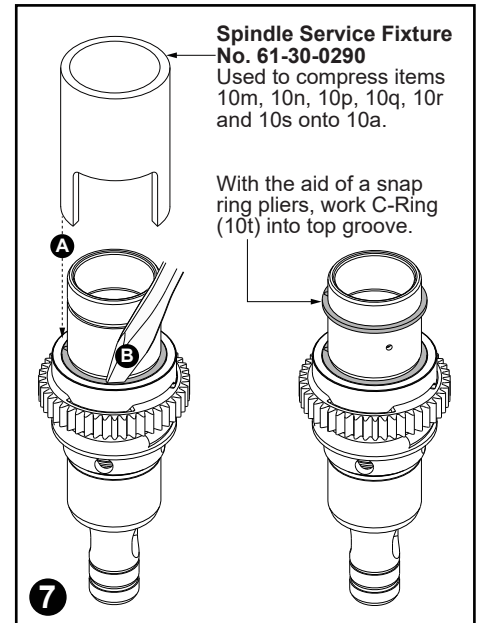
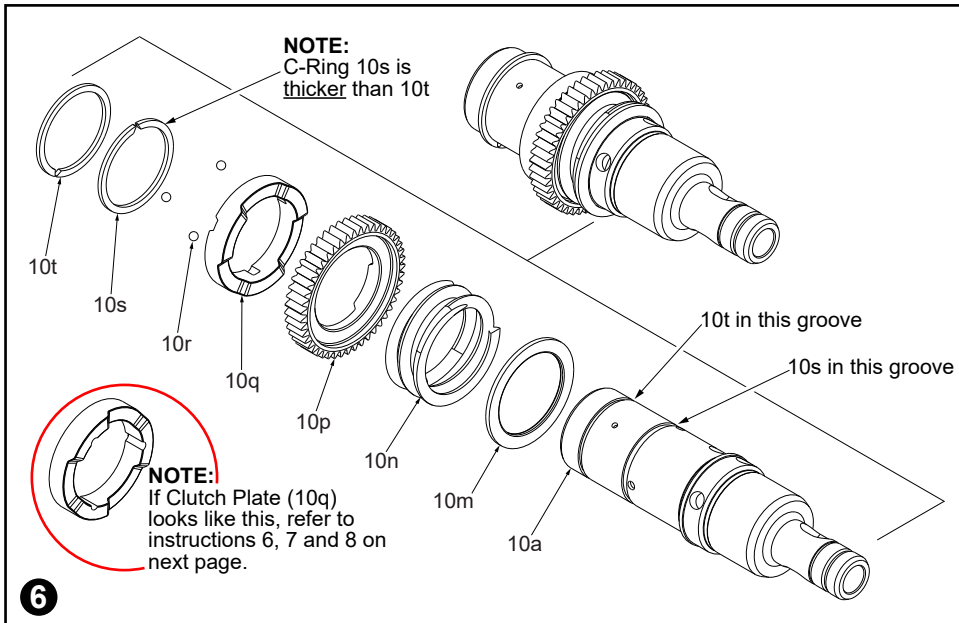

Assembly of external Spindle components:

6. Install Washer 10m and Spring 10n onto spindle. Lubricate and install the Clutch Gear 10p and Clutch Plate 10q onto the Spindle. Be sure to orient the part as shown and position with the three notches on the back of the plate over the holes in the spindle.

Place C-Ring 10s onto Spindle. (C-Ring 10s has a thicker cross section than C-Ring 10t.) With the aid of a snap ring pliers, work the C-Ring past the first spindle groove down to the other parts assembled onto spindle.

7. Place Spindle Service Fixture 61-30-0290 over the assembled parts and the Spindle. Position so the fixture rests on Clutch Plate 10q. Be sure the three notches are not covered. Place the fixture and spindle assembly in an arbor press and carefully compress the Clutch Spring enough to expose the three holes in the Spindle. As an aid, put a dab of grease on your finger to pick up and place the three Steel Balls 10r into the three small holes on the Spindle just above Clutch Plate. Ensure the notches in the Clutch Plate are aligned with the Steel Balls.

While compressed **A**, use a screwdriver **B** to work C-Ring 10s into the Spindle groove. Ensure the Steel Balls are in place and slowly retract the arbor press. The Clutch Plate should slide over the Steel Balls until it is in contact with the C-Ring.

Place C-Ring 10t onto Spindle. With the aid of a snap ring pliers, work the C-Ring into the first spindle groove and snap into place.

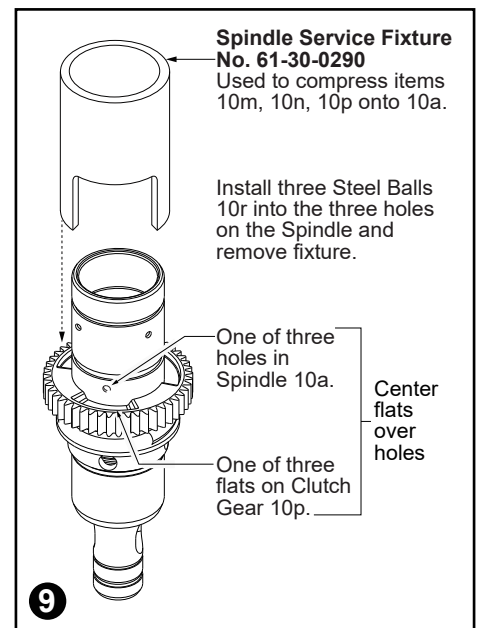
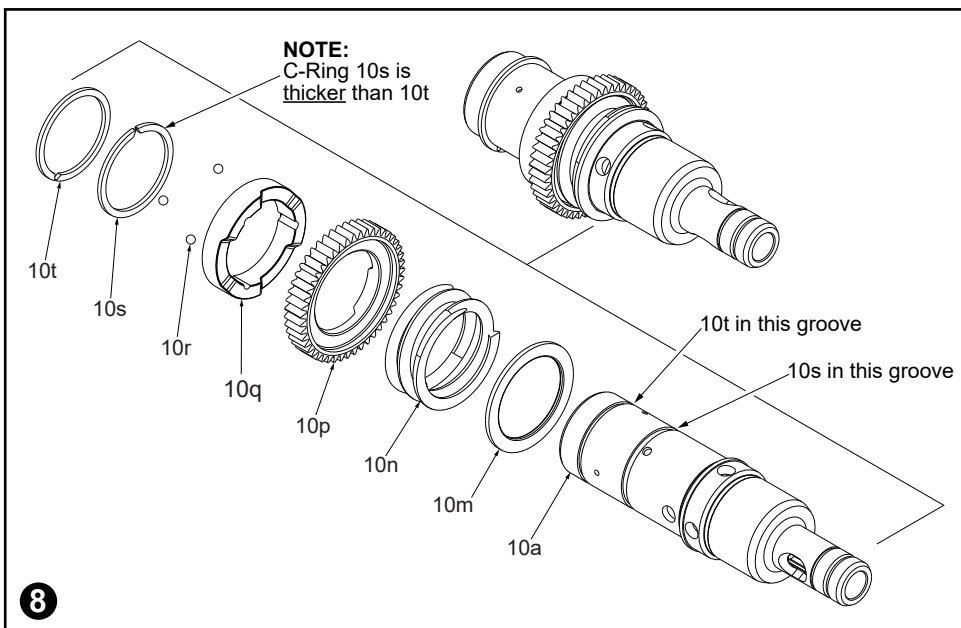

Assembly of external Spindle components:

8. Install Washer 10m and Spring 10n onto spindle. Lubricate and install the Clutch Gear 10p onto the Spindle 10a. Be sure to orient the part as shown with the three flats on the Clutch Gear centered over the holes in the spindle.
9. Place Spindle Service Fixture 61-30-0290 over the assembled parts and the Spindle. Position so the fixture rests on the Clutch Gear 10p. Be sure the three holes on the Spindle are not covered. Place the fixture and spindle assembly in an arbor press and carefully compress the Clutch Spring enough to expose the three holes in the Spindle.

As an aid, put a dab of grease on your finger to pick up and place the three steel balls 10r into the three small holes on the Spindle just above the Clutch Gear.

Remove the Spindle from the arbor press.

10. Lubricate and install the Clutch Plate 10q onto the Spindle. Be sure to orient the part such that three inside notches on the plate cover the Steel Balls in the Spindle. Place the C-Ring 10s onto the Spindle. (**NOTE:** C-Ring 10s has a thicker cross-section than C-Ring 10t). With the aid of a snap ring pliers, work the C-Ring past the first spindle groove, down to the other parts assembled onto the spindle.

Place Spindle Service Fixture 61-30-0290 over the assembled parts and the Spindle. Place the fixture and spindle assembly in an arbor press and carefully compress the Clutch Spring enough to expose the C-Ring groove in the Spindle.

While compressed, use a flat blade screwdriver to work C-Ring 10s into the spindle groove. Ensure that the Steel Balls are still in the spindle. Slowly retract the arbor press. The Clutch Plate should slide over the Steel Balls until it is in contact with the C-Ring.

With the aid of a snap ring pliers, work C-Ring 10t into top groove of Spindle.

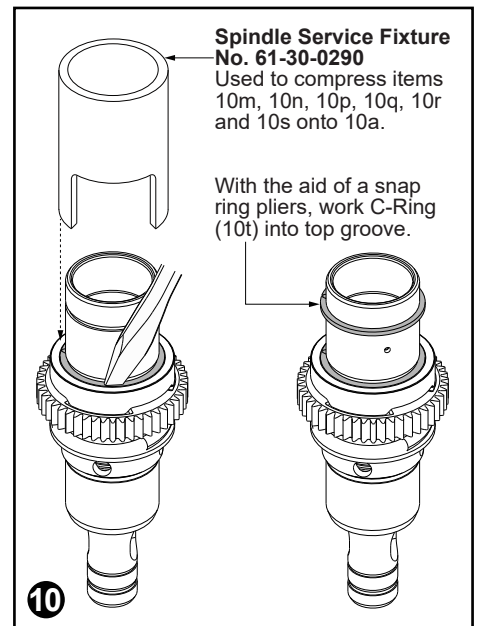

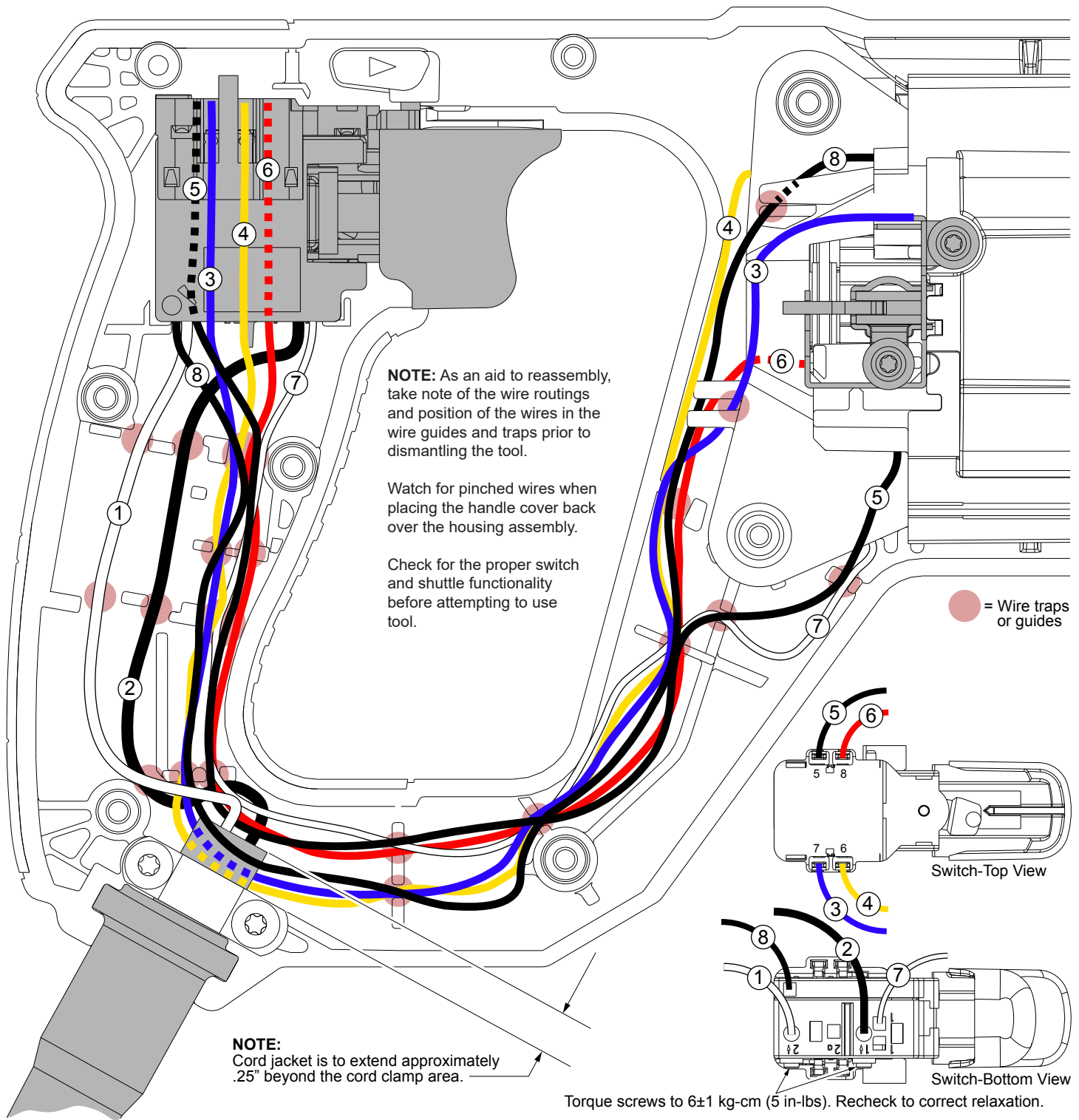

WIRING SPECIFICATIONS

Wire No.	Wire Color	Origin or Gauge	Length	Terminals, Connectors and 1 or 2 End Wire Preparation
1	White	-----	-----	Component of cord set. Connect to '2↓' position on bottom of switch.
2	Black	-----	-----	Component of cord set. Connect to '1↓' position on bottom of switch.
3	Blue	23-94-0037	-----	Connect to position '7' on right side of switch and the right brush holder.
4	Yellow	-----	-----	From top left field coil to position '6' on right side of switch.
5	Black	-----	-----	From bottom right field coil to position '5' on left side of switch.
6	Red	23-94-0033	-----	Connect to position '8' on switch and the left brush holder.
7	White	-----	-----	From bottom left field coil to position '1' on bottom of switch.
8	Black	-----	-----	From top right field coil to '2' on bottom of switch.