

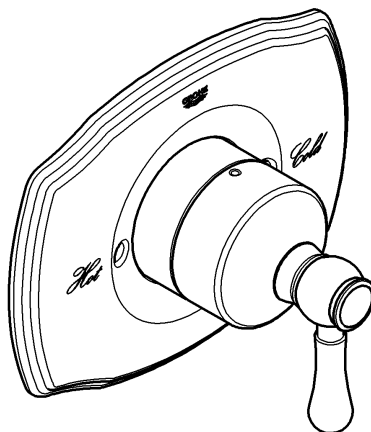

19 843

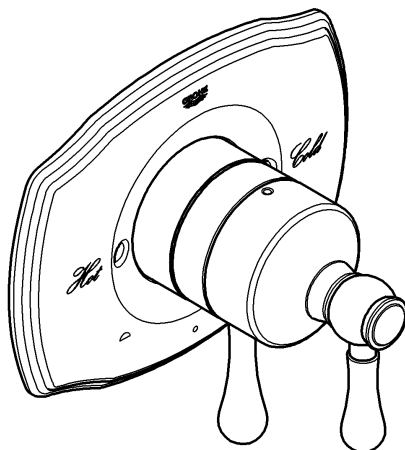

19 844



English1
Français6
Español11

Type #1
19 843

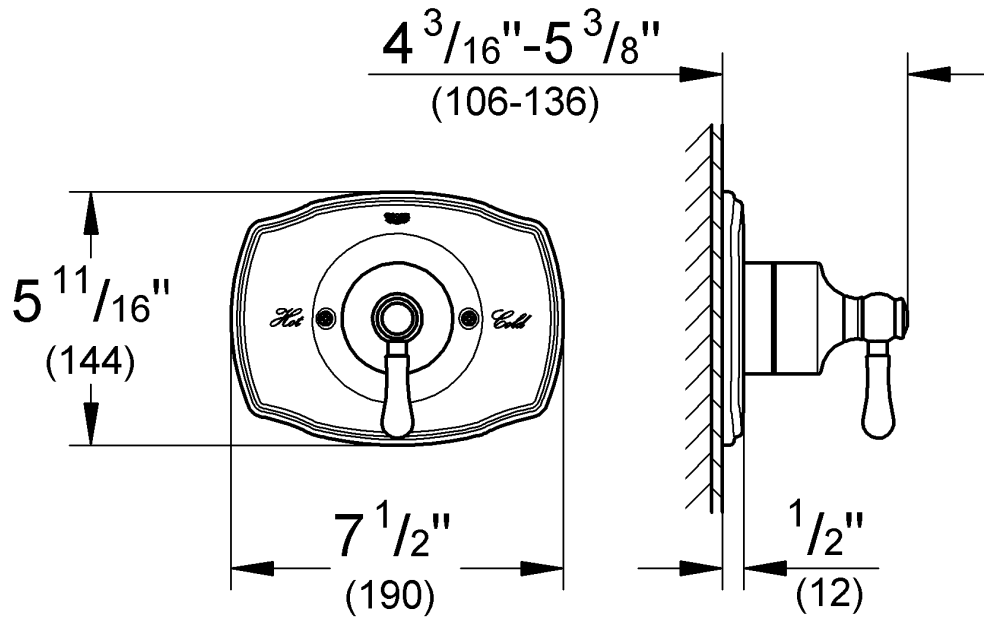

Type #2
19 844

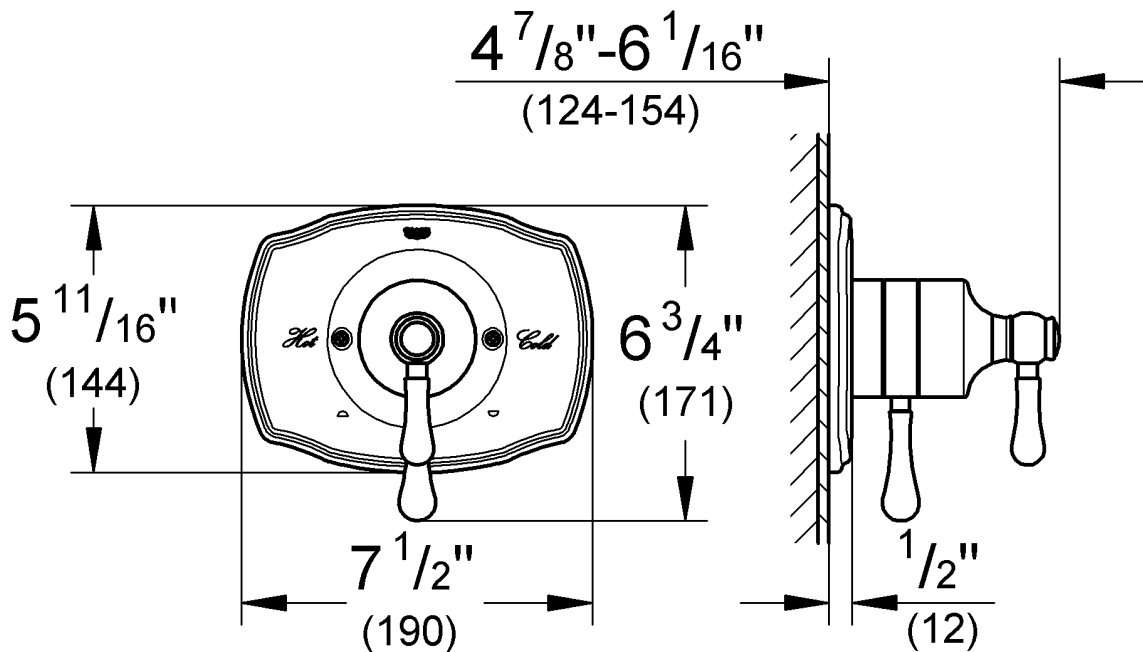

Please pass these instructions on to the end user of the fitting!
S.v.p remettre cette instruction à l'utilisateur de la robinetterie!
Entregue estas instrucciones al usuario final de la grifería!

Type #1
19 843

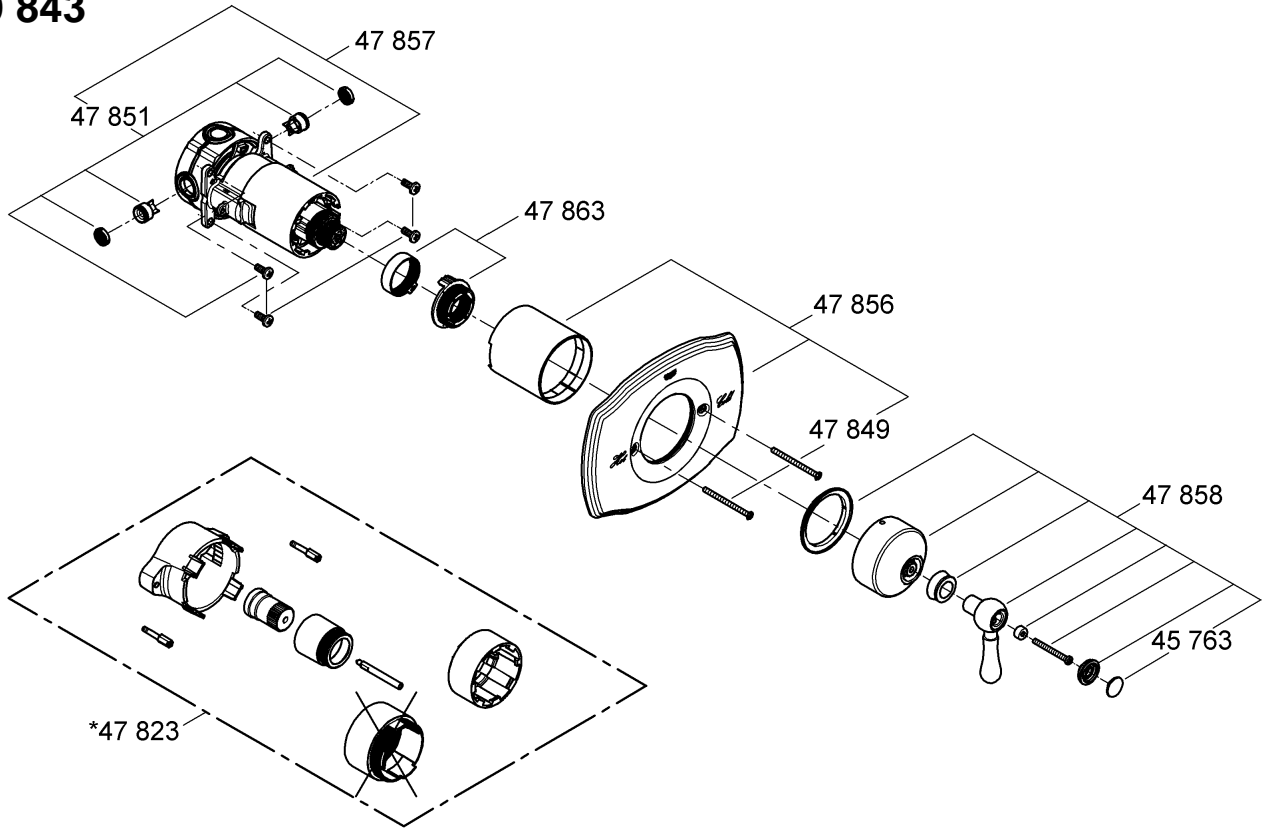

Type #2
19 844

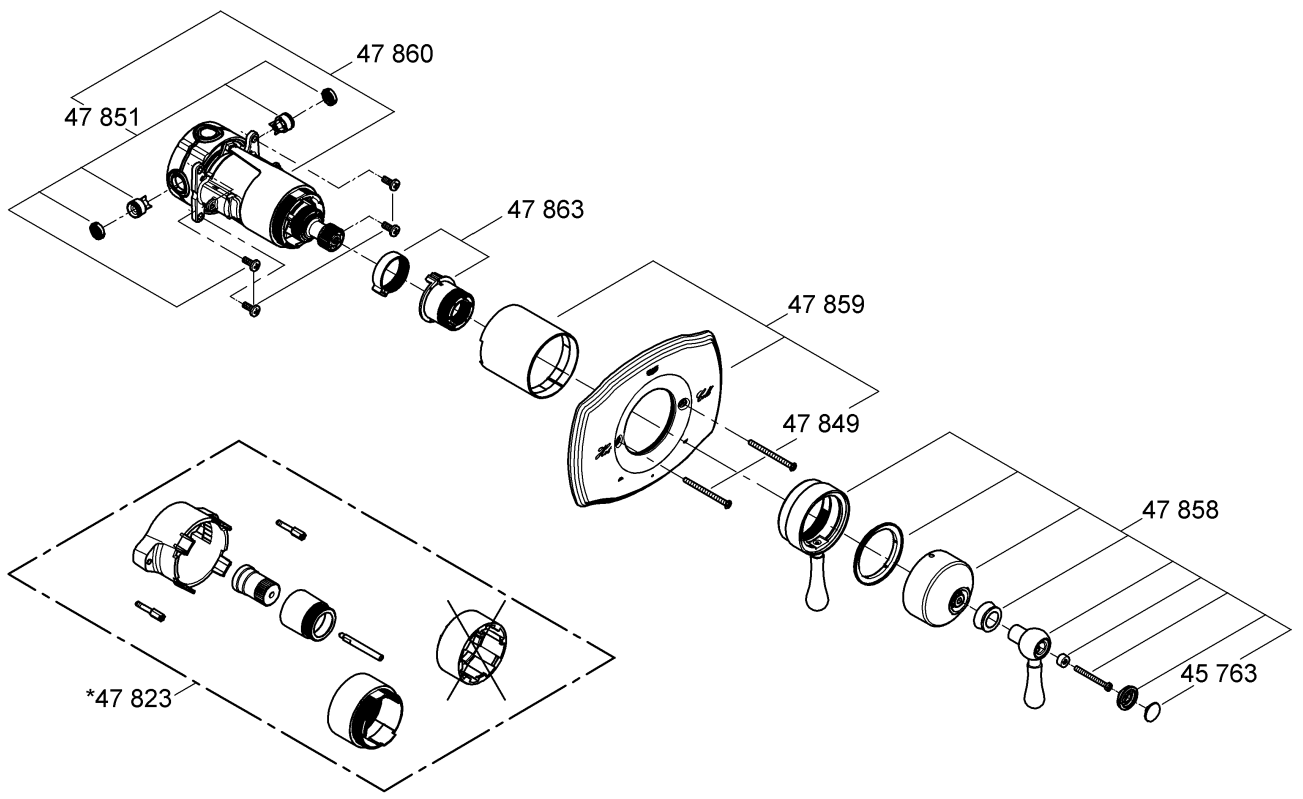

Installation options with different types of trims

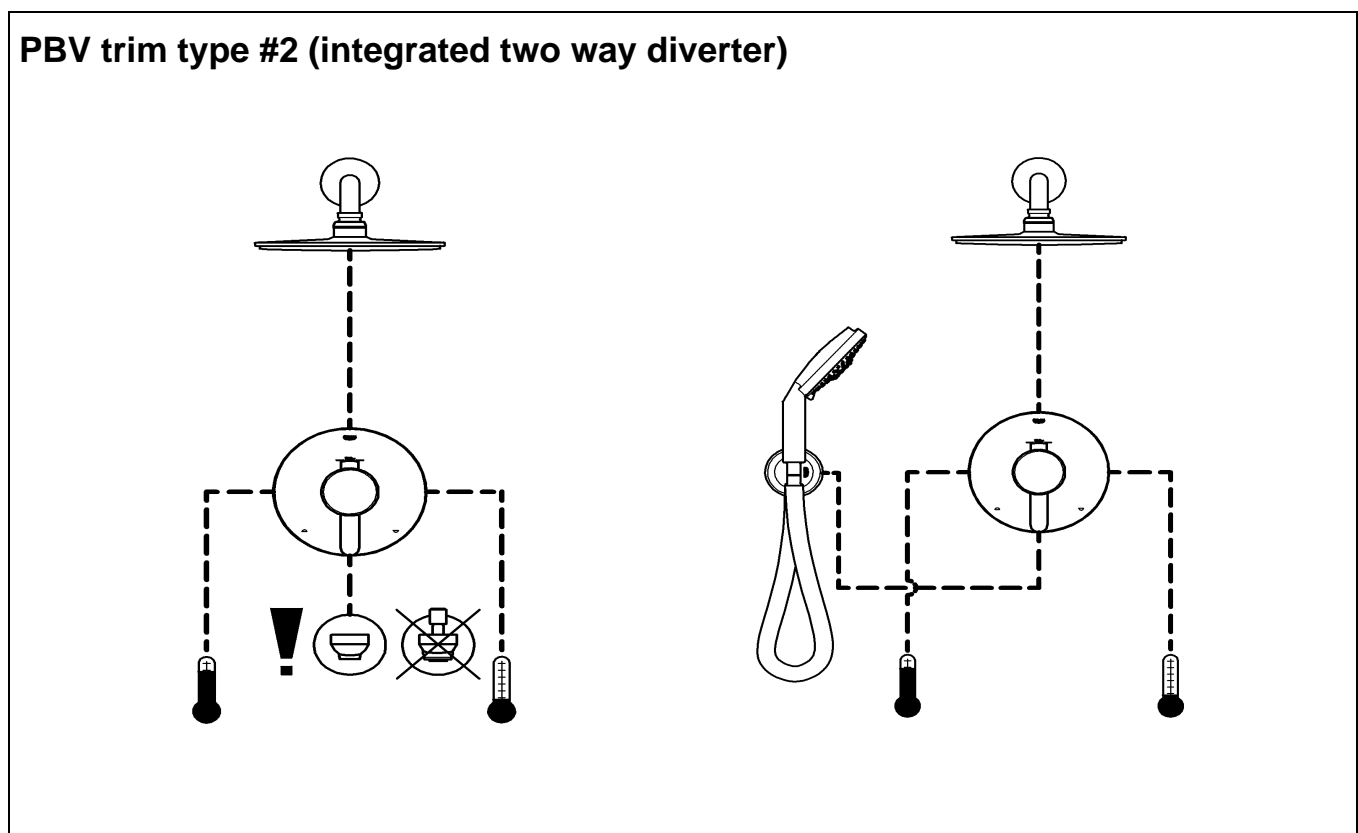
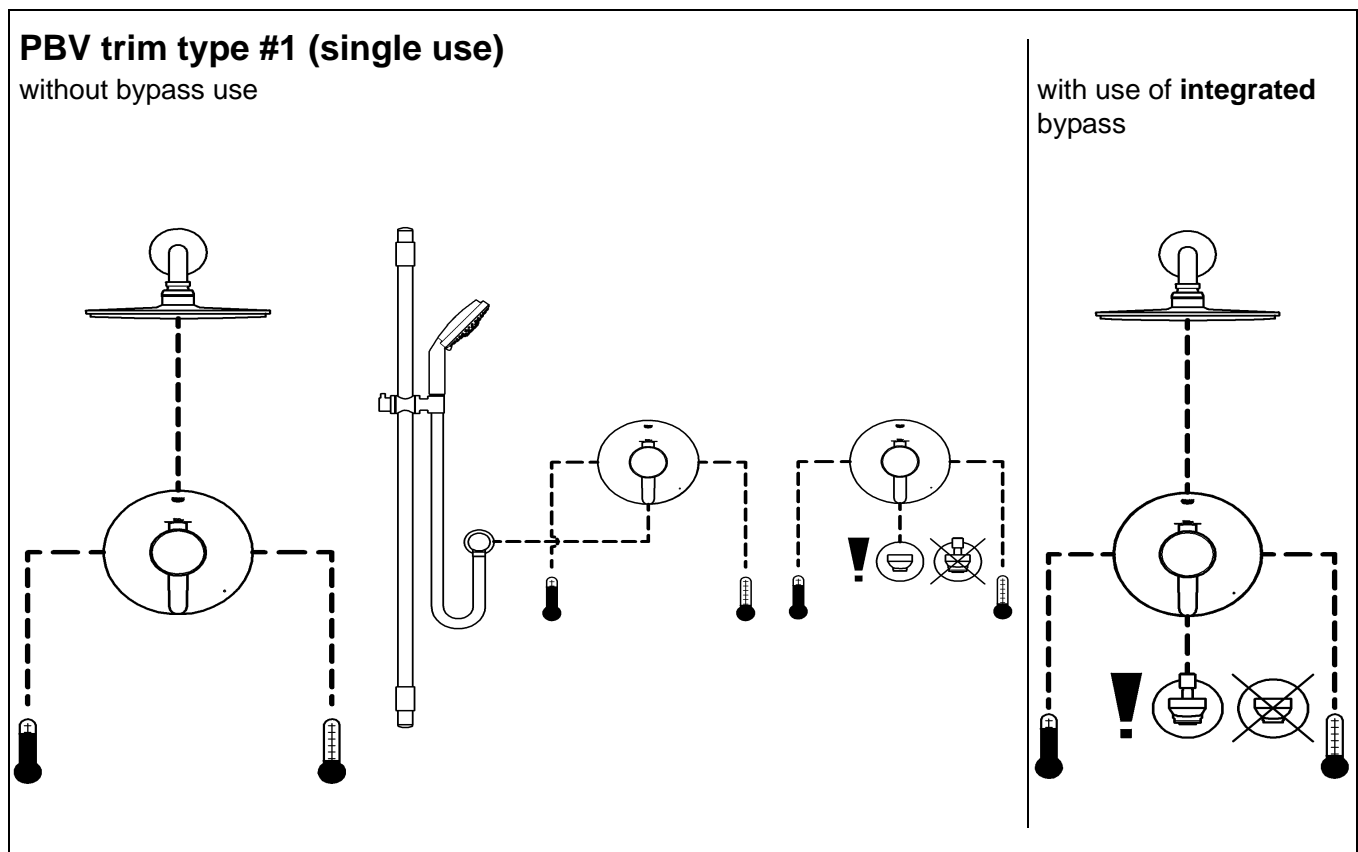

Please pass these instructions on to the end user of the faucet!

English

General Application

These Pressure Balance Valves are for use with GrohFlex™ universal rough-in valve.

Planing of piping is done at the time of the rough installation. 2 different types of PBVs are possible.

Observe the possible combinations, see Page 1.

Specification

- Concealed single handle pressure balancing valve for tub and shower
- Integral service stops
- Integral check valves prevent cross flow
- Pressure balanced diaphragm cartridge automatically adjusts to inlet pressure fluctuations
- Cartridge restricts hot water supply if the cold pressure fails, to prevent scalding
- Flow pressure:
 - min 1 bar or 14.5 psi
 - recommended 1-5 bar or 14.5 – 72.5 psi
 If greater than 5 bar or 72.5 psi, fit pressure reducing valve
- Max. operating pressure 8.5 bar or 125 psi
- Max. test pressure 34.5 bar or 500 psi

- Flow rates at 3 bar or 45 psi
 - Type #1 19 843 23 l/min or 6,1 gpm
 - Type #2 19 844 20 l/min or 5,3 gpm
- bottom outlet 11 l/min or 2,9 gpm
- top outlet 11 l/min or 2,9 gpm
- Temperature
 - max. (hot water inlet) 80 °C or 180 °F
- The handle rotation stop may be used to limit the maximum temperature. The maximum temperature will be reached when the handle is turned in a counter-clockwise direction.
- Back-to-back installation is possible by reversing the pressure balancing cartridge.
- Water connection:
 - cold - RH
 - hot - LH

General preparation

1. Cut off the excess blue box material, see fig. [1].
2. Seal the rough-in valve, see fig. [2].
3. Close the integrated service stops, see fig. [3].
4. Remove flush cap, see fig. [4].

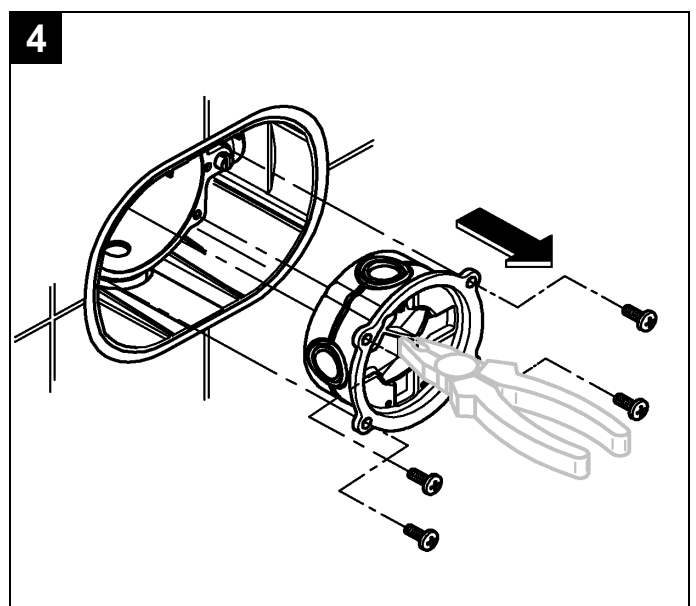
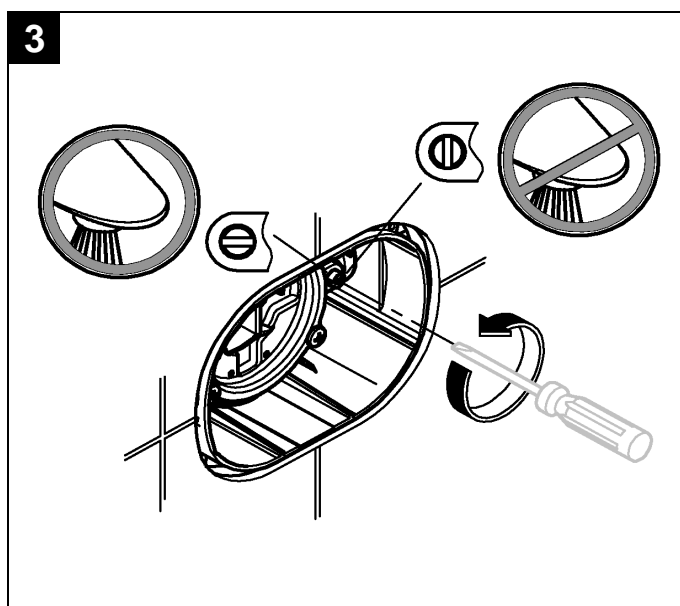
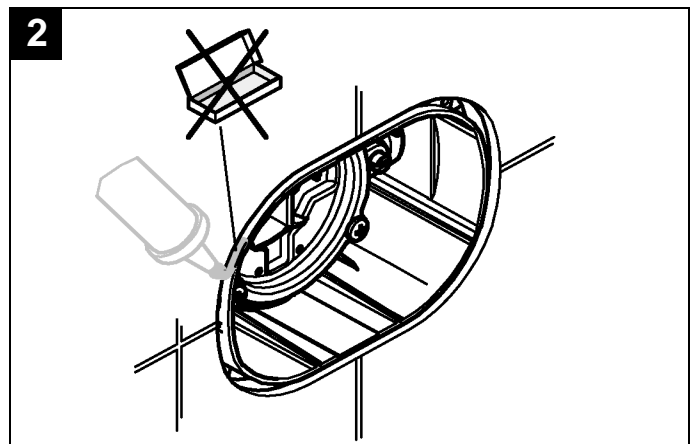
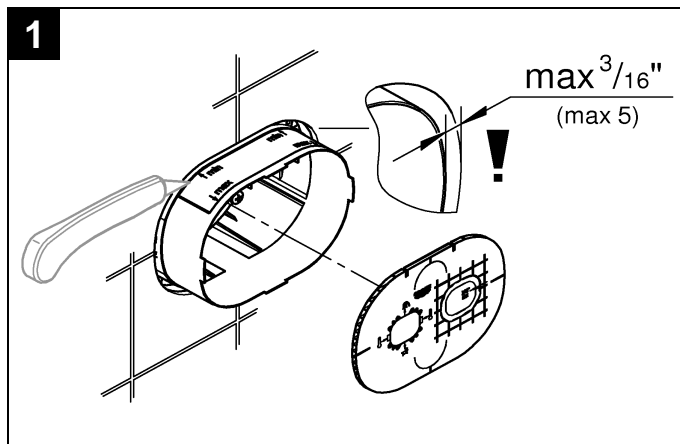

English

Installation Type #1 19 843

If **both** rough-in outlets are used, you have to install a spout **with diverter**. If only **the lower** rough-in outlet is used, you have to install a spout **without diverter**.

1. Install control unit and secure with screws, see Fig. [5].
2. Close valve by turning the adapter (A) clockwise until it stops, see Fig. [6].
3. Open the hot and cold integrated service stops.
4. For installation of handle parts, see Fig. [7].
5. While installation observe the right mounting position.

If the pressure balancing valve is installed too deep, the fitting depth can be increased by 25mm or 1" with an extension set, Part No. 47 823, see page II.

Note:

The preset maximum temperature will change if the inlet temperatures change or the setting of the water heater thermostat is altered or if the water inlet temperature is fluctuating.

Operation

Turn lever anti-clockwise:

- Open from cold to hot water flow, see Fig. [8].

The adjustable hot water limit stop (B) is factory set at a position to limit maximum outlet temperature to below the hot water supply temperature, see Fig. [7]. For installations where there is need to modify the limit temperature, remove the limit stop (B) and replace in a more clockwise position for colder water, or more counter-clockwise position for hotter water.

Observe the mounting position of stop (C).

