



# SERVICE PARTS LIST

**BULLETIN NO.**  
**54-26-2712**

SPECIFY CATALOG NO. AND SERIAL NO. WHEN ORDERING PARTS		REVISED BULLETIN 54-26-2711	DATE Aug. 2014
<b>18 Volt 1/2" Square Impact Driver</b>			
CATALOG NO.	<b>2652-20</b>	STARTING SERIAL NO.	<b>B78C</b>
		<b>SEE PAGE 3</b>	

#77 Two styles of Brush Card Assemblies See Page Two

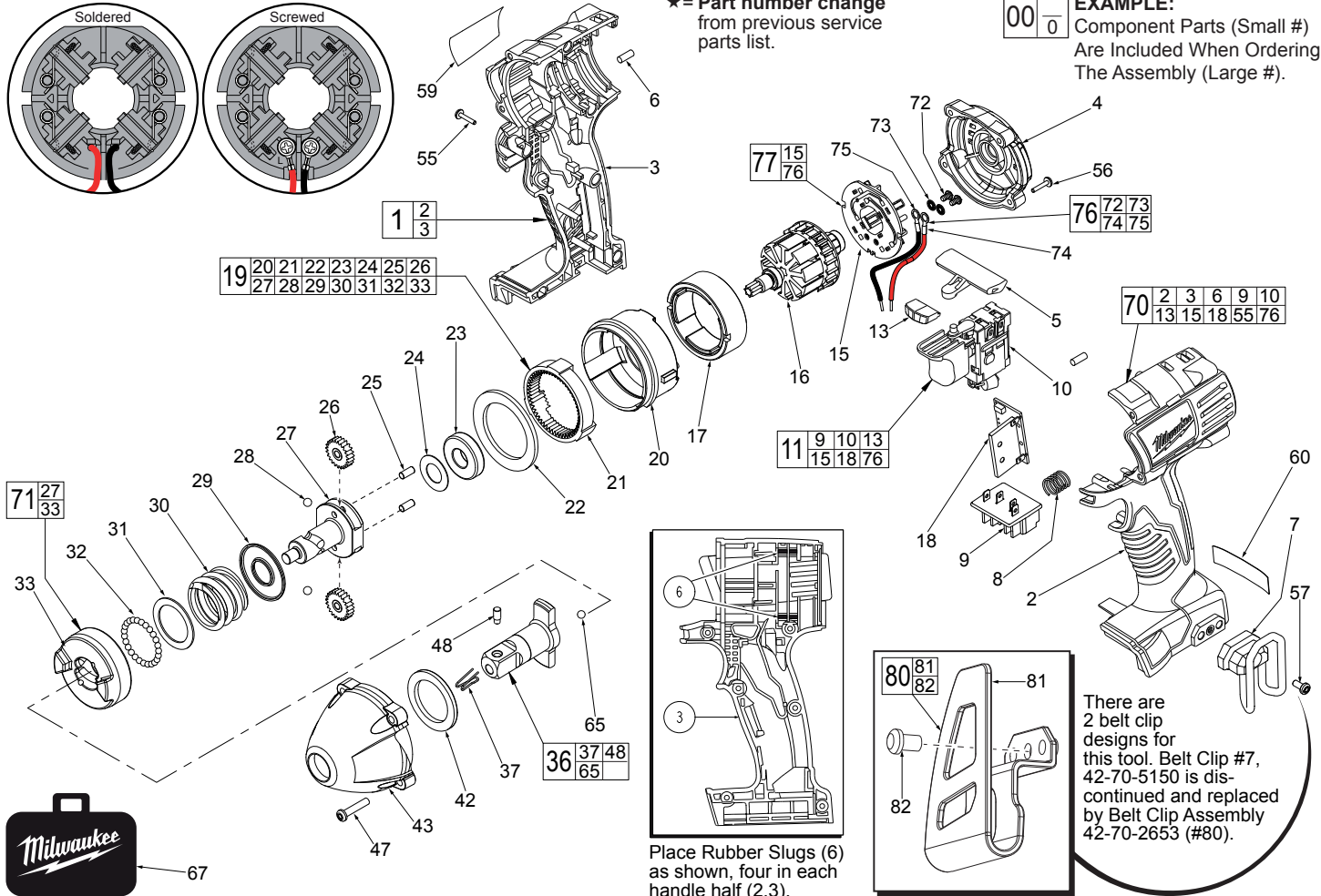
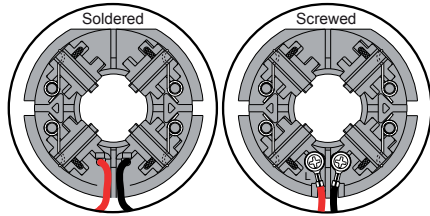

★ = Part number change from previous service parts list.

**EXAMPLE:**  
Component Parts (Small #) Are Included When Ordering The Assembly (Large #).

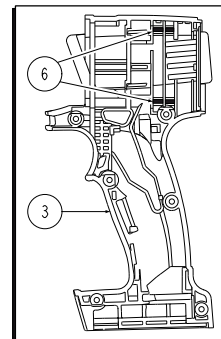

Place Rubber Slugs (6) as shown, four in each handle half (2,3).

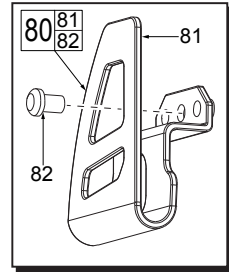

There are 2 belt clip designs for this tool. Belt Clip #7, 42-70-5150 is discontinued and replaced by Belt Clip Assembly 42-70-2653 (#80).

FIG.	PART NO.	DESCRIPTION OF PART	NO. REQ.
★ 1	31-44-2435	Handle Assembly	(1)
2	-----	Left Handle Half	(1)
3	-----	Right Handle Half	(1)
4	42-52-0062	End Cap	(1)
5	45-24-0300	Forward / Reverse Shuttle	(1)
6	45-30-0250	Rubber Slug	(8)
7	42-70-5150	Belt Hook	(1)
8	40-50-1090	Spring	(1)
9	-----	Contact Block	(1)
★ 10	23-66-2830	Switch	(1)
★ 11	23-66-1238	Switch/Brush Card Assembly	(1)
★ 13	-----	LED Assembly	(1)
★ 15	-----	Brush Card	(1)
16	16-01-3010	Service Armature Assembly	(1)
17	18-01-3010	Service Field	(1)
★ 18	-----	PCB Assembly	(1)
19	14-30-0920	Gear Box Assembly	(1)
20	-----	Rear Case	(1)
21	-----	Ring Gear	(1)
22	-----	Retaining Ring	(1)
23	-----	Ball Bearing	(1)
24	-----	Washer	(1)
25	-----	Pin	(2)
26	-----	Planet Gear	(2)
27	-----	Cam Shaft	(1)
28	-----	3/16" Steel Ball	(2)
29	-----	Washer	(1)
30	-----	Compression Spring	(1)
31	-----	Washer	(1)
32	-----	3.0mm Steel Ball	(30)
33	-----	Hammer	(1)
36	42-06-0650	1/2" Square Drive Anvil Assy. w/ Bearing	(1)

FIG.	PART NO.	DESCRIPTION OF PART	NO. REQ.
37	40-50-8320	Detent Spring	(1)
42	45-88-1317	Front Washer	(1)
43	28-50-0900	Front Case Sub-Assembly w/ Bushing	(1)
47	06-82-7010	8-18 x 24 Pan Hd. Screw	(4)
48	44-60-1170	Detent Pin	(1)
55	06-82-6350	M3 Pan Hd. T-10 Screw	(7)
56	06-82-7336	M3 Pan Hd. T-10 Screw	(4)
57	06-82-5275	6-32 x 5/16" Slit. Pan Hd. T-15 Screw	(1)
59	12-20-2650	Service Nameplate Kit	(1)
60	10-20-2695	Warning Label	(1)
65	02-02-1300	5mm Steel Ball	(1)
67	42-55-2650	Carrying Case	(1)
★ 70	23-66-1239	Switch and Housing Kit	(1)
★ 71	14-46-1710	Cam Shaft/Hammer Kit	(1)
72	05-88-0928	M3 x 5mm Pan Hd. T10 Screw	(2)
73	45-88-1980	Spring Washer	(2)
74	-----	Leadwire Assembly - Red	(1)
75	-----	Leadwire Assembly - Black	(1)
76	14-46-2395	Leadwire/Screw/Washer Kit	(1)
77	14-46-2024	Brush Card Assembly	(1)
80	42-70-2653	Belt Clip Assembly	(1)
81	-----	Belt Clip	(1)
82	-----	Belt Clip Screw	(1)

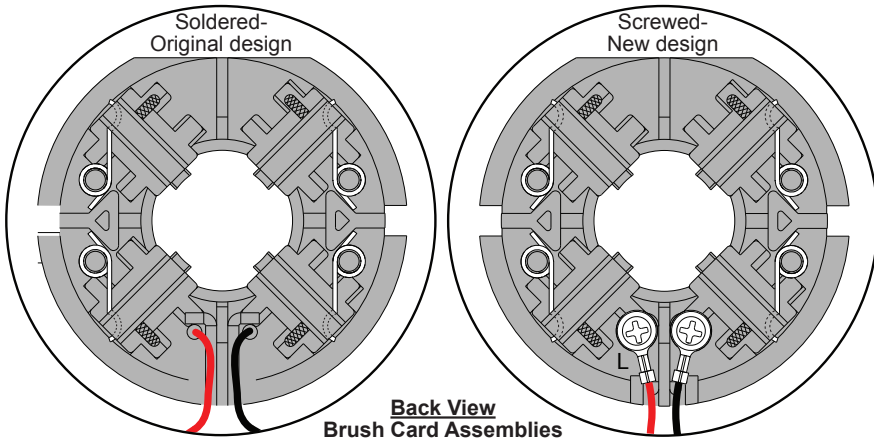

**NOTE:**  
There are two Brush Card Assembly designs.

On the original brush card design the red and black wires that go to the switch are soldered on the brush card.

On the new brush card design the red and black wires that go to the switch are secured to the brush card with spring washers and screws.

The new brush card design is **directly interchangeable** in tools that have the old brush card design.

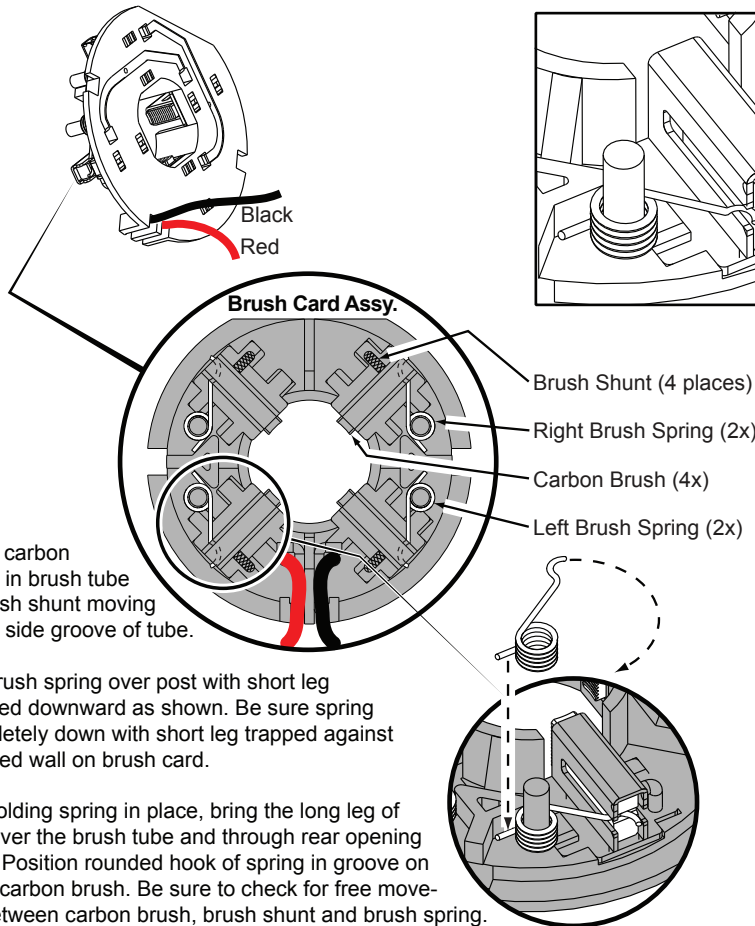

**NOTE:**  
As an aid to prevent damage to the armature commutator or the brushes when removing and installing the armature assembly, it is recommended to pull the carbon brushes partially back into the brush tube. The carbon brushes will be held in place with the brush spring moving from the rear of the brush to the side of the brush.

In the unlikely event that the spring pops off follow the instructions below.

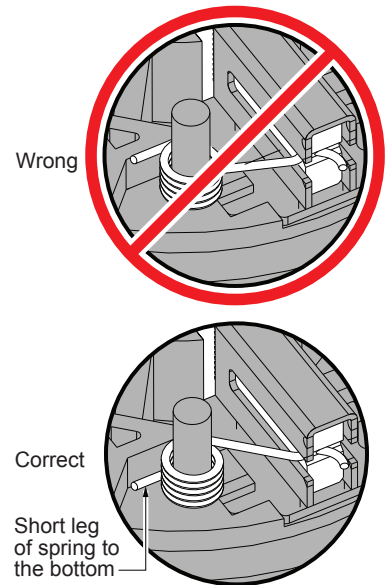

- FIG. 15,16,17** **NOTES:** See service note and illustration on the back of bulletin to aid with the removal and installation of the the Brush Card (15), Armature (16) and Field (17).
- 17** Field (17) to be positioned with side cut-outs to the front.
- 20,21** Position Ring Gear (21) with three lugs face down to interlock in the bottom of Rear Case (20).
- 20,43** Be sure to match the raised contours on the bottom of Rear Case (20) with raised contour on bottom of Front Case (43) when assembling.
- 29,30** Make sure concave side of Washer (29) faces Spring (30).
- 42,43** Tapered end of Front Washer (42) to face Front Case (43).

- FIG. 21,26** **LUBRICATION (Type 'J' Grease, No. 49-08-4220):** Lightly coat I.D. of the Ring Gear (21) and center of the two Planet Gears (26) with grease.
- 27** Place a dab of grease in the ball grooves of the Cam Shaft (27).
- 36,37** Lightly coat front washer surface of Anvil (36) with grease, place a dab in the Ball holes of Anvil and in Needle Bearing inside the Anvil.
- 43** Coat inside grooves of Bushing (inside of 43) with grease.

**NOTE:** Before attempting to remove armature or brush card assembly- Pull brush back until the brush spring slides from the back of the brush, onto the side of the brush as shown. (Do this to all four brushes). This will hold brushes out of the way for ease of servicing and will help prevent damage to the carbon brushes and the commutator of the armature.

To reinstall components, orient the Field with the cut-outs facing forward, place the Armature into the Field prior to assembling onto the Brush Card Assembly. Make sure that all brushes are returned to the proper position once Brush Card, Armature and Field are properly seated in the Left Handle Half.

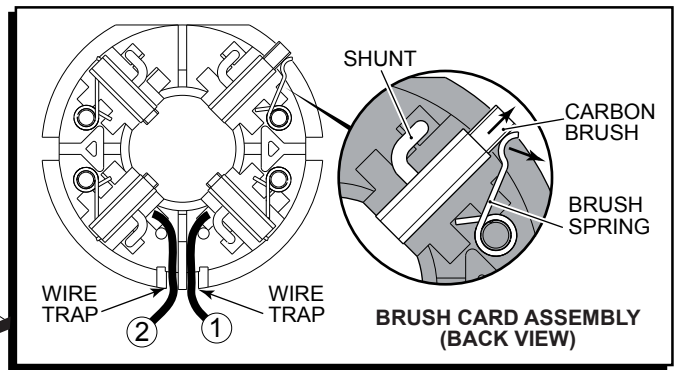

Be sure to place black wire #1 and red wire #2 firmly in the wire traps on the bottom of brush card to prevent pinching between handle halves and end cap.

Model 2650-20 shown

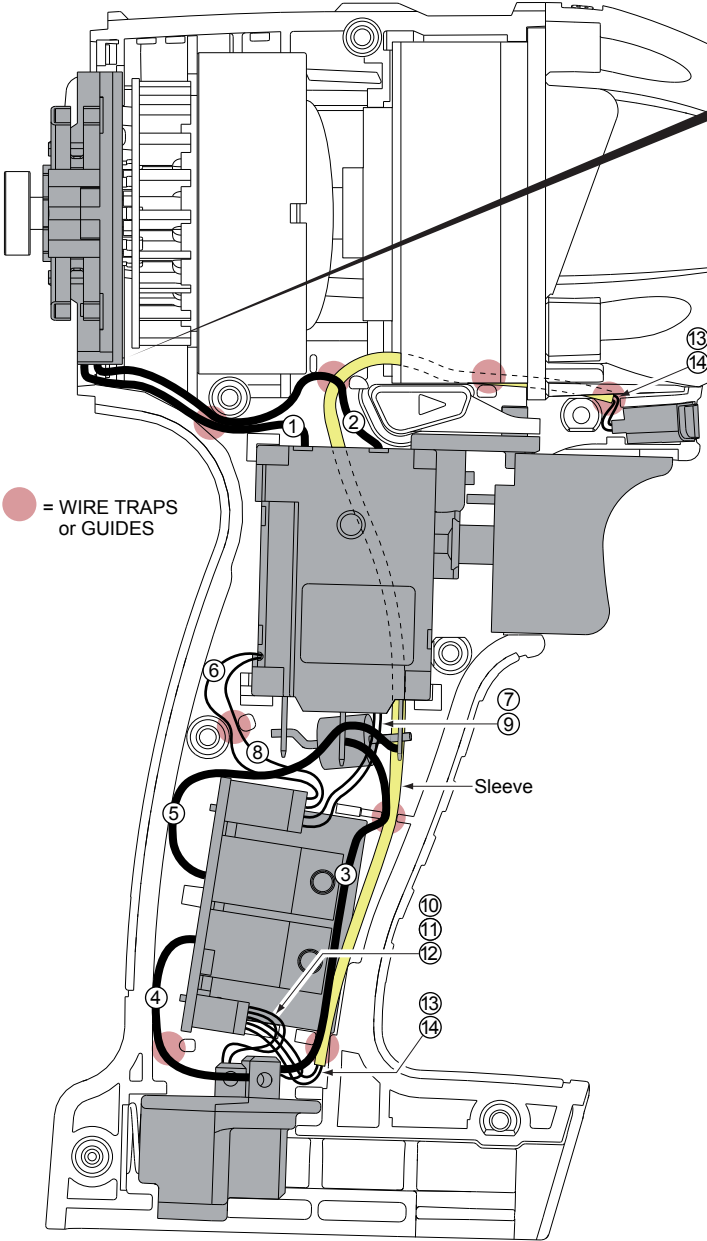

● = WIRE TRAPS or GUIDES

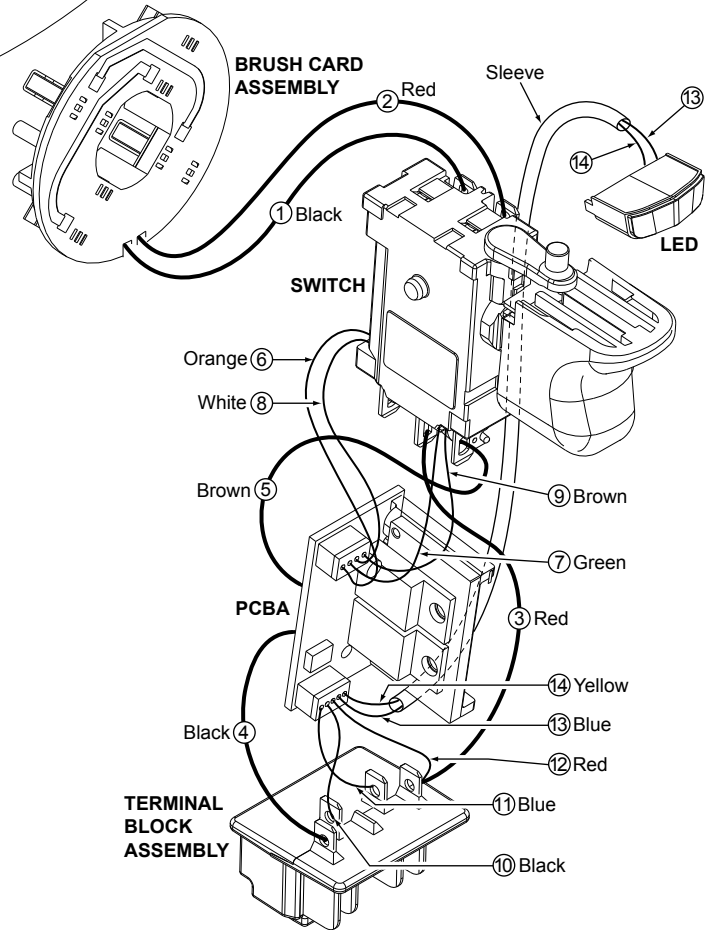

**WIRING SPECIFICATIONS**

Wire No.	Wire Color	Origin or Gauge	Length	Terminals, Connectors and 1 or 2 End Wire Preparation
1	Black	----	----	Component of Brush Card Assy. Connect to M2 on Switch.
2	Red	----	----	Component of Brush Card Assy. Connect to M1 on Switch.
3	Red	----	----	Component of Switch/Brush Card/Terminal Block Assembly.
4	Black	----	----	Component of Switch/Brush Card/Terminal Block Assembly.
5	Brown	----	----	Component of Switch/Brush Card/Terminal Block Assembly.
6	Orange	----	----	Component of Switch/Brush Card/Terminal Block Assembly.
7	Green	----	----	Component of Switch/Brush Card/Terminal Block Assembly.
8	White	----	----	Component of Switch/Brush Card/Terminal Block Assembly.
9	Brown	----	----	Component of Switch/Brush Card/Terminal Block Assembly.
10	Black	----	----	Component of Switch/Brush Card/Terminal Block Assembly.
11	Blue	----	----	Component of Switch/Brush Card/Terminal Block Assembly.
12	Red	----	----	Component of Switch/Brush Card/Terminal Block Assembly.
13	Blue	----	----	Component of Switch/Brush Card/Terminal Block Assy. (LED)
14	Yellow	----	----	Component of Switch/Brush Card/Terminal Block Assy. (LED)

AS AN AID TO REASSEMBLY, TAKE NOTICE OF WIRE ROUTING AND POSITION IN WIRE GUIDES AND TRAPS WHILE DISMANTLING TOOL.

BE CAREFUL AND AVOID PINCHING WIRES BETWEEN HANDLE HALVES WHEN ASSEMBLING.