

MODEL 6964N CEILING/WALL FAN

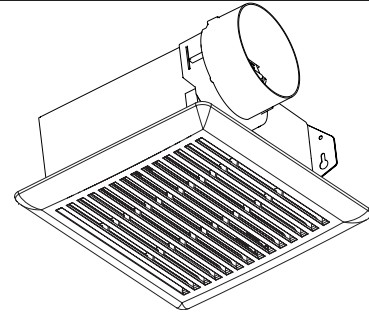

FEATURES

GRILLE:

- White polymeric – blends well with any decor
- Torsion spring grille mounting - no tools required

BLOWER:

- Plug-in, permanently lubricated motor
- Polymeric blower wheel
- Snap in/out assembly for easy cleaning - no screws to drive or drop

HOUSING:

- Compact, 25 gage galvanized steel, attaches easily to wall or ceiling joists. Cannot be installed in walls using 2" x 4" joists
- Double strength mounting flanges with keyhole slots
- Removable wiring cover - make connections away from tight corners
- No electrical knockout to remove
- Polymeric duct fitting with tapered sleeve for easy, positive duct connection
- Quiet polymeric damper prevents cold backdrafts - no metallic clatter
- U.L. Listed for use over bathtubs and showers when connected to a GFCI protected branch circuit (ceiling mount only).

CONTROLS (purchase separately):

- Refer to the NuTone ventilation fan catalog for a complete line of accessories to effectively adapt this fan to your construction requirements.

Available only as follows:

- **MODEL 6884H Project Housing Pack (18 per carton) combined with MODEL 696RNB Project Finish Pack (6 per carton).**

TYPICAL SPECIFICATION

Fan shall be NuTone Model 6964N.

Fan shall have galvanized steel housing with double-strength mounting flanges. It shall be ducted vertically (horizontally) to a roof cap (wall cap).

Blower assembly shall be removable and permanently lubricated.

Air delivery shall be no less than 50 CFM and sound level no greater than 4.0 sones. All air and sound ratings shall be certified by HVI.

Non-metallic damper/duct connector shall be included.

Fan shall be U.L. Listed for use over bathtubs and showers when connected to a GFCI protected branch circuit.



Broan Hartford, Wisconsin www.broan-nutone.com 888-336-3948

REFERENCE	QTY.	REMARKS	Project
			Location
			Architect
			Engineer
			Contractor
			Submitted by Date

PERFORMANCE RATINGS

Model 6964N CEILING/WALL FAN

HVI PERFORMANCE

Airflow (CFM)	Sound (Sones)
50	4.0



HVI-2100 CERTIFIED RATINGS comply with new testing technologies and procedures prescribed by the Home Ventilating Institute, for off-the-shelf products, as they are available to consumers. Product performance is rated at 0.1 in. static pressure, based on tests conducted in a state-of-the-art test laboratory. Sones are a measure of humanly-perceived loudness, based on laboratory measurements.

ELECTRICAL

Volts	Hz	Amps
120	60	0.9



AIR FLOW PERFORMANCE

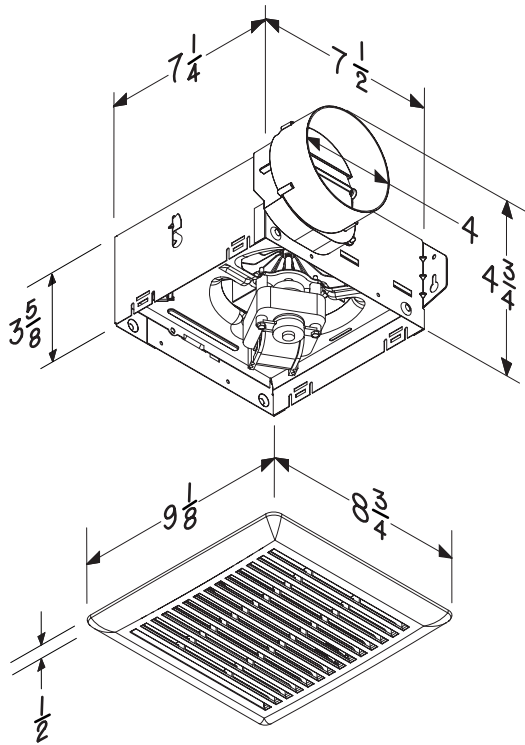
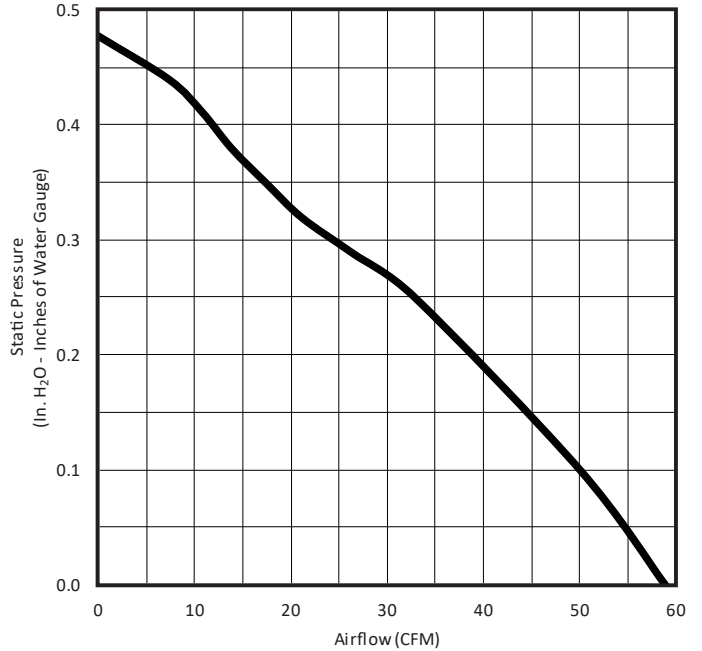

NOTE: Dimensions shown are in inches.