

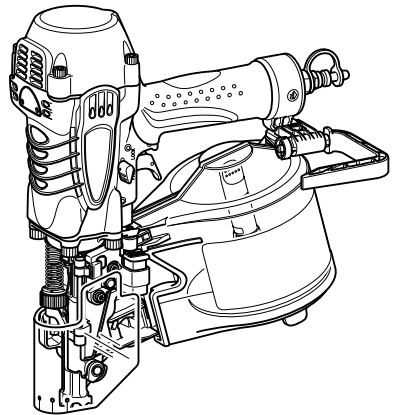

INSTRUCTION MANUAL  
MANUEL D'INSTRUCTION  
MANUAL DE INSTRUCCIONES

# Construction Coil Nailer Pistolet Clouer Clavadora Neumática de Carrete

AN930H



013439

**IMPORTANT:** Read Before Using.  
**IMPORTANT:** Lire avant usage.  
**IMPORTANTE:** Leer antes de usar.

## ENGLISH (Original instructions)

# SPECIFICATIONS

Model	AN930H
Air pressure	170 - 320 PSIG (1.18 - 2.26 MPa)
Nail length	Wire-collated coil nail 45 mm (1-3/4") - 90 mm (3-1/2") Sheet-collated coil nail 45 mm (1-3/4") - 75 mm (3")
Nail capacity	Wire-collated coil nail 120 pcs ~ 300 pcs Sheet-collated coil nail 200 pcs
Min. hose diameter	4.0 mm (5/32")
Dimensions (L X W X H)	286 mm (11-1/4") X 128 mm (5-1/32") X 330 mm (13")
Net weight	2.6 kg (5.7 lbs)

- Due to our continuing program of research and development, the specifications herein are subject to change without notice.
- Specifications may differ from country to country.
- Weight according to EPTA-Procedure 01/2003

USB092-2

## IMPORTANT SAFETY INSTRUCTIONS

**WARNING: WHEN USING THIS TOOL, BASIC SAFETY PRECAUTIONS SHOULD ALWAYS BE FOLLOWED TO REDUCE THE RISK OF PERSONAL INJURY, INCLUDING THE FOLLOWING:**

### READ ALL INSTRUCTIONS.

1. For personal safety and proper operation and maintenance of the tool, read this instruction manual carefully before using the tool.
2. Always wear safety glasses to protect your eyes from dust or nail injury. The safety glasses should conform with the requirements of ANSI Z87.1.

#### WARNING:

It is an employer's responsibility to enforce the use of safety eye protection equipment by the tool operators and by other persons in the immediate working area.

3. Wear hearing protection to protect your ears against exhaust noise and head protection. Also wear light but not loose clothing. Sleeves should be buttoned or rolled up. No necktie should be worn.
4. Rushing the job or forcing the tool is dangerous. Handle the tool carefully. Do not operate when under the influence of alcohol, drugs or the like.
5. General Tool Handling Guidelines:
  - (1) Always assume that the tool contains fasteners.
  - (2) Do not point the tool toward yourself or anyone whether it contains fasteners or not.

- (3) Do not actuate the tool unless the tool is placed firmly against the workpiece.
- (4) Respect the tool as a working implement.
- (5) No horseplay.
- (6) Do not hold or carry the tool with a finger on the trigger.
- (7) Do not load the tool with fasteners when any one of the operating controls is activated.
- (8) Do not operate the tool with any power source other than that specified in the tool operating/safety instructions.
6. An improperly functioning tool must not be used.
7. Sparks sometimes fly when the tool is used. Do not use the tool near volatile, flammable materials such as gasoline, thinner, paint, gas, adhesives, etc.; they will ignite and explode, causing serious injury.
8. The area should be sufficiently illuminated to assure safe operations. The area should be clear and litter-free. Be especially careful to maintain good footing and balance.
9. Only those involved in the work should be in the vicinity. Children especially must be kept away at all times.
10. There may be local regulations concerning noise which must be complied with by keeping noise levels within prescribed limits. In certain cases, shutters should be used to contain noise.
11. Do not play with the contact element: it prevents accidental discharge, so it must be kept on and not removed. Securing the trigger in the ON position is also very dangerous. Never attempt to fasten the trigger. Do not operate a tool if any portion of the tool operating controls is inoperable, disconnected, altered, or not working properly.

12. Operate the tool within the specified air pressure on the tool label for safety and longer tool life. Do not exceed the recommended max. operating pressure. The tool should not be connected to a source whose pressure potentially exceeds 480 PSIG (3.39 MPa).
13. Never use the tool with other than compressed air. If bottled gas (carbon dioxide, oxygen, nitrogen, hydrogen, air, etc.) or combustible gas (hydrogen, propane, acetylene, etc.) is used as a power source for this tool, the tool will explode and cause serious injury.
14. Always check the tool for its overall condition and loose screws before operation. Tighten as required.
15. Make sure all safety systems are in working order before operation. The tool must not operate if only the trigger is pulled or if only the contact element is pressed against the wood. It must work only when both actions are performed. Test for possible faulty operation with nails unloaded and the contact element in fully pulled position.
16. Check walls, ceilings, floors, roofing and the like carefully to avoid possible electrical shock, gas leakage, explosions, etc. caused by striking live wires, conduits or gas pipes.
17. Use only nails specified in this manual. The use of any other nails may cause malfunction of the tool.
18. Do not permit those uninstructed to use the tool.
19. Make sure no one is nearby before nailing. Never attempt to nail from both the inside and outside at the same time. Nails may rip through and/or fly off, presenting a grave danger.
20. Watch your footing and maintain your balance with the tool. Make sure there is no one below when working in high locations, and secure the air hose to prevent danger if there is sudden jerking or catching.
21. On rooftops and other high locations, nail as you move forward. It is easy to lose your footing if you nail while inching backward. When nailing against perpendicular surface, nail from the top to the bottom. You can perform nailing operations with less fatigue by doing so.
22. A nail will be bent or the tool can become jammed if you mistakenly nail on top of another nail or strike a knot in the wood. The nail may be thrown and hit someone, or the tool itself can react dangerously. Place the nails with care.
23. Do not leave the loaded tool or the air compressor under pressure for a long time out in the sun. Be sure that dust, sand, chips and foreign matter will not enter the tool in the place where you leave it setting.
24. Do not point the ejection port at anyone in the vicinity. Keep hands and feet away from the ejection port area.
25. When the air hose is connected, do not carry the tool with your finger on the trigger or hand it to someone in this condition. Accidental firing can be extremely dangerous.
26. Handle the tool carefully, as there is high pressure inside the tool that can be dangerous if a crack is caused by rough handling (dropping or striking). Do not attempt to carve or engrave on the tool.
27. Stop nailing operations immediately if you notice something wrong or out of the ordinary with the tool.
28. Always disconnect the air hose and remove all of the nails:
  - When unattended.
  - Before performing any maintenance or repair.
  - Before cleaning a jam.
  - Before moving the tool to a new location.
29. Perform cleaning and maintenance right after finishing the job. Keep the tool in tip-top condition. Lubricate moving parts to prevent rusting and minimize friction-related wear. Wipe off all dust from the parts.
30. Do not modify tool without authorization from Makita.
31. Do not attempt to keep the trigger or contact element depressed with tape or wire. Death or serious injury may occur.
32. Always check contact element as instructed in this manual. Nails may be driven accidentally if the safety mechanism is not working correctly.
33. Ask Makita's Authorized service centers for periodical inspection of the tool.
34. To maintain product SAFETY and RELIABILITY, maintenance and repairs should be performed by Makita Authorized or Factory Service Centers, always using Makita replacement parts.

## SAVE THESE INSTRUCTIONS.

### **WARNING:**

MISUSE or failure to follow the safety rules stated in this instruction manual may cause serious personal injury.

## Symbols

The followings show the symbols used for tool.



- Read and understand tool labels and manual.



- Operators and others in work area must wear safety glasses with side shields.



- Keep fingers away from trigger when not driving fasteners to avoid accidental firing.

## INSTALLATION

### Selecting compressor

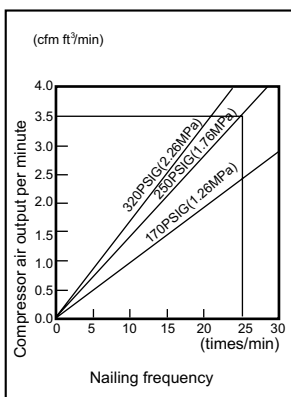

013552

The air compressor must comply with the requirements of ANSI B19.3.

Select a compressor that has ample pressure and air output to assure cost-efficient operation. The graph shows the relation between nailing frequency, applicable pressure and compressor air output.

Thus, for example, if nailing takes place at a rate of approximately 25 times per minute at a compression of 250PSIG (1.76 MPa), a compressor with an air output over 3.5 cfm (approximately 100 liters/minute) is required.

Pressure regulators must be used to limit air pressure to the rated pressure of the tool where air supply pressure exceeds the tool's rated pressure. Failure to do so may result in serious injury to tool operator or persons in the vicinity.

### Selecting air hose

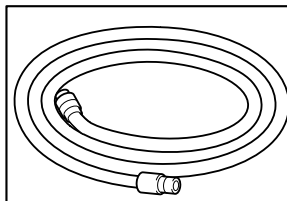

004294

Use a high pressure resistant air hose.

Use an air hose as large and as short as possible to assure continuous, efficient nailing operation.

#### ⚠CAUTION:

- Low air output of the compressor, or a long or smaller diameter air hose in relation to the nailing frequency may cause a decrease in the driving capability of the tool.

### Lubrication

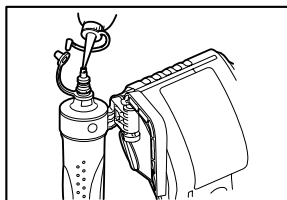

013458

Oil the tool with pneumatic tool oil by placing two or three drops into the air fitting. This should be done before and after use. For proper lubrication, the tool must be fired a couple of times after pneumatic tool oil is introduced.

## FUNCTIONAL DESCRIPTION

### ⚠CAUTION:

- Always disconnect the air hose before adjusting or checking function on the tool.

### Adjusting the nailing depth

### ⚠CAUTION:

- Always disconnect the hose before adjusting the depth of nailing.

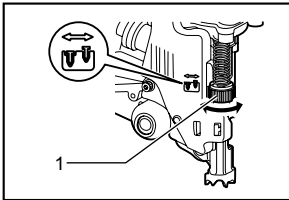

1. Adjuster

013449

This tool has the adjuster of the nailing depth. To modulate the nailing depth, turn the adjuster to the proper depth.

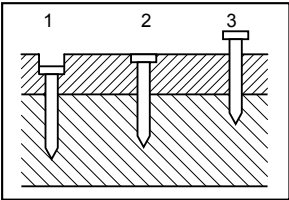

1. Too deep  
2. Flush  
3. Too shallow

009180

The adjustable range is 10 mm (3/8"). (One full turn allows 1.25 mm (1/16") adjustment.)

### Hook

### ⚠CAUTION:

- Always disconnect the hose when hanging the tool using the hook.
- Never hang the tool on a waist belt or like. Dangerous accidental firing may result.

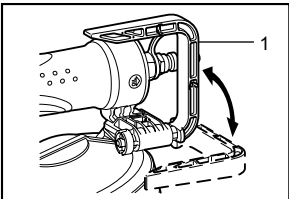

1. Hook

013450

The hook is convenient for hanging the tool temporarily. This hook can be installed on either side of the tool. Furthermore, this hook can be turned by hand to the desired angle of the tool.

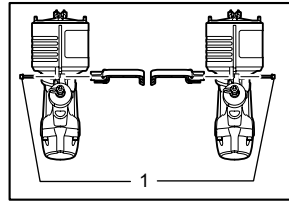

1. Screw

013451

When changing the installation position, remove the screw with a screwdriver. Install the hook on another side for installation and then secure it with the screw.

### Use the nose adapter

### ⚠CAUTION:

- Always disconnect the hose before installing or removing the nose adapter.
- If you like to protect the surface of workpiece, attach the nose adapter of contact element.

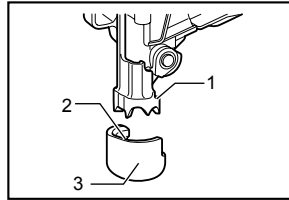

1. Hole  
2. Protrusion  
3. Nose adapter

013453

When nailing workpieces with easily-marred surfaces, use the nose adapter.

To detach the nose adapter from its housing base, turn the nose adapter in the direction of the arrow.

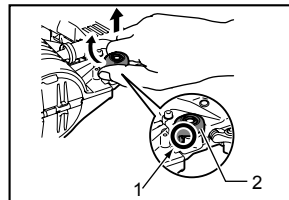

1. Push  
2. Nose adapter

013452

To attach the nose adapter to the contact element, press it onto the contact element until the protrusion in two places inside the nose adapter fit in two holes in the contact element.

## ASSEMBLY

### ⚠CAUTION:

- Always disconnect the air hose before loading the nailer.

### Loading the nailer

### ⚠CAUTION:

- Make sure that the coil support plate is set to the correct step for used nails.

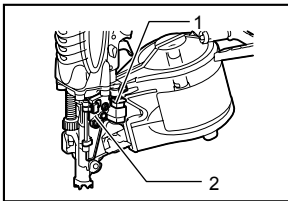

- Latch lever
- Door

013444

Disconnect the air hose from the tool. Select nails suitable for your work. Depress the latch lever and open the door and magazine cap.

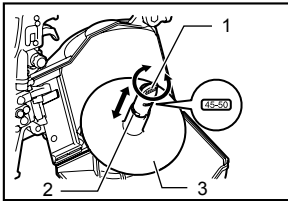

- Adjust shaft
- Arrow
- Change plate

013445

Turn the adjust shaft so that the arrow with nail size indicated on the change plate will point to the corresponding graduation increment marked on the magazine. If the tool is operated with the change plate set to the wrong step, poor nail feed or malfunction of the tool may result.

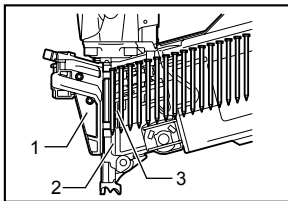

- Door
- Feed Claw
- Driver channel

013446

Place the nail coil over the change plate. Uncoil enough nails to reach the nail guide. Place the first nail in the feeder and the second nail in the feed claw. Place other uncoiled nails on feeder body. After checking to see that the nail coil is set properly in the magazine, close the

magazine cap slowly and then close the door until it locks.

### Connecting air hose

Slip the air socket of the air hose onto the air fitting on the nailer. Be sure that the air socket locks firmly into position when installed onto the air fitting. A hose coupling must be installed on or near the tool in such a way that the pressure reservoir will discharge at the time the air supply coupling is disconnected.

### Changing the trigger for intermittent nailing

### ⚠CAUTION:

- Always disconnect the air hose and unload the tool with nails before replacing the trigger.
- After the trigger replacement, always check the tool operates properly before actual work. Do not load the tool with any nails before checking the function to avoid unexpected nailing.

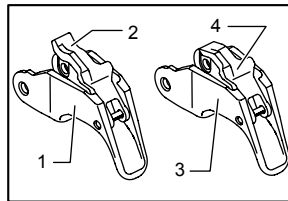

- Trigger for continuous nailing
- Silver part
- Trigger for intermittent nailing
- Black part

013502

The trigger for continuous nailing is factory-installed. To change the nailing mode to intermittent nailing, replace the switch trigger with the one for intermittent nailing.

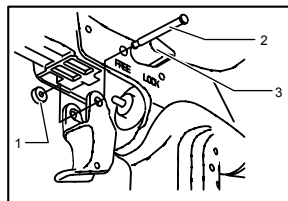

- Urethane washer
- Pin
- Lock lever

013551

- Turn the lock lever to the "LOCK" position.
- Push the pin securing the trigger from the urethane washer side, and then remove the urethane washer by fingers or flathead screwdriver and so on. Pull the pin and remove it from the hole in the housing.
- Set the trigger assembly for intermittent nailing. Turn the hinged part inward the trigger, and then set the part to contact the rod of the valve in the housing.
- Insert the pin to the hole and then secure it by urethane washer.
- Connect the air hose, and then check whether the tool operates properly. Refer to the section "Changing intermittent nailing mode".

If the tool does not actuate properly, disconnect the air hose, and then reassemble the trigger according to 1-4 shown above.

**NOTE:**

To set back to continuous nailing, follow the procedures for changing the trigger above.

**OPERATION**

**⚠ CAUTION:**

- Make sure all safety systems are in working order before operation.
- When not operating the tool, always lock the trigger by turning the change lever to the LOCK position.
- Make sure that the trigger is locked when the change lever is set to the LOCK position.

**Checking continuous nailing mode**

- The tool must not operate only by connecting the air hose.

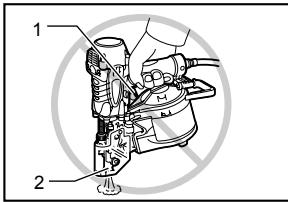

1. Trigger
2. Contact element

013440

- The tool must not operate only by pulling the trigger.

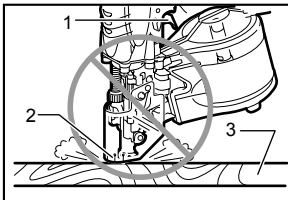

1. Trigger
2. Contact element
3. Workpiece

013503

- The tool must not operate only by placing the contact element against the work piece without pulling the trigger.

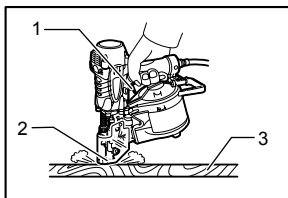

1. Trigger
2. Contact element
3. Workpiece

013489

- The tool should operate properly when pulling the trigger first and then place the contact element against the work piece.

**Checking intermittent nailing mode**

- The tool must not operate only by connecting the air hose.
- The tool must not operate only by pulling the trigger.
- The tool must not operate only by placing the contact element against the work piece without pulling the trigger.

**NOTE:**

- The operating conditions shown above are the same as the operating conditions mentioned in "checking continuous nailing mode".

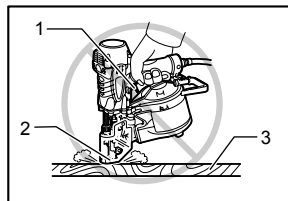

1. Trigger
2. Contact element
3. Workpiece

013441

- The tool must not operate when pulling the trigger first and then placing the contact element against the work piece.

**Nailing method**

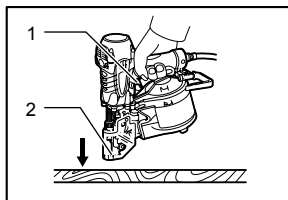

1. Pull the trigger
2. Place the contact element against workpiece.

013537

1. To drive a nail, you may pull the trigger first and then place the contact element against the workpiece, or

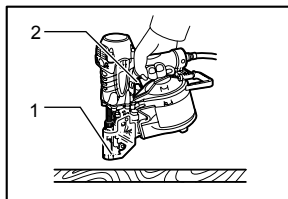

1. Place first the contact element against workpiece.
2. Pull the trigger

013538

2. Place the contact element against the workpiece and pull the trigger.
  - No. (1) method is for continuous nailing.
  - No. (2) method is for intermittent nailing, when you wish to drive a nail carefully and very accurately.

**⚠CAUTION:**

- However when the tool is set to the "Intermittent Nailing" mode, WITH THE TRIGGER HELD IN A HALF-PULLED POSITION, an unexpected nailing could occur, if contact element is allowed to re-contact against the workpiece or the other surface under the influence of recoil. In order to avoid this unexpected nailing, perform as follows:
  - A. Do not place the contact element against the workpiece with excessive force.
  - B. Pull the trigger fully and hold it on for 1-2 seconds after nailing.

To prevent the trigger from being accidentally pulled, a lock-off button is provided.

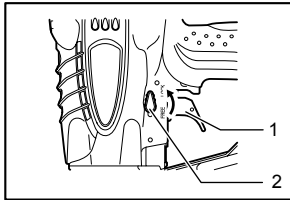

1. Trigger
2. Lock lever

013447

To lock the trigger, turn the lock lever to the "LOCK" position.

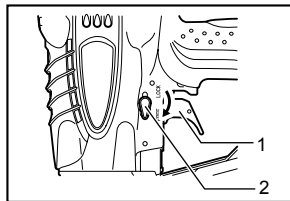

1. Trigger
2. Lock lever

013448

To start the tool, turn the lock lever to the "FREE" position.

**Nailing of steel plate**

**⚠WARNING:**

- Use 3.2 mm (1/8") or less steel for C-shaped one. The tool will bounce severely and a nail struck back, causing serious injuries.
- Use hardened nails only for steel plate. Using other purposed nails may cause serious injuries.
- When nailing, hold the tool so that it stands upright to the driving surface.

Slanted nailing may cause nails to strike back, causing serious injuries.

- Do not use for fastening a corrugated plate or the C-shaped steel directly. It may cause nails to strike back, causing serious injuries.
- Do not use the tool for nailing on ceiling or roof. Choose and use nails more than 10 mm (3/8") longer than total thickness of all workpiece to be fastened by referring to the table below.

Material thickness	C-shaped steel	Nail length
14 - 35 mm (1/2" - 1-3/8")	1.6 - 3.2 mm (1/16" - 1/8")	45 mm(1-3/4")
15 - 40 mm (5/8" - 1-5/8")		50 mm(2")

013618

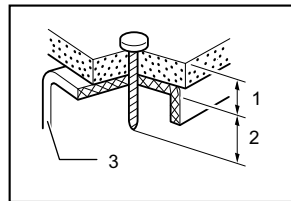

1. Thickness of workpiece
2. 10 mm (3/8") or more
3. C-shaped steel (Thickness 1.6 mm (1/16") - 3.0 mm (1/8"))

013617

**⚠CAUTION:**

- Depending on the hardness and total thickness of all workpiece in combination to be fastened, enough fastening may not be obtained. Nailing on steel plate to excessive depth may extremely reduce the fastening force. Before nailing, adjust the nailing depth properly.
- In the nailing on the steel plate, the driver may be clogged due to susceptibility to wear. When it is worn, sharpen it or replace it with a new one.

**Nailing of concrete**

**⚠WARNING:**

- Use hardened nails only for concrete. Using other purposed nails may cause serious injuries. Do not nail directly on the concrete or do not use to fasten directly the steel plate to the concrete. Failure to do so may cause concrete fragments to fly off or nails to strike back, causing serious injuries.
- When nailing, hold the tool so that it stands upright to the driving surface. Slanted nailing may cause concrete fragments to fly off or nails to strike back, causing serious injuries.
- Do not use on the surface that objects hang from, such as area where hangers for sewer pipe, dust pipe etc. are set up



Choose and use nails so that the penetration amount into concrete ranges 10 mm (3/8") - 15 mm (5/8") by referring to the table below.

Wood thickness	Nail length	Concrete range
30 mm(1-3/16")	45 mm(1-3/4")	10 mm(3/8") -15 mm(5/8")
35 mm(1-3/8")	50 mm(2")	10 mm(3/8") -15 mm(5/8")
50 mm(2")	65 mm(2-1/2")	10 mm(3/8") -15 mm(5/8")

013616

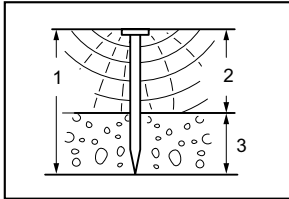

013615

**CAUTION:**

- Use this tool only for soft concrete built up not so long before. Using on the hard concrete may cause nail bending or nailing to insufficient depth.
- When the penetration amount into concrete comes to more than 15 mm, nailing to the sufficient length may not be obtained.

**Cutting off the sheet**

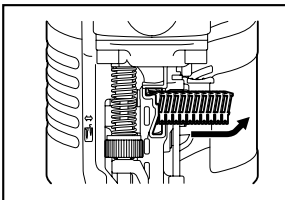

013454

**CAUTION:**

- Always disconnect the hose before cutting off the sheet.

Tear off the output sheet in the direction of the arrow when using the sheet collated nails.

**Jammed nailer**

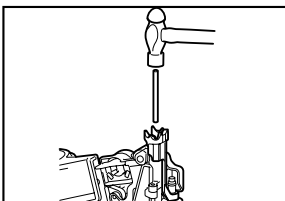

013455

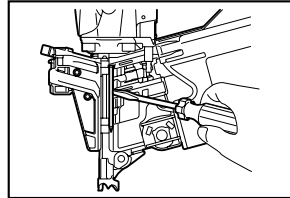

013456

**CAUTION:**

- Always disconnect the air hose and remove the nails from the magazine before cleaning a jam.

When the nailer becomes jammed, do as follows:

After depressing the latch lever and open the door, open the magazine cap and remove the nail coil. Insert a small rod or the like into the ejection port and tap it with a hammer to drive out the nail jamming from the ejection port. Reset the nail coil and close the magazine cap.

**MAINTENANCE**

**CAUTION:**

- Always disconnect the air hose from the tool before attempting to perform inspection or maintenance.
- Never use gasoline, benzene, thinner, alcohol or the like. Discoloration, deformation or cracks may result.

**Drain tool**

Remove the hose from the tool. Place the tool so that the air fitting faces down to the floor. Drain as much as possible.

**Cleaning of tool**

Iron dust that adhere to the magnet can be blown off by using an air duster.

**Cap**

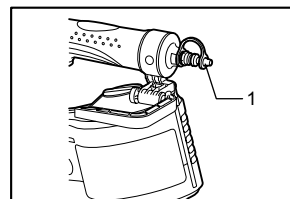

1. Cap

013459

When not in use, disconnect the hose. Then cap the air fitting with the cap.

## Storage

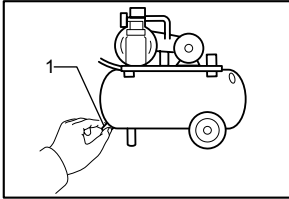

1. Drain cock

004317

When not in use, the nailer should be stored in a warm and dry place.

Maintenance of compressor, air set and air hose  
After operation, always drain the compressor tank and the air filter. If moisture is allowed to enter the tool, it may result in poor performance and possible tool failure.



004320

Keep the air hose away from heat (over 60°C, over 140°F), away from chemicals (thinner, strong acids or alkalis). Also, route the hose away from obstacles which it may become dangerously caught on during operation. Hoses must also be directed away from sharp edges and areas which may lead to damage or abrasion to the hose.

To maintain product SAFETY and RELIABILITY, repairs, any other maintenance or adjustment should be performed by Makita Authorized or Factory Service Centers, always using Makita replacement parts.

## OPTIONAL ACCESSORIES

### ⚠ CAUTION:

- These accessories or attachments are recommended for use with your Makita tool specified in this manual. The use of any other accessories or attachments might present a risk of injury to persons. Only use accessory or attachment for its stated purpose.

If you need any assistance for more details regarding these accessories, ask your local Makita Service Center.

- Nails
- Air hoses
- Safety goggles

### NOTE:

- Some items in the list may be included in the tool package as standard accessories. They may differ from country to country.

## MAKITA LIMITED ONE YEAR WARRANTY

### Warranty Policy

Every Makita tool is thoroughly inspected and tested before leaving the factory. It is warranted to be free of defects from workmanship and materials for the period of ONE YEAR from the date of original purchase. Should any trouble develop during this one year period, return the COMPLETE tool, freight prepaid, to one of Makita's Factory or Authorized Service Centers. If inspection shows the trouble is caused by defective workmanship or material, Makita will repair (or at our option, replace) without charge.

This Warranty does not apply where:

- repairs have been made or attempted by others:
- repairs are required because of normal wear and tear:
- the tool has been abused, misused or improperly maintained:
- alterations have been made to the tool.

IN NO EVENT SHALL MAKITA BE LIABLE FOR ANY INDIRECT, INCIDENTAL OR CONSEQUENTIAL DAMAGES FROM THE SALE OR USE OF THE PRODUCT. THIS DISCLAIMER APPLIES BOTH DURING AND AFTER THE TERM OF THIS WARRANTY.

MAKITA DISCLAIMS LIABILITY FOR ANY IMPLIED WARRANTIES, INCLUDING IMPLIED WARRANTIES OF "MERCHANTABILITY" AND "FITNESS FOR A SPECIFIC PURPOSE," AFTER THE ONE YEAR TERM OF THIS WARRANTY.

This Warranty gives you specific legal rights, and you may also have other rights which vary from state to state. Some states do not allow the exclusion or limitation of incidental or consequential damages, so the above limitation or exclusion may not apply to you. Some states do not allow limitation on how long an implied warranty lasts, so the above limitation may not apply to you.

EN0006-1