

PRODUCT SPECIFICATIONS

Elkay Floor Mount Double Foot Valve. Overall dimensions are 5-5/8" x 4-7/8" x 2". Made of Chrome-plated Brass.

Material:	Chrome-plated Brass
Dimensions:	5-5/8" x 4-7/8" x 2"
Shipping Weight:	3 lbs.

- Double foot mixing valve.
- 1/2" I.P.S. female inlets and outlet.
- Pedals are smooth chrome plated and color indexed.



AMERICAN PRIDE. A LIFETIME TRADITION.
Like your family, the Elkay family has values and traditions that endure. For almost a century, Elkay has been a family-owned and operated company, providing thousands of jobs that support our families and communities.

[Clean and Care Manual \(PDF\)](#)
[Limited Warranty \(PDF\)](#)

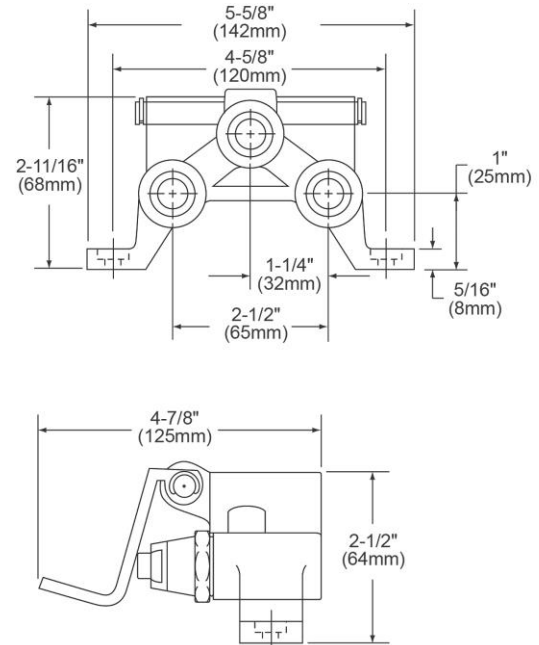

PART: _____ QTY: _____

PROJECT: _____

CONTACT: _____

DATE: _____

NOTES: _____

APPROVAL: _____

In keeping with our policy of continuing product improvement, Elkay reserves the right to change product specifications without notice. Please visit elkay.com for the most current version of Elkay product specification sheets. This specification describes an Elkay product with design, quality, and functional benefits to the user. When making a comparison of other producers' offerings, be certain these features are not overlooked.