

### EN INTRODUCTION

This instruction sheet provides you with the information required to safely own and operate your Little Giant pump. Retain these instructions for future reference.

The Little Giant pump you have purchased is of the highest quality workmanship and material, and has been engineered to give you long and reliable service. Little Giant pumps are carefully tested, inspected, and packaged to ensure safe delivery and operation. Please examine your pump carefully to ensure that no damage occurred during shipment. If damage has occurred, please contact the place of purchase. They will assist you in replacement or repair, if required.

**READ THESE INSTRUCTIONS CAREFULLY BEFORE ATTEMPTING TO INSTALL, OPERATE, OR SERVICE YOUR LITTLE GIANT PUMP. KNOW THE PUMP'S APPLICATION, LIMITATIONS, AND POTENTIAL HAZARDS. PROTECT YOURSELF AND OTHERS BY OBSERVING ALL SAFETY INFORMATION. FAILURE TO COMPLY WITH THESE INSTRUCTIONS COULD RESULT IN PERSONAL INJURY AND/OR PROPERTY DAMAGE!**

### DESCRIPTION

Little Giant submersible grinder pumps are recommended for use in basins or lift stations and are suitable for pumping residential sewage, effluent, wastewater, and other non-explosive, non-corrosive liquids.

Little Giant grinder pumps utilize a cutting mechanism, located on the suction side of the pump, that cuts solids into a slurry. A semi-vortex, non-clog impeller then passes this slurry directly through the volute and into the discharge line.

Little Giant automatic grinder pumps are equipped with a float switch that allows the pumps to operate automatically by cycling them on and off. The float switches are attached to the pumps at a pre-determined tether length of 9". **CHECK THE TETHER LENGTH ON YOUR PUMP TO ENSURE THAT IT HAS NOT CHANGED DURING SHIPPING.** A tether length of more than 9" could damage the pump by allowing it to run dry.

Little Giant offers complete control panel systems for automatic operation along with a complete line of alarms, basins, covers, and check valves. A Little Giant pump panel or capacitor and relay kit must be used for proper operation of manual pump.

Little Giant pumps are carefully packaged, 100% inspected, and tested to ensure safe operation and delivery. When you receive your pump,

examine it carefully to determine that there are no broken or damaged parts which might have occurred during shipment. If damage has occurred, make notation and notify the firm from which you purchased the pump. They will assist you in replacement or repair. If required, pump must be installed by experienced professionals only, in accordance with local plumbing and electrical codes.

### SPECIFICATIONS

- Discharge Size:** 1-1/4" FNPT vertical
- Operating Capabilities:** 140 °F (60 °C)
- Pump Housing:** Cast iron with epoxy paint coating
- Volute:** Cast iron with epoxy paint coating
- Impellers:** Brass with pressure relief vanes
- Motor:** 3450 rpm with automatic high-temperature protection
- Hardware:** 300 Series stainless steel
- Bearings:** Upper and lower ball
- Shaft Seal:** Type 21, mechanical, spring loaded, rotating carbon with fluoroelastomer (FKM) bellows and stationary ceramic with fluoroelastomer (FKM) O-ring
- Power Cord:** 14 AWG 3-conductor, copper, stranded – GP-A  
14 AWG 4-conductor, copper, stranded – GP-M
- Cooling:** The motor housing contains a dielectric oil to cool the motor and lubricate the bearings and seals. This pump is capable of operating with the motor housing partially exposed for extended periods of time, providing sufficient motor cooling and bearing lubrication. However, for the best cooling and the longest motor life, the liquid level being pumped should normally be above the top of the cast iron motor cover.
- Cutters:** 440C stainless steel, hardened to Rockwell 60C

### SAFETY GUIDELINES



**WARNING: RISK OF ELECTRIC SHOCK. READ INSTRUCTIONS AND SAFETY GUIDELINES THOROUGHLY. FAILURE TO FOLLOW THESE COULD RESULT IN SERIOUS INJURY OR PROPERTY DAMAGE!**

**WARNING: DURING NORMAL OPERATION THE SWITCH AND PUMP ARE IN CONTACT WITH WATER. EXERCISE EXTREME CAUTION WHEN WORKING NEAR THESE AREAS!**

Ensure that rising water can not reach electrical connections. Refer to the National Electrical Code and local requirements. A separate branch circuit is recommended for each pump. Do not use an extension cord.

Always turn off the circuit breaker before touching, servicing, or repairing the switch or pump.

### PUMP PERFORMANCE AND SIZING

ITEM NO.	MODEL NO.	HP	PH	VOLTS	HZ	AMPS/ WATTS	GPM @ HEAD							SHUT- OFF	POWER CORD
							10'	20'	40'	60'	80'	100'	120'		
520861**	GP-A231-20	2	1	208-230	60	13.9/3200	33	32	31	30	25	20	10	130'	20'
580862	GP-M231-15	2	1	208-230	60	13.9/3200	33	32	31	30	25	20	10	130'	15'
520863*	GP-A231-30	2	1	208-230	60	13.9/3200	33	32	31	30	25	20	10	130'	30'
520864	GP-M231-30	2	1	208-230	60	13.9/3200	33	32	31	30	25	20	10	130'	30'
520870	GP-M233-30	2	3	208-230	60	10/1300	33	32	31	30	25	20	10	130'	30'
520871	GP-M463-30	2	3	460	60	4.5/1025	33	32	31	30	25	20	10	130'	30'
520872	GP-M573-30	2	3	575	60	3.0/850	33	32	31	30	25	20	10	130'	30'

\*\* Float and Leg Kit Included

\* Leg Kit Included

Do not stand in water while changing fuses, resetting circuit breakers, or repairing the switch.

This pump is supplied with a grounding conductor. To reduce the risk of electric shock, be certain that it is connected only to a properly grounded, grounding-type receptacle or ground wire in the junction box.

When a pump is in a basin, etc., do not touch motor housing, pipes or water until unit is unplugged or shut off. If your installation has water or moisture present, do not touch wet area until all power has been turned off. If shut-off box is not accessible, call the electric company to shut off service to the house, or call a certified electrician for instructions. Failure to follow this warning can result in fatal electric shock.

In any installation where property damage and/or personal injury might result from an inoperative or leaking pump due to long term power outages, discharge line blockage or any other reason, a backup system with an alarm should be installed.

Do not use to pump flammable or explosive fluids such as gasoline, fuel oil, kerosene, etc. Failure to follow this warning can result in personal injury and/or property damage.

The pump motor is equipped with an internal thermal protector switch that opens to stop the motor when exceeding normal operating temperatures or the pump draws excessive current. This switch will reset itself and start the pump when cooled to normal temperatures.

During normal operation the grinder pump is immersed in water. Also, during rain storms, water may be present in the surrounding area of the pump. Use caution to prevent bodily injury when working near the pump.

To minimize possible fatal electrical shock hazard, use extreme care when changing breakers. Do not stand in water while changing breakers or insert anything other than the properly rated breaker in the breaker socket.

Do not operate the pump in a dry basin. This will cause the pump to become extremely hot, causing burns if touched and/or damage to the pump.

Do not check or add oil to the motor. The pump housing is sealed. A high-grade, dielectric oil devoid of water has been put into the motor housing at the factory. Use of other oil could cause serious electric shock and/or permanent damage to the pump and void warranty.

Do not install the pump in locations classified as hazardous in accordance with the National Electric Code, ANSI/NFPA 70.

Do not place hands, feet, or clothing near the cutter mechanism when there is any possibility the pump is connected to a power source. This pump contains a cutting mechanism with very sharp edges that can cause severe bodily injury.

## INSTALLATION (PUMP)



**NOTE:** For best results, use a complete, factory-built basin package system. This system includes optimum materials of construction for operation.

1. Install the pump in a suitable gas-tight basin that is at least 24" in diameter and 48" deep, and vented in accordance with local plumbing codes.
  2. Place the pump on a hard level surface. Never place pump directly on clay, earth, or gravel surfaces. If you are unable to suspend the pump intake at least 3-1/2" from the bottom of the basin, use the provided leg accessory kit (available from Little Giant).
  3. The pump can be installed with ABS, PVC, polyethylene, or galvanized steel pipe. If the pump is suspended by the discharge on a guide rail system, use the proper adapters to connect any non-metal pipe to the discharge.
  4. Use a check valve in the discharge line to prevent back-flow of liquid into the basin. The check valve should be a free-flow valve that will easily pass solids. A ball check valve is recommended.
- CAUTION:** For best performance when handling solids, install the check valve horizontally. If installed vertically, solids may settle in the valve and prevent it from opening at start-up.
5. To allow for cleaning of the check valve or removal of the pump, install a gate valve following the check valve.

For automatic operation GP-M pump must be wired into a control panel. Installation instructions are included with all Little Giant control panels and should be referred to for installation.

Pump will not run if wired directly into an electrical outlet. This pump requires a Little Giant capacitor kit and/or control panel, which contains the appropriate start and run capacitors in conjunction with a relay for proper operation. Refer to the instruction manual for capacitor kit or control panel operation values. If this pump is run with incorrect capacitors or relay, there could be severe damage to the pump motor and/or control panel.

### 3-PH MODELS

Improper impeller rotation will result in damage to the pump. Rotation must be checked at installation. After completing the wiring and with the disconnect switch in the "OFF" position, lay the pump on the side to observe the direction of the rotation through the intake. Note: contact with pump when energized could result in electrical shock. Turn disconnect switch to the "ON" position momentarily. The impeller should be rotating counterclockwise. An alternate method is to observe the kickback of the freely suspended pump as it starts. The kickback should be in counterclockwise direction looking onto the top of the pump. To change the direction of rotation, interchange any two of the white, red, or black wires of the pump at the disconnect box.

Figure 1

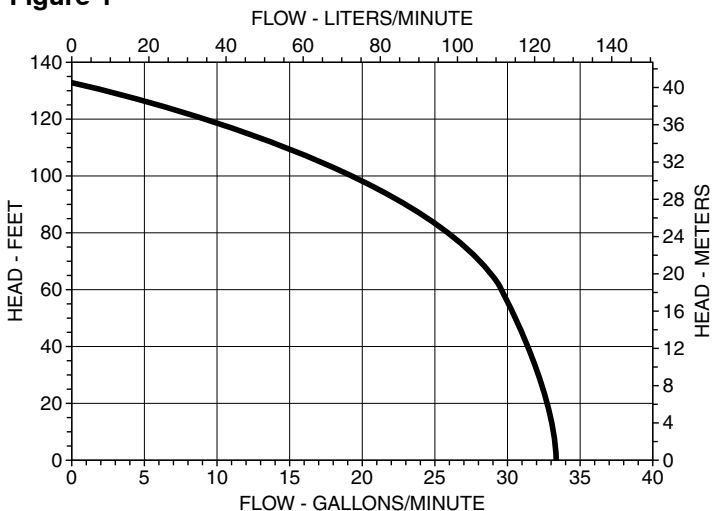

PUMP PERFORMANCE CURVE

## WIRING



**WARNING:** Check local electrical and building codes before installation. The installation must be in accordance with their regulations as well as the most recent edition of the National Electric Code (NEC).

1. Connect or wire the pump to a dedicated circuit with no other outlets or equipment in the circuit line.
2. Ensure that the circuit breaker is of ample capacity in the electrical circuit (Table 1).

HP	VOLTS	CIRCUIT BREAKER AMPS
2	208-230	20

Table 1

1-PH WINDING RESISTANCE VALUES						
HP	SPEED	VOLTS	PH	WINDING RESISTANCE IN OHMS		
				BLACK TO WHITE	BLACK TO RED	RED TO WHITE
2	3450	208-230	1	1.1	2.2	3.3

Table 2

The motor windings have a fixed resistance value and must be close to those given in chart. To check winding resistance values, disconnect pump cord from control panel and measure resistance at cord end. Refer to control panel instructions for complete wiring diagram.

T1	Common	Black
T4	Main	White
T5	Auxiliary	Red

Table 3

3-PH WINDING RESISTANCE VALUES						
HP	SPEED	VOLTS	PH	WINDING RESISTANCE IN OHMS		
				BLACK TO WHITE	BLACK TO RED	RED TO WHITE
2	3450	230	3	1.8	3.0	3.0
2	3450	460	3	6.6	6.5	6.5
2	3450	575	3	10.3	10.3	10.3

Table 4

Figure 2

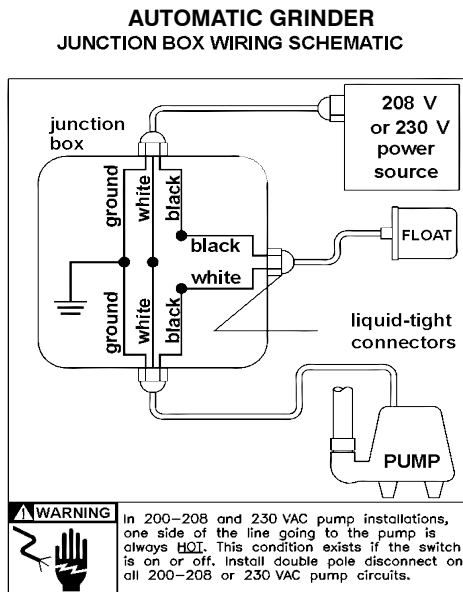

### LIQUID LEVEL CONTROL (FLOAT SWITCH)

The RFSN-20 liquid level control is designed to be used with the GP-A automatic grinder pumps. It uses a switch sealed in a plastic float cylinder. When the fluid level in the basin causes the cylinder to float to an approximate angle of 45°, the switch activates and starts the pump.

#### ELECTRICAL SPECIFICATIONS

230 VAC, 60 Hz, Single-Phase

Maximum pump running current 20 amps

Maximum pump starting current 120 amps

Recommended for use on pumps of 3 hp or less provided pump draw does not exceed 20 running amps or 120 starting amps.

#### INSTALLATION

The automatic grinder pump is shipped with the float switch installed at the factory. The float switch is attached to the pump at a pre-determined tether length of 9". **CHECK THE TETHER LENGTH ON YOUR PUMP TO ENSURE THAT IT HAS NOT CHANGED DURING SHIPPING.** A tether length of more than 9" could damage the pump by allowing it to run dry. Once the pump is installed, adjust the switch if necessary (see TESTING section).

### AUTOMATIC GRINDER

Figure 3

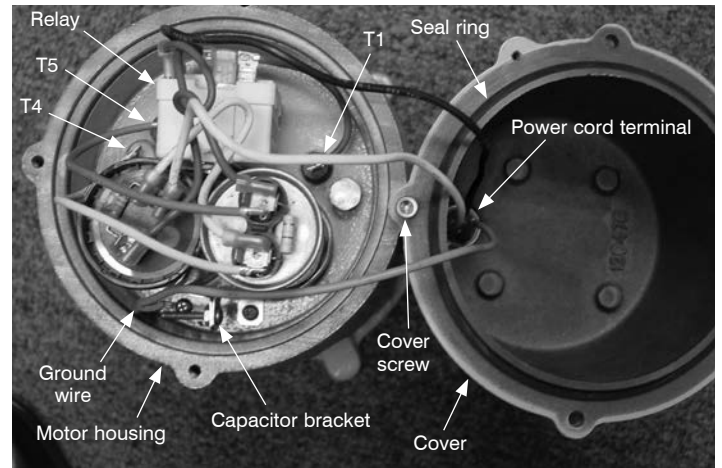
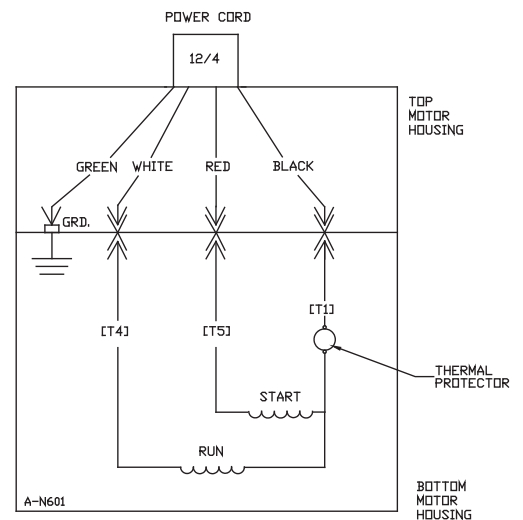

Figure 4



WIRING DIAGRAM MANUAL GRINDER

#### WIRING

The automatic grinder pump requires use of a junction box for wiring the float switch to the pump power cord. Wiring the junction box could result in possible injury due to electric shock if not performed by a certified electrician. Little Giant assumes no responsibility for improper wiring of the pump/float switch in the junction box (Figure 2).

#### INSTALLATION (CAPACITOR/RELAY KIT)



**WARNING:** When working on pump or switch, always disconnect pump power cord in addition to shutting off circuit breaker or removing the fuse.

**WARNING:** Remove **ONLY** the four 3/16" hex head capacitor/relay cover screws. Removing other screws can result in the loss of cooling fluid and possible permanent damage to the pump.

The GPA-CK capacitor/relay kit contains:

- 270-324 MFD, 250 V, start capacitor
- 50 MFD, 370 V, run capacitor
- Motor start relay
- Capacitor bracket

Refer to Figure 3, Figure 7, and the following instructions to install the capacitor/relay kit:

1. Remove the pump from power.
2. Thoroughly clean the pump.

3. Remove **ONLY** the four 3/16" hex head capacitor/relay cover screws. Use one screw to temporarily mount the cover upside down on the motor housing.
4. Carefully remove the white (T4), red (T5), and black (T1) wires from the white, red, and black terminals on the motor housing. Using an ohmmeter, verify that the motor coil resistance values are within the specifications shown in Figure 7. If the resistance values are too low or high (open circuit), the pump must be replaced.
5. Remove the old capacitor assembly from the motor housing by removing the screw holding the relay to the capacitor bracket, and then removing the two screws holding the capacitor bracket to the housing.
6. Remove the green, black, and white wires from the power cord terminal in the cover.
7. Remove the ground wire from the motor housing.
8. Remove the old seal ring from the cover and thoroughly clean the surfaces on the cover and the gland in the motor housing where the seal ring will seat. If any foreign material is left on the seal contact surface the seal will not function properly and the pump will fail. Lightly lubricate the new seal ring with petroleum jelly and, being careful not to twist it, install the ring onto the cover. Confirm that the seal ring is not twisted after it is installed.
9. Install the 12" green ground wire from the kit. Be certain that a #8 lock washer is on the #8 x 1/4 inch screw, then screw it securely into the motor housing. For easier installation, place the screw and lock washer inside the ground lug while installing. Attach the other end of the ground wire (female) to the ground pin on the power cord terminal using needle nose pliers, being careful to push it straight onto the male terminal. Gently pull on the wire to confirm that it is securely attached. See the "POWER CORD ASSEMBLY LOOKING INTO PIN SIDE" section of Figure 7 to confirm that the wire is attached properly. Check the connection by using an ohmmeter to confirm continuity from the green wire of the power cord to an unpainted part of the motor housing. The reading should be within a few tenths of ohms of zero for the length of the power cord.
10. Install the new capacitor assembly using the two #8 x 1/4 inch screws and lock washers through the two capacitor bracket screw holes. Temporarily remove the relay to install one of the screws holding the capacitor bracket to the motor housing.
11. Tighten both capacitor bracket screws and re-install the relay.
12. Connect the 12" black and 12" white wires to the remaining pins on the power cord terminal using needle nose pliers. Gently pull on each wire to confirm that it is securely attached. Connect the shorter black, white, and red wires by pushing them straight on to the black, white, and red terminals, respectively, in the motor housing. Gently pull on each wire to confirm that it is securely attached.
13. Confirm that there is no foreign material on the seal ring or in the motor housing gland for the seal ring. Re-install the cover by gently rotating it onto the motor housing. This will allow the wires to fall inside the housing without binding between the capacitors and the cover. Ensure that the float switch is properly located (Figure 7), then install the four 3/16" capacitor housing cover screws.
14. Refer to the MAINTENANCE AND SERVICING section and confirm that the volute is not clogged or cutters damaged. Verify once more that the ground is properly attached by checking resistance from the green ground wire of the power cord to one of the cover screws. Resistance should be very low if properly grounded. If not, go back to Step 9. Check the resistance between the black and white leads and verify that it is between 1 and 2 ohms.
15. Test the pump as described in the TESTING section.

### TESTING



**WARNING**

**WARNING:** The cutters inside this pump are dangerous. Do not allow anything to enter the pump during testing.

1. Secure the pump so that the starting torque of the motor does not cause it to make contact with anyone or anything when it starts. Ensure that nothing will enter the intake.
2. Wire the pump according to the Liquid Level Control section and Junction Box Wiring Schematic (Figure 2), ensuring that the voltage matches that listed on the pump nameplate.
3. Apply power.
4. With the float switch hanging freely, verify that the motor remains off. Lift the float switch to approximately 45° and verify that the motor engages and turns freely. Allow the float switch to hang freely and verify that motor disengages.
5. Once the pump is securely installed, fill the basin with water and observe the operation of the float.

**WARNING:** Never make float switch adjustments with the power on. Always be certain that power is off before making adjustments.

6. Adjust the tether length to between 6" and 9" (Figure 7). If necessary, adjust the direction or angle that the power cord exits the pump.

**CAUTION:** The float or ball portion of the switch must not touch the pump, the walls of the basin, the plumbing, or any wiring in the basin as it floats up or down. Contact with obstacles may cause the pump to continue running without water, or to stop running when water is present, damaging the pump or other property.

7. Go back to Capacitor/Relay Installation Step 1 if test is not successful, or see the Troubleshooting section.

### TYPICAL AUTOMATIC GRINDER PUMP WITH BASIN ASSEMBLY

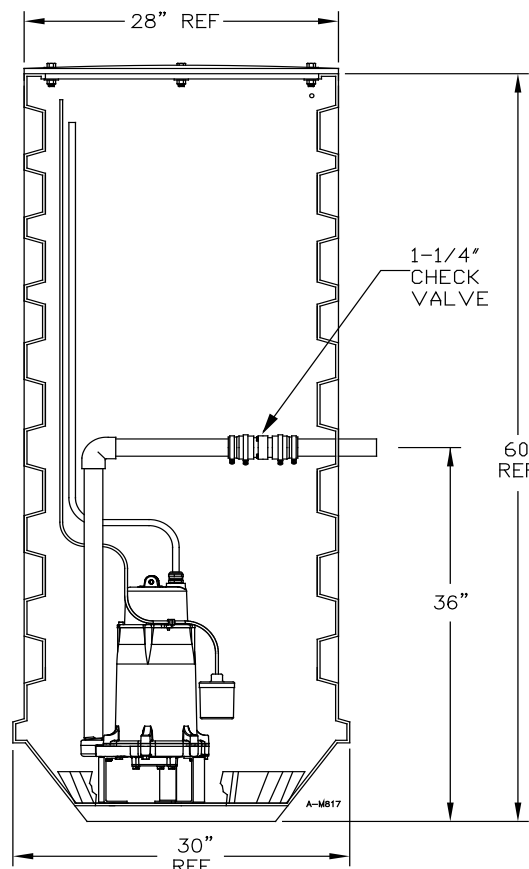

**LEG KIT (599078) MUST BE USED WITH HARD-PIPED BASINS**

**Figure 5**

## MAINTENANCE AND SERVICING



**WARNING:** Before working on pump or switch, always disconnect pump power cord in addition to shutting off circuit breaker or removing the fuse. Always wear eye protection.

**WARNING:** This pump is equipped with a cutting mechanism that has very sharp edges. Use caution when working on or near these parts.

**CAUTION:** Do not remove motor housing seal plate screws. The motor section of the pump is permanently lubricated with dielectric oil and sealed at the factory. Removal of these screws by anyone other than an authorized service center will break the seal and void the warranty.

**CAUTION:** Clean the pump of all debris and deposits before disassembling.

1. Lay the pump on its side on a smooth, hard surface.
2. Scribe a mark between the seal plate and volute, then remove the three 1-1/2" hex head screws.
3. To gain access to the rotating cutter, remove the volute by carefully tapping and prying it off the seal plate, taking care not to damage the seal plate or volute mounting surfaces.
4. To gain access to the stationary cutter, remove the retaining plate by removing the three 1/2" hex head screws. **NOTE:** The stationary cutter can be removed from the volute without having to remove the volute.
5. Remove the stationary cutter from the volute. If the stationary cutter is worn, it can be turned over once to use the other cutter edge. If the stationary cutter is damaged, it must be replaced.
6. Under good light, inspect the two edges of the rotating cutter. If the rotating cutter edges appear dull, pitted, or otherwise damaged, the cutter should be replaced.

REPLACEMENT PARTS			
ITEM NO.	PART NO.	DESCRIPTION	QTY.
1	928048	Square nitrile seal ring (7.356 ID)	1
2	14940131	Kit, cutters, rotating/stationary	1
3	120476	Retaining plate, cutter	1
4	14940256	Screw, washer, hex head, 3/8-16 x 1-1/2", stainless	3
5	903740	Screw, washer, hex head, 5/16-18 x 1/2", stainless	3
6	520859	Kit, Run/Start capacitor/relay	1

**Table 3**

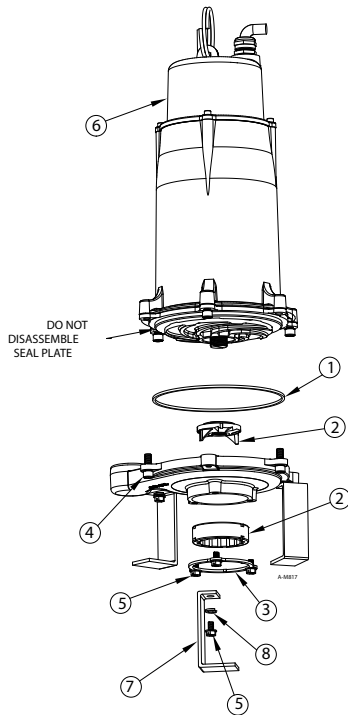
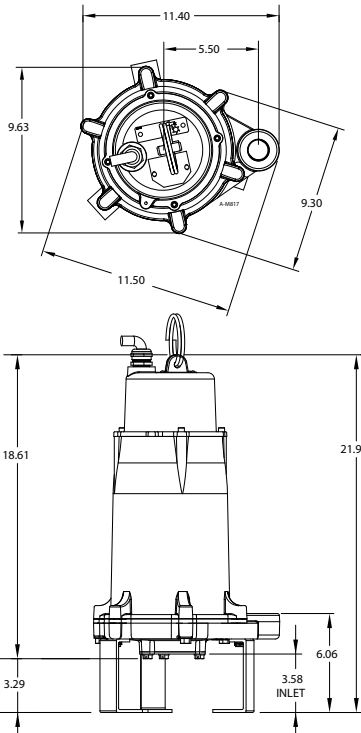

**Figure 6**

7. Remove the rotating cutter by first securing the impeller from rotating using a large, straight screwdriver inserted in the end of the motor shaft. Using a rubber mallet, tap the rotating cutter to unscrew it in a counterclockwise direction. Localized heating may help loosen the cutter.
8. Thoroughly inspect the motor shaft and rotating cutter threads, and remove any residue or debris. Chase the shaft with a 1-12 UNF die if necessary.
9. Before installing the new rotating cutter, secure the impeller from rotating using a large, straight screwdriver inserted in the end of the motor shaft. Gently tap on the impeller vane using a rubber mallet (clockwise). Apply a drop of Loctite 242 to the new rotating cutter threads and install the cutter onto the motor shaft. Secure the shaft with the screwdriver and tap the rotating cutter tight onto the impeller pilot and flush with the mating surfaces.
10. Install the stationary cutter into the volute. Reassemble the cutter retaining ring with the three flange hex head cap screws, and torque them to 100 in-lbs (11 N-m).
11. Thoroughly clean the volute and seal plate mounting surfaces. Any debris on the mounting surfaces can cause misalignment.
12. Reassemble the volute to its original orientation by realigning the scribe marks. Because of the tight pilot fit, use a rubber mallet to mate the volute to the seal plate, then install the 3 flange hex head cap screws. Torque the screws to 100 in-lbs (11 N-m) with a drop of Loctite 242.
13. Be sure the rotating cutter and impeller turn freely.

REPLACEMENT PARTS			
ITEM NO.	PART NO.	DESCRIPTION	QTY.
5	599078	Screw, washer, hex head, 5/16-18 x 1/2", stainless	3
7		Leg, accessory	3
8		Washer, lock, 5/16", stainless	3

**Table 4**  
**LEG KIT (GLK) #599078**



**Figure 7**

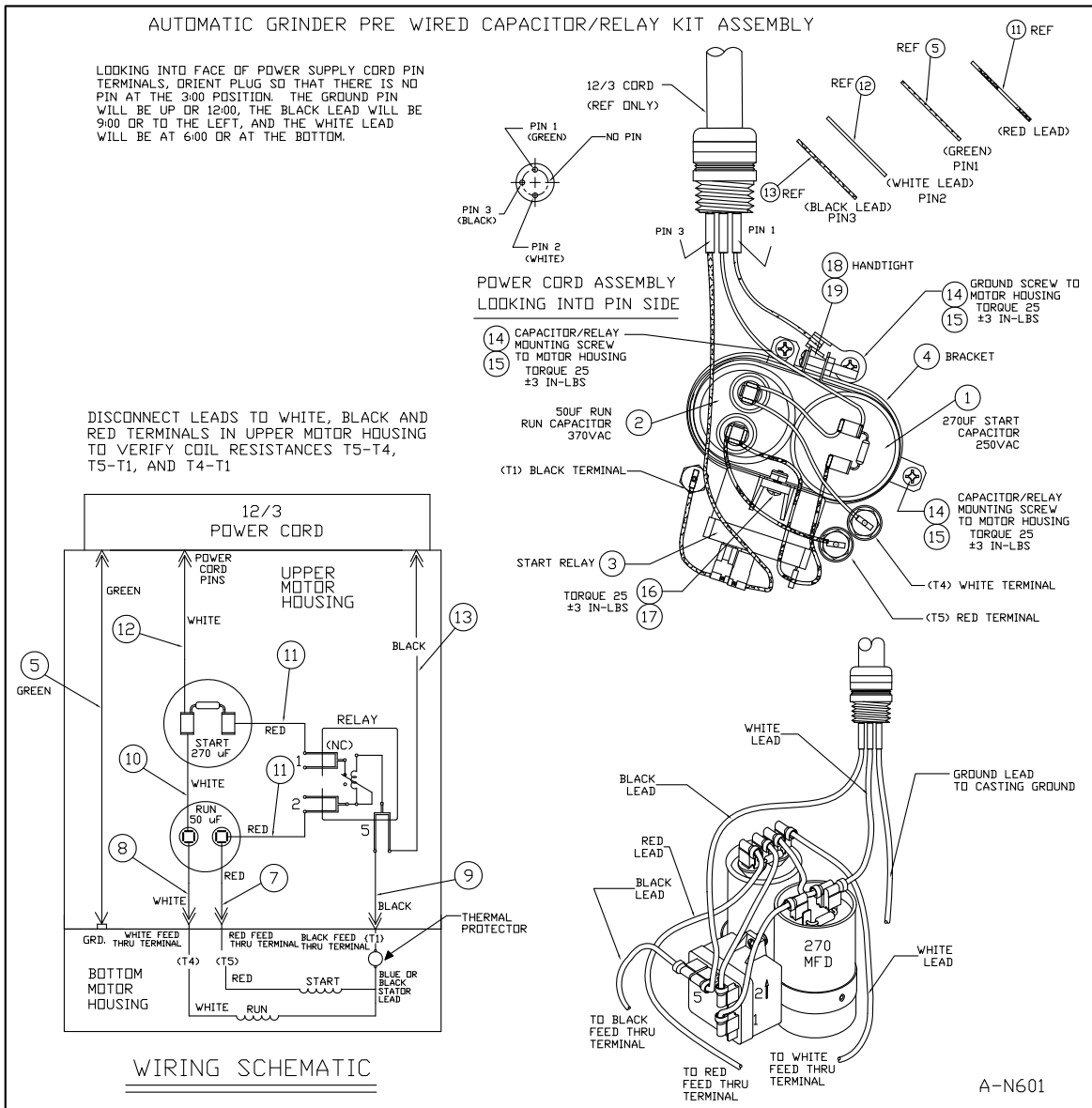

**Figure 8**

REPLACEMENT PARTS			
ITEM NO.	PART NO.	DESCRIPTION	QTY.
1	950532	Capacitor, 270 mfd, 250 V, 2.00" Dia	1
2	950519	Capacitor, 50 mfd, 370 V, 1.75" Dia	1
3	950537	Relay, potential, start, 400 V, 50 amp	1
4	*	Bracket, capacitor, dual, relay, zinc-plated, cold roll	1
5	*	Wire lead assy., 12", green, w/terminals, from power cord	1
6	*	Seal ring, nitrile, 5.359" I.D. x .134" wall, cover seal (not shown)	1
7	*	Wire lead assy., 7.00", red, w/flag terminal and pin terminal	1
8	*	Wire lead assy., 7.00", white, w/flag terminal and pin terminal	1
9	*	Wire lead assy., 3.75", black, w/flag terminal and pin terminal	1
10	*	Wire lead assy., 5.50", white, w/flag terminals	1

REPLACEMENT PARTS			
ITEM NO.	PART NO.	DESCRIPTION	QTY.
11	*	Wire lead assy., 5.50", red, w/flag terminals	2
12	*	Wire lead assy., 12", white, w/flag terminal and pin terminal	1
13	*	Wire lead assy., 12", black, w/flag terminal and pin terminal	1
14	*	Screw, machine, 8-32 x 1/4, Phillips, ground and capacitor bracket	3
15	*	Washer, lock, #8 (1 for ground and 2 for switch bracket mounting)	3
16	*	Screw, machine, 6 x 3/8, pan head, stainless, relay	1
17	*	Nut, hex, nylon, 6-32, locknut, relay	1
18	*	Screw, machine, 8-32 x 1, Phillips, panhead, capacitor bracket	1
19	*	Nut, hex, 8-32, locking, serrated (for capacitor bracket)	1

\*Item not for sale. Shown for reference only.

**Table 6**

**Capacitor/Relay Kit with Hardware (GPA-CK) #520859**

## TROUBLESHOOTING



If pump does not operate properly, consult the Troubleshooting table.

**WARNING:** Before working on pump or switch, always disconnect pump power cord in addition to shutting off circuit breaker or removing the fuse.

TROUBLESHOOTING		
PROBLEM	PROBABLE CAUSES	CORRECTIVE ACTIONS
Pump does not turn on.	Circuit breaker shut off or fuse removed.	Turn on circuit breaker or replace fuse.
	Accumulation of trash on or around float.	Clean float and area around float.
	Pump not wired correctly.	Check wiring diagram and connections.
	Float obstruction.	Check float path and provide clearance.
	Defective motor.	Have pump serviced by authorized service center.
	Defective float.	Disconnect switch (float), check with ohmmeter, open-infinite resistance, closed zero.
Pump will not shut off.	Float obstruction.	Check float path and provide clearance.
	Pump is air locked.	Shut power off for approximately 1 minute, then restart. Repeat several times to clear air from pump. A 3/16" hole should be drilled in discharge pipe approximately 2" above discharge connection. If there is already a hole drilled, check for stuck debris.
	Defective switch.	Disconnect switch (float), check with ohmmeter, open-infinite resistance, closed zero.
	Loose connection in level control wiring.	Check control wiring for loose or improper connection.
Pump runs but does not discharge liquid.	Check valve installed backwards.	Check flow-indicating arrow on check valve body to ensure it is installed properly.
	Check valve stuck or plugged.	Remove check valve and inspect for proper operation.
	Inlet to impeller clogged.	Remove pump from system and clean as described in maintenance section of manual.
	Pump is air locked.	Shut power off for approximately 1 minute, then restart. Repeat several times to clear air from pump. A 3/16" hole should be drilled in discharge pipe approximately 2" above discharge connection. If there is already a hole drilled, check for stuck debris.
Pump does not deliver rated capacity.	Lift too high for pump.	Check rated pump performance.
	Low voltage, speed too slow.	Check for proper supply voltage to make certain it corresponds to nameplate voltage.
	Impeller or discharge pipe is clogged.	Pull pump and clean. Check pipe for scale or corrosion.
	Impeller wear due to abrasives.	Replace worn impeller.
Pump cycles continually.	No check valve in long discharge pipe, allowing liquid to drain back into basin.	Install check valve in discharge line.
	Check valve leaking.	Inspect check valve for obstruction or defect. Clean or replace.
	Basin too small for inflow.	Install larger basin (24" min. diameter).
Pump is noisy.	Inlet may be clogged and overloading the motor.	Remove pump from system and clean as described in Maintenance section of manual.
	Grinder element may be rubbing on each other due to bent shaft or misalignment.	Have pump serviced by authorized service center.
	Defective motor bearings.	Have pump serviced by authorized service center.
Circuit breaker trips.	Improper wiring in junction box.	Check wiring in junction box (see wiring diagram). If circuit breaker continues to trip, remove pump and take it to an authorized service center.
	Obstruction inside volute causing impeller to be locked.	Refer to Maintenance section of instruction sheet and remove volute to check impeller. If circuit breaker continues to trip, remove pump and take it to an authorized service center.

## LIMITED WARRANTY

THIS WARRANTY SETS FORTH THE COMPANY'S SOLE OBLIGATION AND PURCHASER'S EXCLUSIVE REMEDY FOR DEFECTIVE PRODUCT.

Franklin Electric Company, Inc. and its subsidiaries (hereafter "the Company") warrants that the products accompanied by this warranty are free from defects in materials or workmanship of the Company that exist at the time of sale by the Company and which occur or exist within the applicable warranty period. Any distributor, sub-distributor, recipient, end-user and/or consumer agrees that by accepting the receipt of the products, the distributor, sub-distributor, recipient, end user and/or consumer expressly agrees to be bound by the terms of the warranty set forth herein.

### I. Applicable Warranty Period

The products accompanied by this warranty shall be covered by this Limited Warranty for a period of 24 months from the date of original purchase by the consumer. In the absence of suitable proof of purchase date, the warranty period of this product will begin to run on the product's date of manufacture.

### II. Instructions Applicable to this Limited Warranty

1. Consumers wishing to submit a warranty claim must return the products accompanied by this warranty to the point of purchase for warranty consideration.
2. Upon discovery of a defect, any personal injury, property damage or any other type of resulting damage, if applicable, shall be reasonably mitigated to the extent possible.
3. At its discretion, the Company may inspect products either at its facilities or in the field, and after determination of a warranty claim, will, at its option, repair or replace defective parts. Repaired or replaced parts will be returned freight prepaid by the Company.
4. This warranty policy does not cover any labor or shipping charges. The Company shall not be liable for any costs or charges attributable to any product testing, maintenance, installation, repair or removal, or for any tools, supplies, or equipment needed to install, repair, or remove any product.

### III. Limitations Applicable to this Limited Warranty

**THIS WARRANTY DOES NOT APPLY TO ANY OF THE FOLLOWING:**

1. Brushes, impeller or cam on models with brush-type motors and/or flex-vane impellers.
2. Any product that is not installed, applied, maintained and used in accordance with the Company's published instructions, applicable codes, applicable ordinances and/or with generally accepted industry standards.
3. Any product that has been subject to misuse, misapplication, neglect, alteration, accident, abuse, tampering, acts of God (including lightning), acts of terrorism, acts of war, fire, improper storage or installation, improper use, improper maintenance or repair, damage or casualty, or to an excess of the recommended maximums as set forth in the product instructions.
4. Any product that is operated with any accessory, equipment, component, or part not specifically approved by the Company.
5. Use of replacement parts not sold by the Company, the unauthorized addition of non-Company products to other Company products, and the unauthorized alteration of Company products.
6. Products damaged by normal wear and tear, normal maintenance services and the parts used in connection with such service, or any other conditions beyond the control of the Company.
7. Any product that has been used for purposes other than those for which it was designed and manufactured.
8. Any use of the product where installation instructions and/or instructions for use were not followed.
9. Products connected to voltage other than indicated on nameplate.

10. Products where the pump was exposed to any of the following: sand, gravel, cement, grease, plaster, mud, tar, hydrocarbons, hydrocarbon derivatives (oil, gasoline, solvents, etc.) or other abrasive or corrosive substances.
11. Products in which the pump has been used for pumping of liquids above 140 °F.
12. Products in which the pump was allowed to operate dry (fluid supply cut off).
13. Products in which the sealed motor housing has been opened or the product has been otherwise dismantled by customer.
14. Products in which the cord has been cut to a length of less than three feet.

The Company reserves the right at any time, and from time to time, to make changes in the design and/or improvements upon its product without thereby imposing any obligation upon itself to make corresponding changes or improvements in or upon its products already manufactured and/or previously sold. The Company further reserves the right to substitute parts or components of substantially equal quality in any warranty service required by operation of this Limited Warranty.

This written Limited Warranty is the entire warranty authorized and offered by the Company. There are no warranties or representations beyond those expressed in this document.

THIS WARRANTY AND REMEDY IS IN LIEU OF ALL OTHER WARRANTIES AND REMEDIES INCLUDING WITHOUT LIMITATION, WARRANTIES OF MERCHANTABILITY AND/OR FITNESS FOR A PARTICULAR PURPOSE, WHICH ARE HEREBY SPECIFICALLY DISCLAIMED AND EXPRESSLY EXCLUDED. CORRECTION OF NON-CONFORMITIES, IN THE MANNER AND FOR THE PERIOD OF TIME AS SET FORTH ABOVE, SHALL CONSTITUTE FULFILLMENT OF ALL LIABILITY OF THE COMPANY TO THE PURCHASER WHETHER BASED ON CONTRACT, NEGLIGENCE, OR OTHERWISE.

**THE COMPANY SHALL NOT BE LIABLE FOR INCIDENTAL, CONSEQUENTIAL OR SPECIAL DAMAGES SUCH AS, BUT NOT LIMITED TO:**

**DAMAGE TO OR LOSS OF OTHER PROPERTY OR EQUIPMENT, LOSS OF USE OF EQUIPMENT, FACILITIES OR SERVICE, LOSS OF PROFIT OR SALES, COST OF PURCHASES OR REPLACEMENT GOODS, CLAIMS OF CUSTOMERS OF THE PURCHASER, FAILURE TO WARN AND/OR INSTRUCT, LOSS OF OTHER PRODUCTS, OR COSTS OF ENVIRONMENTAL REMEDIATION, OR DIMINUTION IN PROPERTY VALUE. THE REMEDIES OF THE PURCHASER SET FORTH HEREIN ARE EXCLUSIVE, AND THE LIABILITY OF THE COMPANY SHALL NOT, EXCEPT AS EXPRESSLY PROVIDED HEREIN, EXCEED THE PRICE OF THE PRODUCTS UPON WHICH SUCH LIABILITY IS BASED. DAMAGES AS SET FORTH IN THIS PARAGRAPH SHALL BE REASONABLY MITIGATED TO THE EXTENT POSSIBLE. THIS PARAGRAPH SHALL ALSO APPLY TO ALL DAMAGES RESULTING FROM CONDITIONS SET FORTH IN SECTION III ABOVE AND (1) DEFECTS IN PRODUCT PROTOTYPES OR REPLACEMENT PART PROTOTYPES THAT HAVE NOT BEEN PUT INTO PRODUCTION, CIRCULATED AND SOLD BY THE COMPANY, AND/OR (2) DEFECTS THAT WERE NOT FOUND AT THE TIME OF SALE DUE TO SCIENTIFIC AND TECHNOLOGICAL REASONS.**

This Limited Warranty gives you specific legal rights. You may have other rights, which vary according to the applicable laws and regulations. Where any term of this warranty is prohibited by such laws, it shall be null and void, but the remainder of this warranty shall remain in full force and effect.

DISCLAIMER: Any oral statements about the product made by the seller, the Company, the representatives or any other parties, do not constitute warranties, shall not be relied upon by the user, and are not part of the contract for sale. Seller's and the Company's only obligation, and buyer's only remedy, shall be the replacement and/or repair by the Company of the product as described above. Before using, the user shall determine the suitability of the product for his intended use, and user assumes all risk and liability whatsoever in connection therewith.

---

For technical assistance, please contact ..... 800.701.7894

[www.littlegiant.com](http://www.littlegiant.com)

---