

CPU-0500 Control Quick & Easy Start-Up Guide

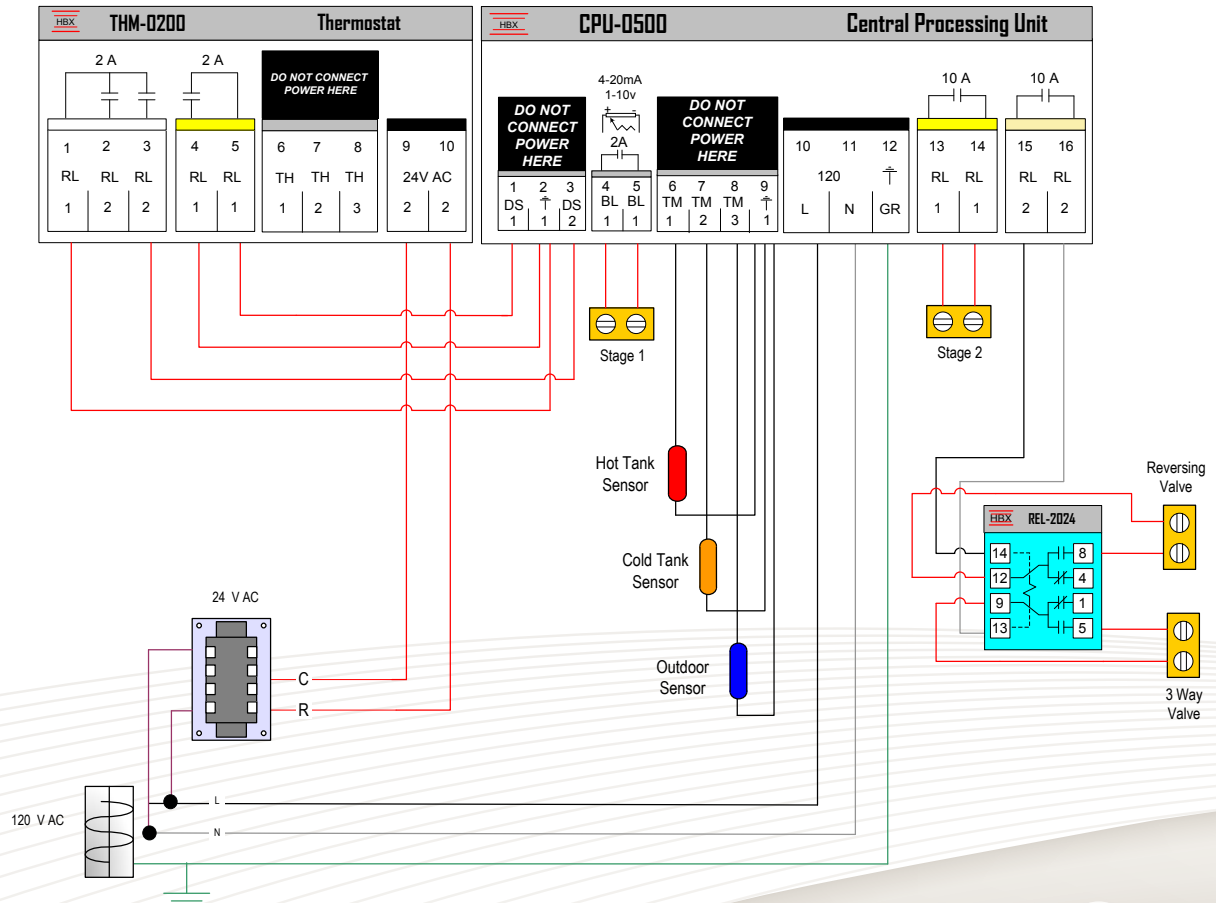

2 Stage geothermal application with separate hot and cold tank

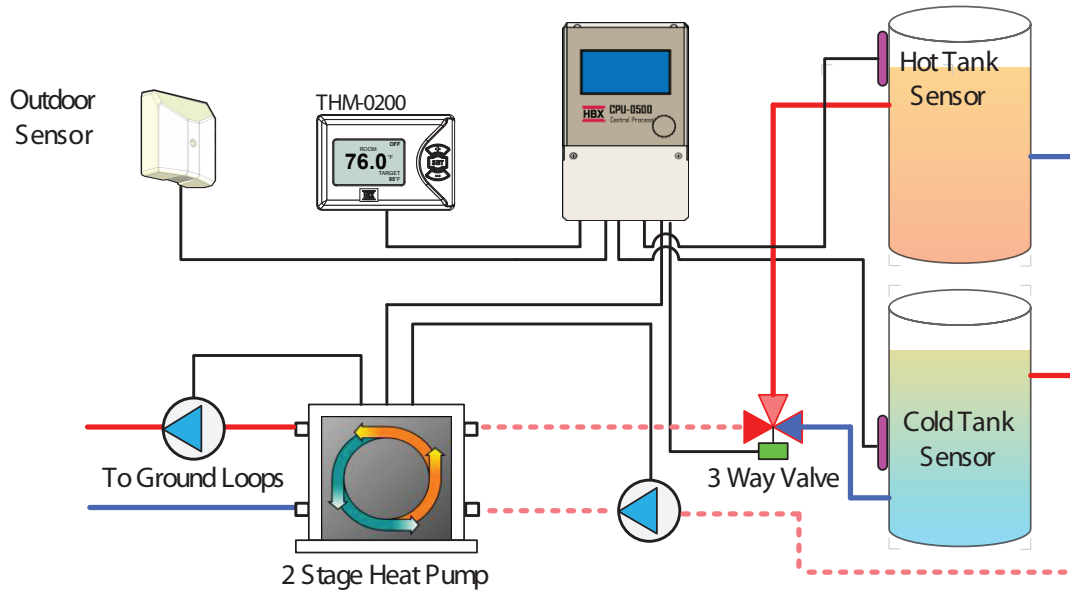

Contact Information

4516-112th Avenue SE
Calgary, Alberta T2C 2K2
CANADA

Phone: +1 (403) 720 0029
Fax: +1 (403) 720 0054
Email: info@hbxcontrols.com

Comfort
Control
Innovation

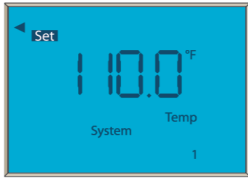

System Temperature 1

Set the System Temperature 1 for the desired heating temperature. When a heat demand is present and not in WWSD, the control will target this temperature for heating. (50°F to 200°F) Default = 110°F

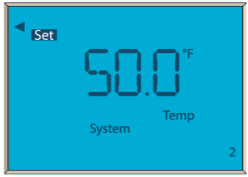

System Temperature 2

Set the System Temperature 2 for the desired cooling temperature. When a cooling demand is present and not in CWSD, the control will target this temperature for cooling. (20°F to 100°F) Default = 50°F



Design Room Temperature

This is the design room temperature. It is used in the outdoor reset design calculation. Set it to the approximate desired room temperature. (50°F to 120°F) Default: 70°F



Design Outdoor Temperature

This is the design outdoor temperature. It is used in the outdoor reset design calculation. Set this temperature to the value at which you would like to hit your maximum temperature in from the control. (Off/ -50°F to 126°F) Default: OFF

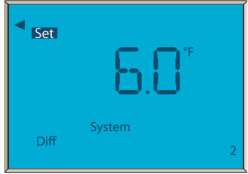

Heating Differential

This setting is used to set the heating differential. This option sets the tank differential when heating. (2°F to 50°F) Default: 10°F



Eg.) 6°F differential would be 3°F above and 3°F below.

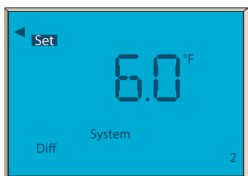

Cooling Differential

This setting is used to set the cooling differential. This option sets the tank differential when cooling. (2°F to 50°F) Default: 10°F



Eg.) 6°F differential would be 3°F above and 3°F below.



Cold Weather Shut Down

This setting is used to set the temperature at which the CPU-0500 will go into CWSD. Below this temperature the system will not allow the control to instigate cooling mode. (-50°F to 150°F) Default: 75°F

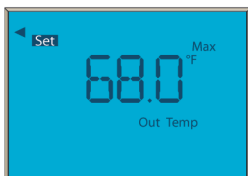

Warm Weather Shut Down (WWSD)

This setting is used to set the temperature at which the CPU-0500 will go into WWSD. Above this temperature the system will not allow the control to instigate heating mode. (20°F to 150°F) Default: 70°F

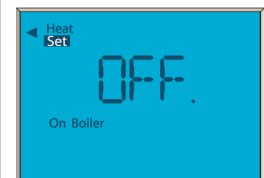

Use Backup Temperature

Set this temperature to the desired outdoor temperature that will allow the backup (stage 2) to come on. When the temperature resides above this value, the backup will not initiate a heat demand. (Off/-50°F to 199°F) Default: OFF



If set to OFF, the backup (stage 2) will come on only based on time delay.

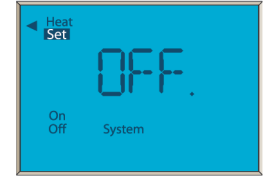

Heating or Cooling Priority

Designates either heating or cooling priority in a system. OFF = Cooling priority ON = Heating priority (ON/OFF) Default: OFF

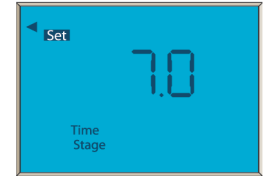

Minimum Lag Time

Choose the minimum lag time between heat pumps in a multi-heat pump application. (1 minute to 30 minutes) Default: 3 minutes

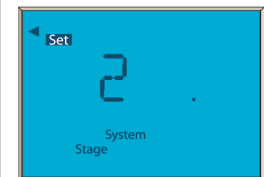

Stage Selection

1: Single stage heat pump.
2 RT: 2 stages of heat pumps with rotation.
2: 2 stages of heat pumps without rotation.
Default: 1



The time of rotation between heat pumps is 48 hours of run time. It means that the heat pumps are going to rotate when the first heat pump exceeds the second by 48 hours and vice versa.

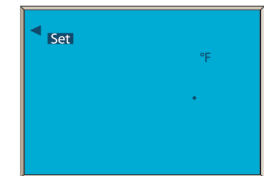

Celsius or Fahrenheit

Use this setting to change the display format between °F and °C. (°F/°C) Default: °F

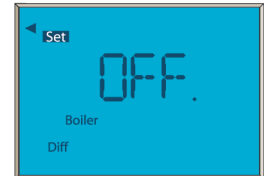

Backup Differential

This setting can be used with the USE Backup Temperature or on its own to bring the backup on. This setting is used to set a differential on the tank at which you would like the backup to come on. This setting will override the Use Backup Temperature. eg. 20.0°F Diff and System/Setpoint 100.0°F. The backup will come on at 80.0°F once the stage time has elapsed. (OFF/20 to 50°F) Default: 20°F

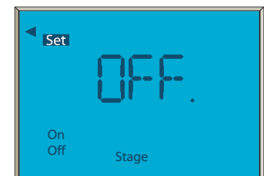

Rotate Cycles

Set the number of cycles at which you would like to rotate the heat pumps. (OFF/2 to 240) Default: OFF



Outlined fields indicate a mandatory set up.