

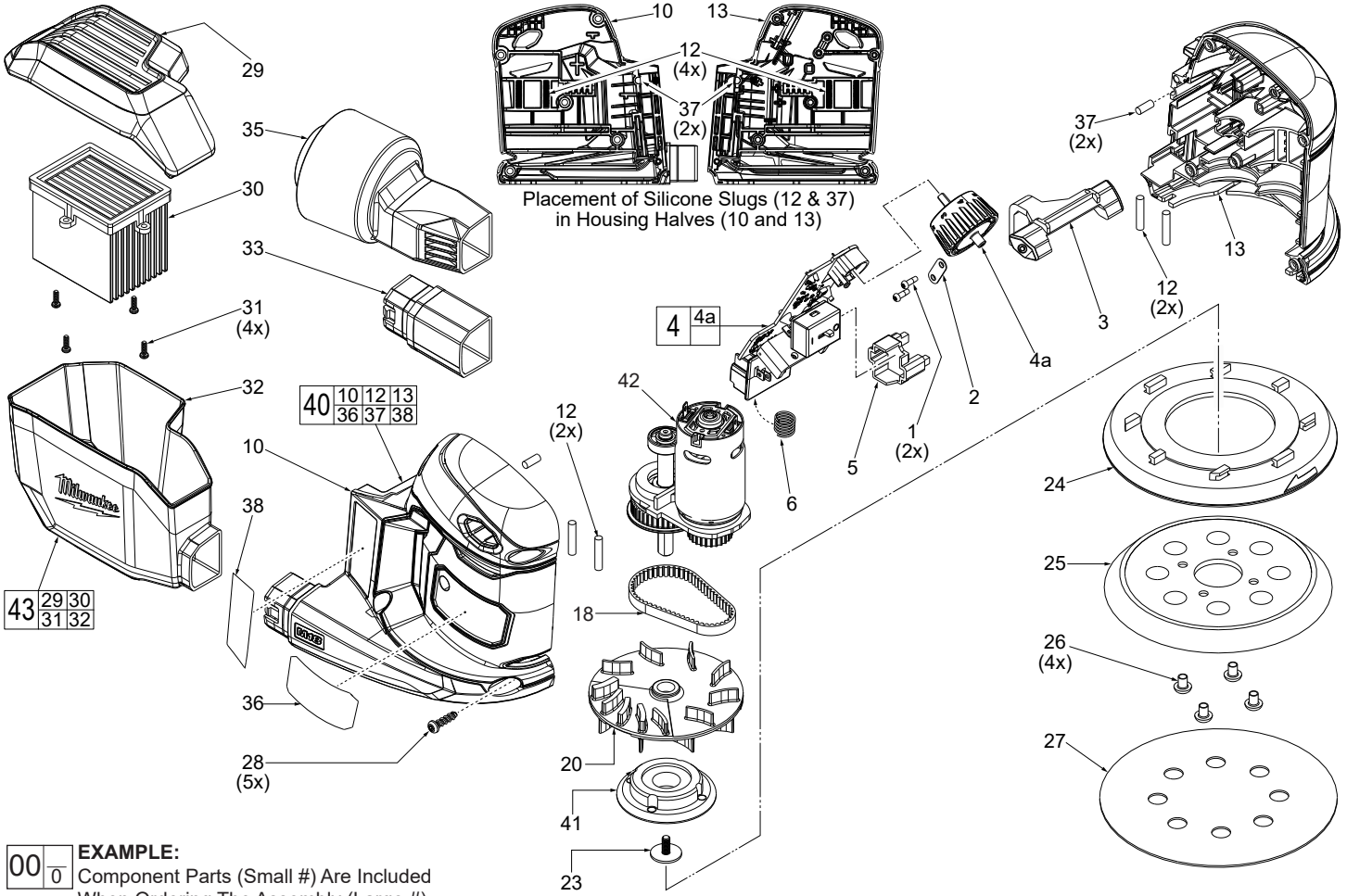

# SERVICE PARTS LIST

BULLETIN NO.  
54-38-2601

SPECIFY CATALOG NO. AND SERIAL NO. WHEN ORDERING PARTS		REVISED BULLETIN	DATE
<b>M18™ RANDOM ORBIT SANDER</b>		<b>54-38-2600</b>	June 2023
CATALOG NO. <b>2648-20</b>	STARTING SERIAL NO. <b>J49B</b>	WIRING INSTRUCTION <b>See Page 2</b>	



**EXAMPLE:**  
00 0 Component Parts (Small #) Are Included  
When Ordering The Assembly (Large #).

FIG.	PART NO.	DESCRIPTION OF PART	NO. REQ.
1	06-82-0053	M2.6 x 8mm Pan Hd. Tapt. Tamper Proof T-8 Scr.	(2)
2	44-66-0001	Speed Dial Holding Plate	(1)
3	44-10-0001	Switch Lever	(1)
4	14-20-0001	Electronics Assembly	(1)
4a	-----	Speed Dial	(1)
5	43-72-0001	Switch Holder	(1)
6	40-50-1090	Compression Spring	(1)
10	-----	Right Housing Half - Cover	(1)
12	45-30-0001	Silicone Slug	(4)
13	-----	Left Housing Half - Support	(1)
18	42-25-0003	Drive Belt	(1)
20	22-84-0980	Fan/Counter Balance	(1)
23	06-81-0165	#8-32 Washer Hd. T-20 Machine Screw	(1)
24	44-52-0970	Brake	(1)
25	51-36-7100	5" Disc Assembly (Hook & Loop) - Standard	(1)
26	06-81-0160	10-32 x 1/4" Pan Hd. T-25 Screw	(4)
27	-----	5" 80 Grit Sand Paper (Hook & Loop) - Std.	(3)
-----	-----	5" 80 Grit Sand Paper (PSA) - Optional	(1)
28	06-81-0145	8-18 x 5/8" Pan Hd. DT T-15 Screw	(5)
29	-----	Dust Box Cover with Gasket	(1)
30	-----	Dust Box Filter	(1)
31	-----	Screw	(4)
32	-----	Dust Box Body	(1)
33	31-03-0001	Extension Adapter	(1)
35	31-03-0003	Vacuum Adapter	(1)
36	12-20-0121	Service Nameplate	(1)

FIG.	PART NO.	DESCRIPTION OF PART	NO. REQ.
37	45-30-0002	Silicone Slug	(2)
38	10-20-0239	Warning Label	(1)
40	14-34-0001	Housing Kit	(1)
41	02-04-0043	Bearing Assembly	(1)
42	14-50-0002	Motor/Pulley/Shaft Assembly	(1)
43	31-15-0001	Dust Box Assembly	(1)

**FIG. NOTES**  
37,38 A clean, dry surface is essential for proper performance for any adhesive system. Area intended for application of any adhesive label or nameplate must be prepared by cleaning with isopropyl alcohol. The solvent is to be applied with a clean, lint free applicator and the surface allowed to dry before applying the label or nameplate.

SCREW TORQUE SPECIFICATIONS			SEAT TORQUE	
FIG.	PART NO.	WHERE USED	(kgf-cm)	(lb-in)
1	06-82-0053	Dial Holding Plate	4±1	3.4±1
23	06-81-0165	Spindle	25±3	21.6±2
26	06-81-0160	Disc Assembly	21±3	18.2±2
28	06-81-0145	Housing Halves	12±3	10.4±2
31	-----	Dust Box Filter	2.5±1	2.1±1

**NOTE:**

The electronics assembly (4) and motor/pulley/shaft assembly (42) are separate service assemblies. If either needs replacing, the red and blue pcba leads must be unsoldered from the motor terminals. When reconnecting the two assemblies, the red wire must be connected to the motor terminal marked with a red dot. Care must be taken to properly hook stripped area of the wire through the terminal hole. Apply enough solder to cover hooked wire strands on terminals.

1. Carefully reinstall the electronics assembly (4), being sure to place pcba and battery connector block with spring (6) firmly and squarely in corresponding cavities of left housing half (13). Trap post of speed dial (4a) with holding plate (2) and two screws (1).

2. Place drive belt (18) onto drive pulley of motor/pulley/shaft assembly (42). Work belt onto smaller pulley. Install motor/pulley/shaft assembly squarely and firmly in corresponding cavities of left housing half (13).
3. Install fan (20) onto shaft.
4. Align raised guides on top of brake (24) with slots of left housing half. Gently work guides into slots.
5. Install bearing assembly (41) onto shaft. Secure with washer head screw (23).
6. Position disc assembly (25) over brake (24), aligning the four holes in disc assembly with the four holes in the bearing assembly (41). Secure with 4 screws (26).
7. Place switch holder (5) into left housing half. Place switch of electronics assembly into switch holder.
8. Install switch lever (3) into left housing being sure that notch on bottom of lever captures the switch post.
9. Be sure all components are seated squarely and that all wires are properly routed and trapped.
10. Carefully place right housing half (10) over left housing half and into the raised guides of brake. Be sure there are no interferences prior to securing with 5 housing screws (28).
11. Prior to installing battery, check for the proper functionality of switch lever (3).
12. Install battery and check for proper operation of tool.

