

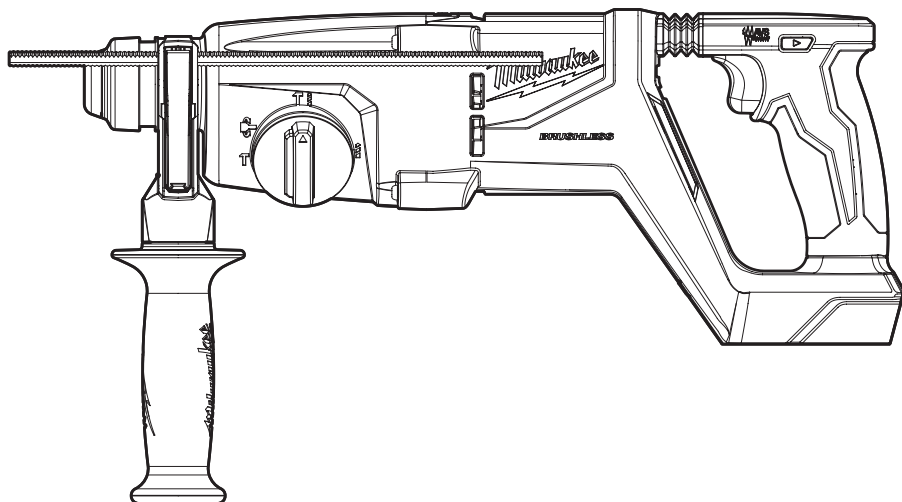

OPERATOR'S MANUAL
MANUEL de L'UTILISATEUR
MANUAL del OPERADOR



Cat. No. / No de cat.

2613-20



M18™ BRUSHLESS 1" SDS PLUS D-HANDLE ROTARY HAMMER
PERCEUSE À PERCUSSION À POIGNÉE EN "D" SANS BALAIS
DE 25 mm (1") SDS PLUS M18™
ROTOMARTILLO CON EMPUÑADURA EN "D" SIN CEPILLOS
DE 25 mm (1") SDS PLUS M18™



WARNING To reduce the risk of injury, user must read and understand operator's manual.

AVERTISSEMENT Afin de réduire le risque de blessures, l'utilisateur doit lire et bien comprendre le manuel.

ADVERTENCIA Para reducir el riesgo de lesiones, el usuario debe leer y entender el manual.

GENERAL POWER TOOL SAFETY WARNINGS

WARNING Read all safety warnings, instructions, illustrations and specifications provided with this power tool. Failure to follow all instructions listed below may result in electric shock, fire and/or serious injury. **Save all warnings and instructions for future reference.** The term "power tool" in the warnings refers to your mains-operated (corded) power tool or battery-operated (cordless) power tool.

WORK AREA SAFETY

- **Keep work area clean and well lit.** Cluttered or dark areas invite accidents.
- **Do not operate power tools in explosive atmospheres, such as in the presence of flammable liquids, gases or dust.** Power tools create sparks which may ignite the dust or fumes.
- **Keep children and bystanders away while operating a power tool.** Distractions can cause you to lose control.

ELECTRICAL SAFETY

- **Power tool plugs must match the outlet. Never modify the plug in any way. Do not use any adapter plugs with earthed (grounded) power tools.** Unmodified plugs and matching outlets will reduce risk of electric shock.
- **Avoid body contact with earthed or grounded surfaces, such as pipes, radiators, ranges and refrigerators.** There is an increased risk of electric shock if your body is earthed or grounded.
- **Do not expose power tools to rain or wet conditions.** Water entering a power tool will increase the risk of electric shock.
- **Do not abuse the cord. Never use the cord for carrying, pulling or unplugging the power tool. Keep cord away from heat, oil, sharp edges or moving parts.** Damaged or entangled cords increase the risk of electric shock.
- **When operating a power tool outdoors, use an extension cord suitable for outdoor use.** Use of a cord suitable for outdoor use reduces the risk of electric shock.
- **If operating a power tool in a damp location is unavoidable, use a ground fault circuit interrupter (GFCI) protected supply.** Use of an GFCI reduces the risk of electric shock.

PERSONAL SAFETY

- **Stay alert, watch what you are doing and use common sense when operating a power tool. Do not use a power tool while you are tired or under the influence of drugs, alcohol or medication.** A moment of inattention while operating power tools may result in serious personal injury.
- **Use personal protective equipment. Always wear eye protection.** Protective equipment such as a dust mask, non-skid safety shoes, hard hat or hearing protection used for appropriate conditions will reduce personal injuries.
- **Prevent unintentional starting. Ensure the switch is in the off-position before connecting to power source and/or battery pack, picking up or carrying the tool.** Carrying power tools with your finger on the switch or energizing power tools that have the switch on invites accidents.

- **Remove any adjusting key or wrench before turning the power tool on.** A wrench or a key left attached to a rotating part of the power tool may result in personal injury.
- **Do not overreach. Keep proper footing and balance at all times.** This enables better control of the power tool in unexpected situations.
- **Dress properly. Do not wear loose clothing or jewelry. Keep your hair and clothing away from moving parts.** Loose clothes, jewelry or long hair can be caught in moving parts.
- **If devices are provided for the connection of dust extraction and collection facilities, ensure these are connected and properly used.** Use of dust collection can reduce dust-related hazards.
- **Do not let familiarity gained from frequent use of tools allow you to become complacent and ignore tool safety principles.** A careless action can cause severe injury within a fraction of a second.

POWER TOOL USE AND CARE

- **Do not force the power tool. Use the correct power tool for your application.** The correct power tool will do the job better and safer at the rate for which it was designed.
 - **Do not use the power tool if the switch does not turn it on and off.** Any power tool that cannot be controlled with the switch is dangerous and must be repaired.
 - **Disconnect the plug from the power source and/ or remove the battery pack, if detachable, from the power tool before making any adjustments, changing accessories, or storing power tools.** Such preventive safety measures reduce the risk of starting the power tool accidentally.
 - **Store idle power tools out of the reach of children and do not allow persons unfamiliar with the power tool or these instructions to operate the power tool.** Power tools are dangerous in the hands of untrained users.
 - **Maintain power tools and accessories. Check for misalignment or binding of moving parts, breakage of parts and any other condition that may affect the power tool's operation. If damaged, have the power tool repaired before use.** Many accidents are caused by poorly maintained power tools.
 - **Keep cutting tools sharp and clean.** Properly maintained cutting tools with sharp cutting edges are less likely to bind and are easier to control.
 - **Use the power tool, accessories and tool bits etc. in accordance with these instructions, taking into account the working conditions and the work to be performed.** Use of the power tool for operations different from those intended could result in a hazardous situation.
 - **Keep handles and grasping surfaces dry, clean and free from oil and grease.** Slippery handles and grasping surfaces do not allow for safe handling and control of the tool in unexpected situations.
- ### BATTERY TOOL USE AND CARE
- **Recharge only with the charger specified by the manufacturer.** A charger that is suitable for one type of battery pack may create a risk of fire when used with another battery pack.
 - **Use power tools only with specifically designed battery packs.** Use of any other battery packs may create a risk of injury and fire.

- When battery pack is not in use, keep it away from other metal objects, like paper clips, coins, keys, nails, screws or other small metal objects, that can make a connection from one terminal to another. Shorting the battery terminals together may cause burns or a fire.
- Under abusive conditions, liquid may be ejected from the battery; avoid contact. If contact accidentally occurs, flush with water. If liquid contacts eyes, additionally seek medical help. Liquid ejected from the battery may cause irritation or burns.
- Do not use a battery pack or tool that is damaged or modified. Damaged or modified batteries may exhibit unpredictable behavior resulting in fire, explosion or risk of injury.
- Do not expose a battery pack or tool to fire or excessive temperature. Exposure to fire or temperature above 265°F (130°C) may cause explosion.
- Follow all charging instructions and do not charge the battery pack or tool outside the temperature range specified in the instructions. Charging improperly or at temperatures outside the specified range may damage the battery and increase the risk of fire.

SERVICE

- Have your power tool serviced by a qualified repair person using only identical replacement parts. This will ensure that the safety of the power tool is maintained.
- Never service damaged battery packs. Service of battery packs should only be performed by the manufacturer or authorized service providers.

SPECIFIC SAFETY RULES FOR ROTARY HAMMERS

Safety instructions for all operations

- Wear ear protectors. Exposure to noise can cause hearing loss.
- Use auxiliary handle(s), if supplied with the tool. Loss of control can cause personal injury.
- Hold power tools by insulated gripping surfaces, when performing an operation where the cutting tool may contact hidden wiring. Cutting accessory contacting a "live" wire may make exposed metal parts of the power tool "live" and could give the operator an electric shock.

Safety instructions when using long drill bits with rotary hammers

- Always start drilling at low speed and with the bit tip in contact with the workpiece. At higher speeds, the bit is likely to bend if allowed to rotate freely without contacting the workpiece, resulting in personal injury.
- Apply pressure only in direct line with the bit and do not apply excessive pressure. Bits can bend, causing breakage or loss control, resulting in personal injury.
- Keep hands away from all cutting edges and moving parts.
- Cut embedded rebar only if this operation does not affect the integrity of the building. If in doubt, consult a structural engineer. Tool operator fully responsible for adverse structural effects.

- AWARNING** To reduce the risk of injury, when working in dusty situations, wear appropriate respiratory protection or use an OSHA compliant dust extraction solution.

- Always use common sense and be cautious when using tools. It is not possible to anticipate every situation that could result in a dangerous outcome. Do not use this tool if you do not understand these operating instructions or you feel the work is beyond your capability; contact Milwaukee Tool or a trained professional for additional information or training.

- Maintain labels and nameplates. These carry important information. If unreadable or missing, contact a MILWAUKEE service facility for a free replacement.

- AWARNING** Some dust created by power sanding, sawing, grinding, drilling, and other construction activities contains chemicals known to cause cancer, birth defects or other reproductive harm. Some examples of these chemicals are:

- lead from lead-based paint
- crystalline silica from bricks and cement and other masonry products, and
- arsenic and chromium from chemically-treated lumber.

Your risk from these exposures varies, depending on how often you do this type of work. To reduce your exposure to these chemicals: work in a well ventilated area, and work with approved safety equipment, such as those dust masks that are specially designed to filter out microscopic particles.

SYMBOLGY



Volts



Direct Current

n₀ XXXX min⁻¹ No-Load Revolutions per Minute (RPM)



Blows per Minute (BPM)



Anti-vibration System



Read Operator's Manual



UL Listing Mark for Canada and U.S.

FUNCTIONAL DESCRIPTION

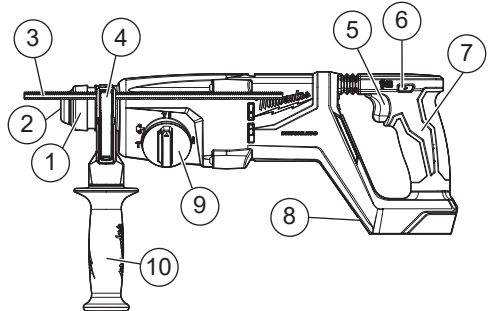

- | | |
|-----------------------|-----------------------|
| 1. Bit release collar | 6. Control switch |
| 2. Bit holder | 7. Rear handle |
| 3. Depth gauge rod | 8. LED |
| 4. Clamping lever | 9. Mode selector knob |
| 5. Trigger | 10. Side handle |

SPECIFICATIONS

Cat. No.....	2613-20
Volts.....	18 DC
Battery Type.....	M18™
Charger Type.....	M18™
RPM.....	0 - 1270
BPM.....	0 - 4580
Type.....	SDS Plus
Twist bit.....	1"
Core bit.....	2.5"
Recommended Ambient Operating Temperature.....	0°F to 125°F

ASSEMBLY

⚠WARNING Recharge only with the charger specified for the battery. For specific charging instructions, read the operator's manual supplied with your charger and battery.

Removing/Inserting the Battery

To remove the battery, push in the release buttons and pull the battery pack away from the tool.

⚠WARNING Always lock the trigger or remove the battery pack any time the tool is not in use.

To insert the battery, slide the pack into the body of the tool. Make sure it latches securely into place.

⚠WARNING Only use accessories specifically recommended for this tool. Others may be hazardous.

To reduce the risk of injury, always use a side handle when using this tool. Always brace or hold securely.

Adjusting the Side Handle Position

1. Loosen the side handle by unscrewing the side handle grip until the side handle rotates freely.
2. Rotate the side handle to the desired position.
3. Tighten the side handle grip securely.

Setting the Depth Gauge

1. Press in the clamping lever.
2. Slide the depth gauge rod backward or forward until it is set for the desired depth.

NOTE: The drilling depth is the distance between the tip of the bit and the tip of the depth gauge rod.

3. Release the clamping lever.

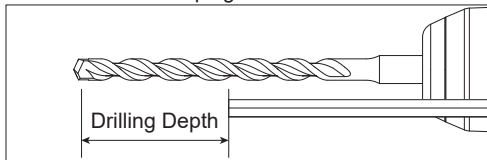

Installing Drill Bits and Chisels

NOTE: Only use accessories with SDS or SDS Plus shanks.

Be sure that the shank of the bit is clean. Dirt particles may cause the bit to line up improperly. Do not use bits larger than the maximum recommended capacity of the drill because gear damage or motor overloading may result. For best performance, be sure that the bit is properly sharpened and the shank is lightly greased before use.

1. Remove battery pack.
 2. Insert the bit or chisel into the nose of the tool.
 3. Rotate bit slowly until it aligns with the locking mechanism.
 4. Push bit into tool until it locks.
 5. Check that the bit is locked properly; it should be possible to pull the bit back and forth slightly (about 1/4").
 6. To remove bits and chisels, pull bit holder release collar toward the rear of tool and remove bit.
- NOTE:** Use caution when handling hot bits and chisels.

OPERATION

⚠WARNING To reduce the risk of injury, always remove battery pack before changing or removing accessories. Only use accessories specifically recommended for this tool. Others may be hazardous.

Keep hands away from the bit and all moving parts.

Always wear proper eye protection marked to comply with ANSI Z87.1.



When working in dusty situations, wear appropriate respiratory protection or use an OSHA compliant dust extraction solution.

Always use a side handle when using this tool. Always brace or hold securely.

Cut embedded rebar only if this operation does not affect the integrity of the building. If in doubt, consult a structural engineer. Tool operator fully responsible for adverse structural effects.

Selecting Action

MILWAUKEE Rotary Hammers have three settings: rotation only, rotary hammer, and hammer only. Always allow the motor to come to a complete stop before changing the mode selection to avoid damage to the tool.

1. For **rotation only**, rotate the mode selector so the arrow on the lever points to the twist drill  symbol.
2. For **rotary hammering**, rotate the mode selector so the arrow points to the hammer and twist drill  symbol.
3. To freely rotate the bit to the desired angle for hammering only, rotate the mode selector to the  symbol. Then, follow step 4.

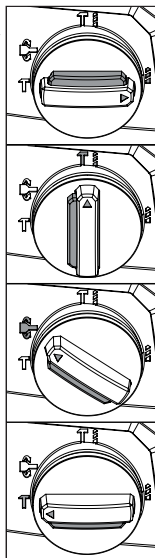

4. For **hammering only**, rotate the mode selector so the arrow points to the hammer  symbol. **NOTE:** To engage the hammering mechanism, maintain pressure on the bit. When the pressure on the bit is released, the hammering will stop.

Using the Control Switch

The control switch may be set to three positions: forward, reverse and lock. Always allow the motor to come to a complete stop before using the control switch to avoid damage to the tool.

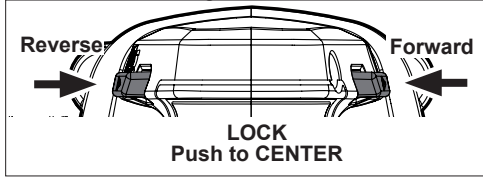

1. For **forward** (clockwise) rotation, push in the control switch from the right side of the tool. **Check the direction of rotation before use.**
2. For **reverse** (counterclockwise) rotation, push in the control switch from the left side of the tool. **Check direction of rotation before use.**
3. To **lock** the trigger, push the control switch to the center position. The trigger will not work while the control switch is in the center locked position. Always lock the trigger or remove the battery pack any time the tool is not in use.

Starting, Stopping and Controlling Speed

1. To **start** the tool, grasp the handle(s) firmly and pull the trigger.
NOTE: An LED is turned on when the trigger is pulled and will go off shortly after the trigger is released.
2. To **vary** the speed, increase or decrease the pressure on the trigger. The further the trigger is pulled, the greater the speed.
3. To **stop** the tool, release the trigger. Ensure the tool has come to a complete stop before laying the tool down.

Operating

Position the tool, grasp the handles firmly and pull the trigger. Always hold the tool securely using both handles to maintain control. This tool has been designed to achieve top performance with only moderate pressure. Let the tool do the work.

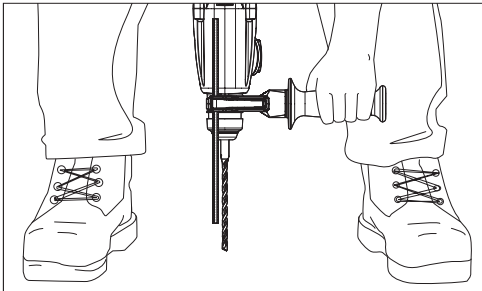

If the speed begins to drop off when drilling large or deep holes, pull the bit partially out of the hole while the tool is running to help clear dust. Do not use water to settle the dust since it will clog the bit flutes and tend to make the bit bind in the hole. If the bit should bind, a built-in, non-adjustable slip clutch prevents the bit from turning. If this occurs, stop the tool, free the bit and begin again.

Operator Force

The Anti-Vibration System provides the operator with comfort without sacrificing power or performance. Ideal operator force compresses the bellows slightly and allows the tool to work aggressively while the handle remains steady.

Excessive force compresses the bellows significantly and reduces vibration dampening. Users will be able to feel the difference and should adjust the force to the handle accordingly.

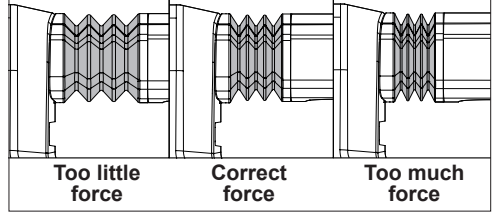

Cold Starting

If this tool is stored for a long period of time or at cold temperatures, it may not hammer initially because the lubrication has become stiff. To warm up the tool:

1. Insert and lock a bit or chisel into the tool.
2. Pull the trigger and apply force to the bit or chisel against a concrete or wood surface for a few seconds. Release the trigger.
3. Repeat until the tool starts hammering. The colder the tool is, the longer it will take to warm up.

Using Rotary Percussion Core Bits

Core Bits are useful for drilling large or long holes in concrete. MILWAUKEE Heavy-Duty Core Bits have heat-treated steel bodies with durable carbide tips. These core bits are specially designed for fast, accurate drilling with combined hammering and rotary action.

1. Clean and lubricate the threads on the adapter and core bit to make later removal easier. Thread the adapter shank to the rear of the core bit.
2. Push the guide plate onto the pointed end of the center pin. Insert the center pin and guide plate assembly into the core bit. Be sure the small end of the center pin is securely placed into the hole in the center of the core bit.
For LHS systems, screw the threaded end of the centering bit into the core bit.

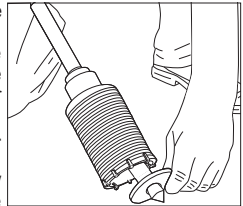
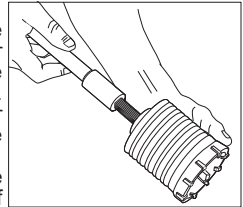

3. Insert the adapter into the nose of the tool as described in "Installing Bits and Chisels". Set the knob to the "hammering with rotation" setting.

- Press the centering bit firmly against your center mark, hold the tool firmly and pull the trigger.
NOTE: If the 48-20-5099 threaded stud is used, or a center pin and guide plate are not available, use a template or notched board to start the hole.
- Start the tool. After drilling to about the depth of the core bit teeth, remove the center pin and guide plate from the core bit (not necessary for LHS system). Resume drilling.
- To change the core bit, hold the tool upwards, pointing it away from your body, and run it briefly in forward to loosen the core bit from the adapter.
NOTE: To make deeper holes, remove the core bit, break and remove the core, then resume drilling. When drilling long or deep holes, after each inch of penetration pull the bit partially out of the hole while the tool is running, to help clear dust from the bit flutes. Dust can clog the bit flutes and can make the bit bind in the hole. If this occurs, stop the tool, free the bit and begin again.

Setting Self-Drilling Anchors

MILWAUKEE Tooth Anchor Chucks require a "B" taper adapter.

- Place the proper size tooth anchor chuck into the "B" taper adapter. Then insert the "B" taper adapter into the tool and lock it into place as described. See "Installing Bits and Chisels".

- Insert the anchor into the tooth anchor chuck. Set the knob for hammering only. Set the anchor on your mark and hammer until the teeth have penetrated the concrete.

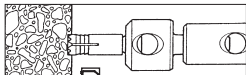

- Set the knob for hammering with rotation and drill until the chuck is 1/8" above the concrete.

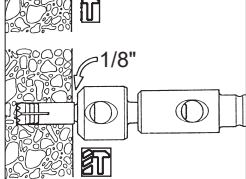

- Remove the anchor from the hole while the tool is running. Clean the dust and cuttings from the anchor several times while drilling the hole.

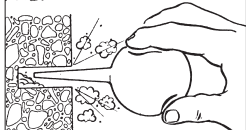

- Remove the anchor from the hole while the tool is running. Clean the dust and cuttings from the anchor by pointing it downward and turning the tool on and off several times. Clean the dust out of the hole with a vacuum cleaner or blowout bulb.

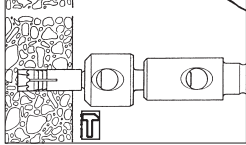

- Place the expansion plug into the anchor and insert the anchor into the hole. Switch the knob back to hammering only, and hammer the anchor firmly into the hole.

- Snap the head off of the anchor. To remove the head of anchors up to 5/8", grasp the handles firmly and pull the tool sharply towards you or snap off the anchor head with a hand hammer as shown. The anchor is now ready to receive a bolt.

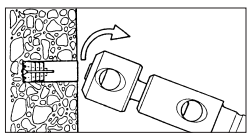

- To remove the anchor head wedged in the tooth anchor chuck, use a drift pin.

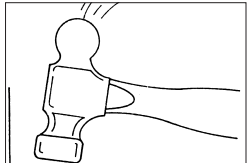

- To remove the tooth anchor chuck, remove the "B" taper adapter from the nose of the tool. Insert the drift pin supplied with the adapter into the hole on the side of the "B" taper adapter and strike it sharply to force out the tooth anchor chuck.

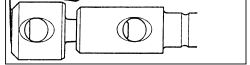

Chiseling and Chipping

MILWAUKEE Rotary Hammers may be used for chipping and chiseling. A variety of accessories are available.

When chiseling, hold the tool at an angle to the workpiece. Work from a corner or close to the edge of the workpiece, breaking off one small area at a time rather than attempting too large an area.

MAINTENANCE

WARNING To reduce the risk of injury, always unplug the charger and remove the battery pack from the charger or tool before performing any maintenance. Never disassemble the tool, battery pack or charger. Contact a MILWAUKEE service facility for ALL repairs.

Maintaining Tool

Keep your tool, battery pack and charger in good repair by adopting a regular maintenance program. Inspect your tool for issues such as undue noise, misalignment or binding of moving parts, breakage of parts, or any other condition that may affect the tool operation. Return the tool, battery pack, and charger to a MILWAUKEE service facility for repair. After six months to one year, depending on use, return the tool, battery pack and charger to a MILWAUKEE service facility for inspection.

If the tool does not start or operate at full power with a fully charged battery pack, clean the contacts on the battery pack. If the tool still does not work properly, return the tool, charger and battery pack, to a MILWAUKEE service facility for repairs.

WARNING To reduce the risk of personal injury and damage, never immerse your tool, battery pack or charger in liquid or allow a liquid to flow inside them.

Cleaning

Clean dust and debris from any vents. Keep tool clean, dry and free of oil or grease. Use only mild soap and a damp cloth to clean, since certain cleaning agents and solvents are harmful to plastics and other insulated parts. Some of these include gasoline, turpentine, lacquer thinner, paint thinner, chlorinated cleaning solvents, ammonia and household detergents containing ammonia. Never use flammable or combustible solvents around tools.

Repairs

For repairs, return the tool, battery pack and charger to the nearest authorized service center.

ACCESSORIES

⚠WARNING Use only recommended accessories. Others may be hazardous.

For a complete listing of accessories, go online to www.milwaukeetool.com or contact a distributor.

SERVICE - UNITED STATES

1-800-SAWDUST (1.800.729.3878)

Monday-Friday, 7:00 AM - 6:30 PM CST
or visit www.milwaukeetool.com

Contact Corporate After Sales Service Technical Support with technical, service/repair, or warranty questions.

Email: metproductsupport@milwaukeetool.com

Become a Heavy Duty Club Member at www.milwaukeetool.com to receive important notifications regarding your tool purchases.

SERVICE - CANADA

Milwaukee Tool (Canada) Ltd

1.877.948.2360

Monday-Friday, 7:00 AM - 4:30 PM CST
or visit www.milwaukeetool.ca

LIMITED WARRANTY USA & CANADA

This MILWAUKEE power tool* is warranted to the original purchaser from an authorized MILWAUKEE distributor only to be free from defects in material and workmanship. Subject to certain exceptions, MILWAUKEE will repair or replace any part on this power tool which, after examination, is determined by MILWAUKEE to be defective in material or workmanship for a period of five (5) years after the date of purchase unless otherwise noted. Return of the power tool to a MILWAUKEE factory Service Center location or MILWAUKEE Authorized Service Station, freight prepaid and insured, is required. A copy of the proof of purchase should be included with the return product. This warranty does not apply to damage that MILWAUKEE determines to be from repairs made or attempted by anyone other than MILWAUKEE authorized personnel, misuse, alterations, abuse, normal wear and tear, lack of maintenance, or accidents.

Normal Wear: Many power tools need periodic parts replacement and service to achieve best performance. This warranty does not cover repair when normal use has exhausted the life of a part including, but not limited to, chucks, brushes, cords, saw shoes, blade clamps, o-rings, seals, bumpers, driver blades, pistons, strikers, lifters, and bumper cover washers.

*This warranty does not cover battery packs or all power tools. Refer to the separate and distinct warranties available for those products. The warranty period for the LED in the LED Work Light (49-24-0171) and the LED Upgrade Bulb (49-81-0090) is the lifetime of the product subject to the limitations above. If during normal use the LED or LED Upgrade Bulb fails, the part will be replaced free of charge. Warranty Registration is not necessary to obtain the applicable warranty on a MILWAUKEE power tool product. The manufacturing date of the product will be used to determine the warranty period if no proof of purchase is provided at the time warranty service is requested. ACCEPTANCE OF THE EXCLUSIVE REPAIR AND REPLACEMENT REMEDIES DESCRIBED HEREIN IS A CONDITION OF THE CONTRACT FOR THE PURCHASE OF EVERY MILWAUKEE PRODUCT. IF YOU DO NOT AGREE TO THIS CONDITION, YOU SHOULD NOT PURCHASE THE PRODUCT. IN NO EVENT SHALL MILWAUKEE BE LIABLE FOR ANY INCIDENTAL, SPECIAL, CONSEQUENTIAL, OR PUNITIVE DAMAGES, OR FOR ANY COSTS, ATTORNEY FEES, EXPENSES, LOSSES OR DELAYS ALLEGED TO BE AS A CONSEQUENCE OF ANY DAMAGE TO, FAILURE OF, OR DEFECT IN ANY PRODUCT INCLUDING, BUT NOT LIMITED TO, ANY CLAIMS FOR LOSS OF PROFITS. SOME STATES DO NOT ALLOW THE EXCLUSION OR LIMITATION OF INCIDENTAL OR CONSEQUENTIAL DAMAGES, SO THE ABOVE LIMITATION OR EXCLUSION MAY NOT APPLY TO YOU. THIS WARRANTY IS EXCLUSIVE AND IN LIEU OF ALL OTHER EXPRESS WARRANTIES, WRITTEN OR ORAL TO THE EXTENT PERMITTED BY LAW, MILWAUKEE DISCLAIMS ANY IMPLIED WARRANTIES, INCLUDING WITHOUT LIMITATION ANY IMPLIED WARRANTY OF MERCHANTABILITY OR FITNESS FOR A PARTICULAR USE OR PURPOSE; TO THE EXTENT SUCH

DISCLAIMER IS NOT PERMITTED BY LAW, SUCH IMPLIED WARRANTIES ARE LIMITED TO THE DURATION OF THE APPLICABLE EXPRESS WARRANTY AS DESCRIBED ABOVE. SOME STATES DO NOT ALLOW LIMITATIONS ON HOW LONG AN IMPLIED WARRANTY LASTS, SO THE ABOVE LIMITATION MAY NOT APPLY TO YOU, THIS WARRANTY GIVES YOU SPECIFIC LEGAL RIGHTS, AND YOU MAY ALSO HAVE OTHER RIGHTS WHICH VARY FROM STATE TO STATE.

This warranty applies to product sold in the U.S.A. and Canada only. Please consult the "Service Center Search" in the Parts & Service section of MILWAUKEE's website www.milwaukeetool.com or call 1.800.SAWDUST (1.800.729.3878) to locate your nearest service facility for warranty and non-warranty service on a MILWAUKEE power tool.

RÈGLES DE SÉCURITÉ GÉNÉRALES RELATIVES AUX OUTILS ÉLECTRIQUES

⚠AVERTISSEMENT Lire toutes les consignes de sécurité, consignes, illustrations et spécifications fournies avec cet outil électrique. Ne pas suivre l'ensemble des règles et instructions peut entraîner une électrocution, un incendie ou des blessures graves. **Conserver les règles et les instructions à des fins de référence ultérieure.** Le terme "outil électrique" figurant dans les avertissements ci-dessous renvoie à l'outil électrique à alimentation par le réseau (à cordon) ou par batterie (sans fil).

SÉCURITÉ DU LIEU DE TRAVAIL

- Veillez à ce que l'aire de travail soit propre et bien éclairée. Le désordre et le manque de lumière favorisent les accidents.
- Ne pas utiliser d'outils électriques dans des atmosphères explosives, par exemple en présence de liquides, gaz ou poussières inflammables. Les outils électriques produisent des étincelles risquant d'enflammer les poussières ou vapeurs.
- S'assurer que les enfants et les curieux se trouvent à une bonne distance au moment d'utiliser un outil électrique. Les distractions peuvent causer une perte de contrôle.

SÉCURITÉ ÉLECTRIQUE

- Les fiches des outils électriques doivent correspondre à la prise secteur utilisée. Ne jamais modifier la fiche, de quelque façon que ce soit. Ne jamais utiliser d'adaptateurs de fiche avec des outils mis à la terre. Les fiches et prises non modifiées réduisent le risque de choc électrique.
- Éviter tout contact avec des surfaces mises à la terre comme des tuyaux, des radiateurs, des cuisinières et des réfrigérateurs. Le risque de choc électrique est accru lorsque le corps est mis à la terre.
- Ne pas exposer les outils électriques à l'eau ou l'humidité. La pénétration d'eau dans ces outils accroît le risque de choc électrique.
- Ne pas maltraiter le cordon d'alimentation. Ne jamais utiliser le cordon d'alimentation pour transporter l'outil électrique et ne jamais débrancher ce dernier en tirant sur le cordon. Garder le cordon à l'écart de la chaleur, de l'huile, des objets tranchants et des pièces en mouvement. Un cordon endommagé ou emmêlé accroît le risque de choc électrique.
- Pour les travaux à l'extérieur, utiliser un cordon spécialement conçu à cet effet. Utiliser un cordon conçu pour l'usage extérieur réduit les risques de choc électrique.