

# Infiniti Tankless® K-Series

## FOR OUTDOOR INSTALLATIONS ONLY

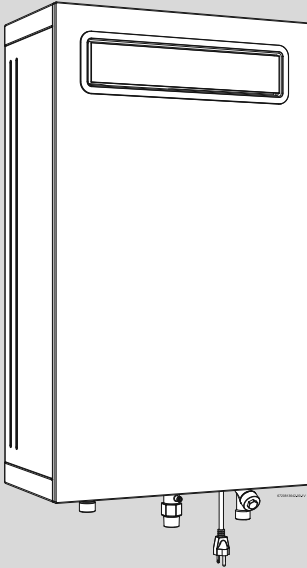

**⚠ WARNING!** Improper installation, adjustment, alteration, service or maintenance can cause injury or property damage. Refer to this manual. For assistance or additional information consult a qualified installer, service agency or the gas supplier.

### NOTICE

Upon completion of the installation, these instructions should be handed to the user of the appliance for future reference.

**⚠ WARNING:** If the information in these instructions is not followed exactly, a fire or explosion may result causing property damage, personal injury or death.

- Do not store or use gasoline or other flammable vapors and liquids in the vicinity of this or any other appliance.
- **WHAT TO DO IF YOU SMELL GAS**
  - Do not try to light any appliance.
  - Do not touch any electrical switch; do not use any phone in your building.
  - Immediately call your gas supplier from a neighbor's phone. Follow the gas supplier's instructions.
  - If you cannot reach your gas supplier, call the fire department.
- Installation and service must be performed by a qualified installer, service agency or the gas supplier.

6720816R15-3R.2V

**RTG-K-199/160N2 - 199,000/160,000 BTU/Hr - Natural Gas**

**RTG-K-199/160X2 - 199,000/160,000 BTU/Hr - Liquefied Petroleum (LP) Gas**

Temperature Modulated with Electronic Ignition Suitable for heating potable water and space heating  
(Intended for variable flow applications)

Featuring:

**STEADISSET® Technology**

and

**SRT™ Scale Reduction Technology™**

  
**BRADFORD WHITE®**  
WATER HEATERS

---

**Table of contents**

---

**1 Key to symbols and safety instructions ..... 3**

1.1 Key to symbols ..... 3

1.2 Safety instructions ..... 3

---

**2 Safety information ..... 9**

---

**3 Appliance details ..... 9**

3.1 Features ..... 9

3.2 Specifications (Technical data) ..... 11

3.3 Unpacking the heater ..... 13

3.4 General rules to follow for safe operation ..... 14

3.5 Dimensions ..... 15

---

**4 Installation instructions ..... 16**

4.2 Introduction ..... 16

4.3 Proper location for installing your heater ..... 16

4.4 Selecting heater location ..... 16

4.5 Mounting instructions ..... 17

4.5.1 Air openings ..... 18

4.6 Factory regulation ..... 18

4.7 Mounting installation for modular homes ..... 18

4.8 Gas piping & connections ..... 18

4.9 Water quality ..... 22

4.10 Water connections ..... 22

4.11 Connecting the condensate water drain ..... 23

4.12 Domestic hot water recirculation with external pump ..... 24

4.13 Adjusting the recirculation settings ..... 24

4.14 Recirculation with the RTG-K-160/199N/X1 ..... 25

4.15 Cascading Operation ..... 25

4.16 Space heating applications ..... 26

4.17 Measuring gas pressure ..... 29

---

**5 Electrical connections ..... 29**

5.1 Electrical power supply ..... 29

5.2 Position of the fuses in control unit ..... 30

---

**6 Operating Instructions ..... 31**

6.1 For your safety read before operating your water heater ..... 31

6.2 Power ..... 31

6.3 Error code reset ..... 32

6.4 Temperature selection ..... 32

6.5 Information /Adjustments menu ..... 33

6.5.1 P4 (Information) ..... 33

6.5.2 P9 (Purge) ..... 34

6.5.4 SA (Settings) ..... 35

6.5.5 SL (Temperature Limit) ..... 37

6.5.6 PE (Appliance Type) ..... 37

6.5.7 PF (Bypass Activation) ..... 37

6.6 Water actuators calibration ..... 38

6.7 Gas type ..... 38

---

**7 Maintenance and service ..... 40**

7.1 Required annual maintenance ..... 41

7.2 Winterizing for seasonal use ..... 41

7.3 Mineral scale build-up ..... 42

---

**8 Troubleshooting ..... 43**

8.1 Introduction ..... 43

8.2 Burner does not ignite when a hot water faucet is opened ..... 43

8.3 Water is too hot ..... 43

8.4 Water is not hot enough ..... 44

8.5 Low water flow/pressure ..... 44

8.6 Hot water temperature fluctuates at faucet ..... 44

8.7 Noisy burner/heater during operation ..... 44

8.8 Error codes C1, C2, CF and/or CE ..... 45

8.9 Error codes EA and/or EC ..... 45

8.10 Manifold gas pressure ..... 45

8.11 Adjusting Gas/Air flow ..... 46

8.12 CO emissions check ..... 49

---

**9 Problem solving ..... 51**

9.1 Error code diagnostics ..... 51

---

**10 Electrical diagram ..... 56**

---

**11 Sensor resistance charts ..... 58**

---

**12 Interior components diagram and parts list ..... 59**

---

**13 Protecting the environment ..... 61**

---

**14 Installer Checklist to be completed by installer upon installation ..... 61**

---

**15 Software main menu structure ..... 63**

---

**16 LIMITED TANKLESS HEATER WARRANTY ..... 64**

## 1 Key to symbols and safety instructions

### 1.1 Key to symbols

#### Warnings

In warnings, signal words at the beginning of a warning are used to indicate the type and seriousness of the ensuing risk if measures for minimising danger are not taken.

The following signal words are defined and can be used in this document:



#### **DANGER:**

**DANGER** indicates a hazardous situation which, if not avoided, will result in death or serious injury.



#### **WARNING:**

**WARNING** indicates a hazardous situation which, if not avoided, could result in death or serious injury.



#### **CAUTION:**

**CAUTION** indicates a hazardous situation which, if not avoided, could result in minor or moderate injury.

#### **NOTICE:**

**NOTICE** is used to address practices not related to personal injury.

#### Important information



The info symbol indicates important information where there is no risk to people or property.

#### Additional symbols

Symbol	Meaning
▶	a step in an action sequence
→	a reference to a related part in the document
•	a list entry
–	a list entry (second level)

Table 1

### 1.2 Safety instructions

#### **⚠ DANGER:**

#### **Before installation,**

- ▶ Read all instructions. Perform the steps in the indicated sequence.
- ▶ Have the water heater inspected by a trained service technician at least once every year.
- ▶ Failure to comply with these instructions can result in severe, possibly fatal, personal injury as well as damage to property and equipment.

#### **⚠ Danger:**

#### **Installation and servicing.**

#### **Risk of fire when soldering and brazing!**

- ▶ Take appropriate protective measures when soldering and brazing around combustible and flammable material.
- ▶ Ensure that only a licensed contractor installs or services the water heater.
- ▶ On hot components use only material with adequate temperature stability.

#### **⚠ WARNING:**

#### **Installation and commissioning.**

- ▶ In the Commonwealth of Massachusetts, the water heater must be installed by a licensed plumber.
- ▶ Do not install this device in confined spaces.

**⚠ WARNING:**

- ▶ To ensure that the water heater functions properly, follow these installation and maintenance instructions.
- ▶ Never close the blow-off line of the pressure safety valve. For safety reasons, water may escape during heating.

**⚠ DANGER:**

**Risk of explosion!**

**If you smell gas,**

- ▶ Turn off the gas shut-off valve.
- ▶ Open windows and doors if detected inside the house.
- ▶ Do not try to light the appliance.
- ▶ Do not touch any electrical switch, telephone, and do not use outlets.
- ▶ Extinguish all open flames. Do not smoke! Do not use lighters!
- ▶ Warn all occupants of the building. Do not ring doorbells!
- ▶ If you can hear gas leaking, leave the building immediately.
- ▶ Prevent others from entering the building and notify the police and fire department from outside the building and appliance surround areas.
- ▶ From outside the building, call the gas utility company and a trained and certified installer.

**⚠ DANGER:**

**If you smell flue gas inside the house,**

- ▶ Switch off the appliance.
- ▶ Open windows and doors.
- ▶ Inform the certified installer who installed the appliance to change appliance installation location.

**⚠ DANGER:**

**Risk of poisoning!**

**Insufficient ventilation may cause toxic flue gas to escape.**

- ▶ Never close off or reduce the size of the air intake and outlet openings.
- ▶ The appliance must not be operated until any obstructions have been removed.
- ▶ Inform the customer of the problem and the associated dangers.

**⚠ DANGER:**

**Danger of explosion of flammable gases.**

- ▶ Work on gas components may only be carried out by a trained and certified installer.
- ▶ Installation, gas and flue connection, initial commissioning, electrical connections and annual maintenance must only be carried out by a trained and certified installer.

**⚠ CAUTION:**

**Combustion air**

- ▶ Keep the combustion air free of corrosive substances (halogenated hydrocarbons that contain chlorine or fluorine compounds).

**⚠ WARNING:****Never shut off safety valves!**

- ▶ Water may escape from the safety valve at any time when the water is being heated.

**⚠ WARNING:****Inspection/maintenance**

- ▶ Servicing and repairs may only be carried out by a trained and certified installer.
- ▶ Immediately correct all faults to prevent system damage.
- ▶ Use only Bradford White spare parts! Damage caused by the use of parts not supplied by Bradford White may void the warranty.

**⚠ CAUTION:****Instruct the customer.**

- ▶ Explain to the customer how the appliance works and how to operate it.
- ▶ Inform the customer that he/she must not carry out any alterations or repairs.

**⚠ DANGER:****Risk of electric shock!**

- ▶ Ensure that only an authorized contractor performs electrical work.
- ▶ Before performing electrical work, disconnect the power and secure the unit against unintentional reconnection.

- ▶ Ensure the system has been disconnected from the power supply.

**⚠ DANGER:****Risk of scalding at the hot water fixture!**

- ▶ When the water heater is in operation, temperatures in excess of 120 °F (49 °C) can occur. To limit the temperature at the faucet, install a thermostatic DHW mixing valve.
- ▶ Water heated for washing the laundry, dishes and for other cleaning purposes can cause scalding and permanent injuries.
- ▶ Children, disabled and elderly people are at highest risk of being scalded. Never leave such individuals in the tub or shower unattended under any circumstances. Children must not be allowed to operate hot water faucets themselves.
- ▶ If the building has occupants in the above groups who operate hot water faucets, or state laws / local ordinances stipulate specific water temperatures, take the following precautions:
  - Use the lowest possible temperature setting.
  - To prevent scalding, install a tempering device, such as an automatic mixing valve, at hot water faucet or water heater. Select and install the automatic mixing valve in accordance with the valve

manufacturer's recommendations and instructions.

- ▶ Water exiting from drain valves can be extremely hot. To avoid injuries:
  - Check that all connections are tight.
  - Direct exiting water away from people.
- ▶ Measures must be taken to protect against excessive temperature and pressure! Installation of a pressure relief valve (PRV) is required.

**⚠ WARNING:**

**Electrical safety**

To protect against corrosion and ensure compliance with the rules for electrical safety, observe the following points:

- ▶ Use metal fittings for potable water heating systems with plastic piping.
- ▶ Use only original accessories from the manufacturer.
- ▶ When installation of the water heater is complete, inspect the ground conductor (including metal fittings).

**⚠ CAUTION:**

**Maintenance**

- ▶ Inspect and maintain the water heater on a yearly basis. Service as needed.
- ▶ Use only genuine spare parts.

**⚠ WARNING:**

**Flooding**

- ▶ After a flood, do not use the appliance if any part has been submerged. Damage to appliances that have been submerged can be quite severe and pose numerous safety risks.
- ▶ Every appliance that has been submerged must be replaced.

**⚠ WARNING:**

**For your safety**

- ▶ Do not store or use gasoline or other flammable, combustible or corrosive vapors and liquids in the vicinity of this or any other appliance.

**⚠ DANGER:**

**Fatal accidents!**

Carbon monoxide poisoning.

- ▶ Carefully plan where you install the heater. Correct combustion air supply is very important. If a gas appliance is not installed correctly, fatal accidents can result such as carbon monoxide poisoning or fire.
- 

**⚠ DANGER:**

**Fatal accidents!**

Carbon monoxide poisoning.

- ▶ Do not install the appliance in confined spaces, for example: garages, porches, etc.
-

**⚠ DANGER:****Electric shock!**

- ▶ Field wiring connections and electrical grounding must comply with local codes, or in the absence of local codes, with the latest edition of the National Electric Code, ANSI/NFPA 70, or in Canada, all electrical wiring must comply with the local codes and the Canadian Electrical Code, CSA C22.1 Part 1.

**⚠ DANGER:****Electric shock!**

Shock hazard: line voltage is present.

- ▶ Before servicing the water heater, unplug power supply cord from outlet. Failure to do so could result in severe personal injury or death.

**⚠ WARNING:****Damage to the appliance from over pressure.**

- ▶ The heater must be disconnected from the gas supply piping system during any pressure testing of that system at test pressures greater than or equal to 0.5 psi (14" W.C.).

**NOTICE:**

- ▶ The appliance should be located in an area where leakage of the heater or connections will not result in damage to the area adjacent to the appliance or to lower floors of the structure. When such locations cannot be avoided, it is recommended that a suitable drain pan, adequately drained, be installed under the appliance. The pan must not restrict combustion air flow.

**⚠ WARNING:**

- ▶ The maximum inlet gas pressure must not exceed the value specified by the manufacturer and the minimum value listed is for the purpose of input adjustment.

**NOTICE:**

- ▶ If a water heater is installed in a closed water supply system, such as one having a backflow preventer in the cold water supply line, means shall be provided to control thermal expansion. Contact the water supplier or local plumbing inspector on how to control this situation.



**WARNING:**

**Fire danger!**

- ▶ Keep appliance area clear and free from combustible materials, gasoline and other flammable vapors and liquids.
- 

**NOTICE:**

- ▶ Do not obstruct the flow of combustion and ventilation air.
- 



**WARNING:**

**Risk of scalding and property damage.**

- ▶ Precautions must be taken prior to manually operating the pressure relief valve to avoid contact with hot water discharged from the pressure relief valve and to prevent water damage.
- 

**NOTICE:**

**Appliance damage!**

- ▶ Label all wires prior to disconnection when servicing controls. Wiring errors can result in improper and dangerous operation. Verify proper operation after servicing.
- 



**WARNING:**

**System damage!**

- ▶ If a relief valve discharges periodically, this may be due to thermal expansion in a closed water supply system. Contact the water supplier or local plumbing inspector on how to correct this situation. Do not plug the relief valve.
- 



**WARNING:**

**Personal Injury from toxic chemicals.**

- ▶ Toxic chemicals, such as those used for boiler treatment, shall not be introduced into the potable water used for space heating.
- 



**WARNING:**

**Personal Injury from toxic chemicals.**

- ▶ A water heater which will be used to supply potable water shall not be connected to any heating system or component(s) previously used with a nonpotable water heating appliance.
-



## 2 Safety information

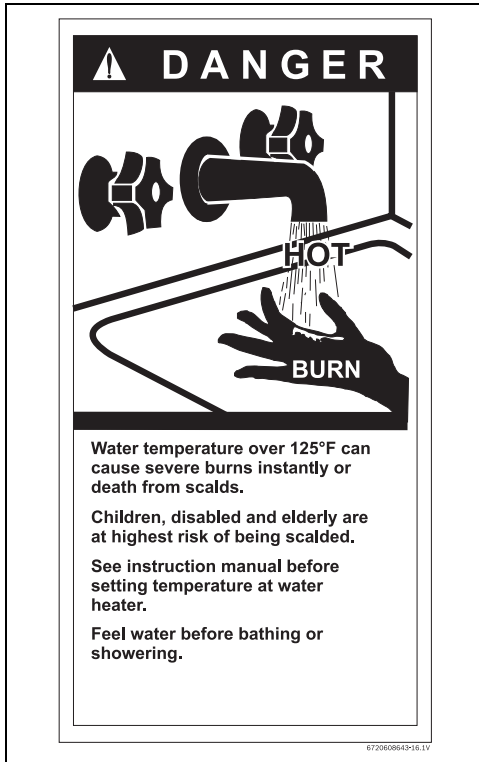

Fig. 1

The chart below shows the relationship between water temperature and time until there is a risk of scalding. It can be used as the basis for determining the safest water temperature for your application.

Temperature	Time to severe scalding <sup>1)</sup>
120 °F (48 °C)	longer than 5 minutes
125 °F (51 °C)	1.5 to 2 minutes
130 °F (54 °C)	approx. 30 seconds
135 °F (57 °C)	approx. 10 seconds
140 °F (60 °C)	less than 5 seconds
145 °F (62 °C)	less than 3 seconds
150 °F (65 °C)	approx. 1.5 seconds
155 °F (68 °C)	approx. 1 second

- 1) Source: Moritz, A.R. and Henriques, F.C., Jr. (1947). Studies of thermal injury. II. The relative importance of time and surface temperature in the causation of cutaneous burns, Am J of Pathol, 23, 695-720.

Table 2 Approximate time-temperature relationship until there is a risk of scalding

**! WARNING:**

CANCER AND REPRODUCTIVE HARM  
 WWW.P65WARNINGS.CA.GOV  
 AS REQUIRED BY THE STATE OF CALIFORNIA PROPOSITION 65.

This Bradford White water heater complies with the State of California Lead Law (AB1953).

## 3 Appliance details

### 3.1 Features

Appliance models

- Infiniti Tankless® K-Series residential models
  - maximum temperature 120 °F<sup>1)</sup>

Parts

- High power segmented burner with low NOx emissions. Modulating gas valve with pressure regulator.
- Modulating water valve.
- Bypass water valve for quick response to changing water flows (For 160 model must be manually activated).
- Burner power segmentation with modulation range from 1:22.

High quality materials for long working life

- Copper heat exchanger.
- Stainless Steel 316L condensing heat exchanger

Features

- Compact space saver: mounts on a wall with a supplied bracket.
- Easy minimum to achieve low output power.
- Opti-flow that auto adjusts unit for easy installation.
- Easily removable one-piece cover.
- On/Off and Temperature remote control.
- Program button (Selectable temperature default).
- Failure codes for easy diagnostics and repair.

- 1) Can be programmed to achieve 140 °F

## Appliance details

---

- Real-time diagnostics for troubleshooting/informational purposes.
- Built in freeze protection.
- Integrated siphon to limit condensate freezing in external condensate pipes.

Note: The freeze prevention kit is designed to provide protection for the water heater down to **approximately 5 °F (-15 °C) for short term conditions only when protected from direct wind exposure**. It will not protect the appliance in areas where the temperature is routinely expected to be below freezing. Drain the water heater in the event of power outage in freezing conditions.

- The freeze prevention kit will not protect plumbing outside the appliance from freezing. Precautions should be taken.

### Accessories

- Aquastat kit (7736504584)
- Tank loading NTC (7736504583)
- External Recirculation Cable (7736504585)
- Cascading kit (7736502750)



---

Bradford White is constantly improving its products, therefore specifications are subject to change without prior notice.

---

### 3.2 Specifications (Technical data)

Approved in US/Canada

Technical characteristics	Units	Infiniti Tankless® K-Series RTG-K-199N/X2	Infiniti Tankless® K-Series RTG-K-160N/X2
<b>Capacity</b>			
Maximum flow rate at a 35 °F (19.4 °C) rise <sup>1)</sup>	GPM (l/min)	11.2 (42.4)	9 (34)
Maximum flow rate at a 45 °F (25 °C) rise	GPM (l/min)	8.7 (32.9)	7(26.7)
Maximum flow rate at a 55 °F (30.6 °C) rise	GPM (l/min)	7.2 (27.5)	5.8 (21.9)
Maximum flow rate at a 65 °F (36.1 °C) rise	GPM (l/min)	6.1 (23.1)	4.8 (18.2)
Maximum flow rate at a 75 °F (41.7 °C) rise	GPM (l/min)	5.2 (19.7)	4.2 (15.9)
Maximum flow rate at a 90 °F (50 °C) rise	GPM (l/min)	4.4 (16.6)	3.5 (13.2)
Maximum output	BTU/hr (kW)	197 010 (57.7)	157 608 (46.2)
Maximum input <sup>2)</sup>	BTU/hr (kW)	199 000 (58.3)	160 000 (46.64)
Thermal efficiency (Efficiency in %)	%	> 99%	> 99%
Minimum Input <sup>3)</sup>	BTU/hr (kW)	9 000 (2.6)	9 000 (2.6)
<b>Temperature Control<sup>4)</sup></b>			
Selection range	°F (°C)	100 - 120 <sup>5)</sup> (38 - 49)	100 - 120 <sup>5)</sup> (38 - 49)
Default temperature	°F (°C)	120 (49)	120 (49)
Temperature stability <sup>6)</sup>	°F (°C)	± 2 (± 1)	± 2 (± 1)
<b>Gas Requirement</b>			
Gas connection	inches	¾"	¾"
Peak load inlet gas pressure <sup>7)</sup>			
Propane	water column	8" - 13"	8" - 13"
Natural Gas	water column	3.5" - 10.5"	3.5" - 10.5"
<b>Water</b>			
Bottom hot water connection NPT	inches	¾"	¾"
Bottom cold water connection NPT	inches	¾"	¾"
Minimum water flow <sup>8)</sup>	GPM (l/min)	0.45 (1.7)	0.45 (1.7)
Maximum water pressure	PSI (bar)	150 (10.3)	150 (10.3)
Minimum recommended water pressure	PSI (bar)	18 (1.2)	18 (1.2)
Minimum well pressure	PSI (bar)	30 (2.1)	30 (2.1)
Water valve material		Polymer (PPS) (Polypropylene Sulfide)	Polymer (PPS) (Polypropylene Sulfide)
<b>Combustion</b>			
CO level	ppm	≤ 250 (measured)	≤ 250 (measured)
CO <sub>2</sub> level (set from factory)	%	see table 23	see table 23
<b>Dimensions</b>			
Depth	inches (mm)	9 <sup>27</sup> / <sub>32</sub> (250)	9 <sup>27</sup> / <sub>32</sub> (250)
Width	inches (mm)	18 <sup>19</sup> / <sub>32</sub> (471,5)	18 <sup>19</sup> / <sub>32</sub> (471,5)
Height	inches (mm)	31½ (800)	31½ (800)
Net weight	pounds (kg)	77.5 (31.2)	73.2 (33.2)

## Appliance details

Technical characteristics	Units	Infiniti Tankless® K-Series RTG-K-199N/X2	Infiniti Tankless® K-Series RTG-K-160N/X2
Gross weight	pounds (kg)	89.95 (40.8)	85.54 (38.8)
<b>Electrical</b>			
Nominal	V AC	120	120
Frequency	Hz	60	60
Amperage (Idle)	mA	40	40
Operation	A	≤ 2.4	≤ 2.4
Water protection <sup>9)</sup>	IP	X5D	X5D

- 1) These flow rates are based upon setting the unit to higher temperatures and then mixing down using cold water after the unit.
- 2) Input rating is based on sea level operation and need not be changed for operation up to 2000 ft (610 m) elevation. For operation at elevations above 2000 ft (610 m), input rating is automatically reduced at the rate of 4 percent for each 1000 ft (305 m) above sea level.
- 3) When converted to LPG the minimum input is 17 000 BTU/hr (5 kW).
- 4) With constant flow.
- 5) Can be programmed to achieve 140 °F (60 °C) (see chapter 6.4).
- 6) Requirements: Steady flows, single unit installations, up to 140 °F (60 °C).
- 7) To measure Gas Pressure, see Measuring Gas Pressure, chapter 4.17, page 29.
- 8) Activation varies with inlet water temperatures. Deactivation point value is 0.35GPM (1.3 l/min).
- 9) Protection against water spray.

Table 3

### Safety devices

- Flame failure device (flame detection via ionization rod)
- Overheat prevention
- Inlet water temperature sensor
- Outlet water temperature sensor
- Exhaust flue gas temperature sensor
- Water flow sensor
- Air flow sensing technology (Combustion Management System)
- Scaling detection sensor (HE flue gas temperature sensor)

### 3.3 Unpacking the heater

The heater is default-set by the manufacturer to operate with Natural Gas, for use with Liquid Propane, follow the conversion instructions in section 6.7.1.

Before installing the unit, be certain you have the heater correctly set for your type of Gas - Propane or Natural Gas. Identification labels are found on the shipping box, and on the rating plate which is located on the left side (when facing appliance front) of the cover.

MODEL # / N° DE MODELE [ ]

ORDER # / N° DE COMMANDE [ ]

FD # / N° DE SERIE [ ]

AUTOMATIC INCENTIVIZED WATER HEATER / CHAUFFE EAU INCENTIVE ADAPTÉ  
 AND ZERO-ENERGY READY / CHAUFFE EAU ZÉRO ÉNERGIE PRÊT À L'EMPLOI  
 CSA #3 2001

FOR OPERATION AT INLET WATER TEMPERATURE OF 140°F / À LA DÉMARRAGE  
 SOURCE À UNE PRESSION HYDROSTATIQUE MAX. 200 psi / PRESSION HYDROSTATIQUE DE FONCTIONNEMENT 150 psi

POUR LE FONCTIONNEMENT À UNE TEMPÉRATURE DE 140°F À LA DÉMARRAGE  
 SOURCE À UNE PRESSION HYDROSTATIQUE MAX. 200 psi / PRESSION HYDROSTATIQUE DE FONCTIONNEMENT 150 psi

RATINGS AT ALTITUDE / ÉVALUATION À DIFFÉRENTE ALTITUDE	
MAX. INPUT BTU/H	CONSUMATION MAX. BTU/H
MIN. INPUT BTU/H	CONSUMATION MIN. BTU/H
REG. RATING, U.S.S. GAL/MIN.	RECOMMANDÉ U.S.S. GAL/MIN.
ORIFICE SIZE	TAILLE DES ORIFICES
INLET PRESS., IN W.C.	PRESSION D'ENTRÉE EN Po
VENT. DIM., INCHES	DIAMÈTRE DU CONDUIT DE CHEMINÉE
MIN. GAS SUPPLY PRESS., IN W.C.	LA PRESSION MINIMUM DU GAZ EN Po

FOR PURPOSE OF RATE ADJUSTMENT / POUR RAISON D'AJUSTEMENT

SUITABLE FOR WATER DISTRIBUTION / CONVIENT POUR RÉSEAU D'EAU FROID / FROID

TYPE OF GAS [ ]

TYPE DE GAZ [ ]

MAX. GAS PRESS. / MAX. GAZ FURNED EST DE 3.7 MPa (1/2 PSI)

6720080030-15, 1V

Fig. 2 Rating plate

- [1] Serial number
- [2] Type of gas (Natural gas by default)

#### 3.3.1 The box includes

- Water Heater
- LP conversion kit
- Bracket and screws for wall hanging the heater
- Installation manual (manual can be downloaded at [www.bradfordwhite.com](http://www.bradfordwhite.com))

The RTG-K-199/160N/X2 is not approved or designed for:

- **Manufactured (mobile) homes, boats or any mobile installation. (Modular homes are acceptable for installation).**
- **Use above 8000 ft A.S.L. altitude.**
- **Applications where inlet water temperature is higher than 140°F (60°C) for Residential appliances.**  
 In these applications a 3 way valve or thermostatic mixing valve must be installed before the appliance's water inlet connection.
- **Use with commercial dishwasher pre rinse spray valves.**
- **Booster applications.**



In preheated inlet water applications (i.e. solar preheat), activation flow rate will vary depending upon the unit set point, inlet water temperature and the demand flow rate thru the unit. Please consult your original installer for further details to determine if this will function in your application.

#### 3.3.2 Remove front cover

- ▶ Loosen two Phillips head screws located on bottom of cover, fig. 3.

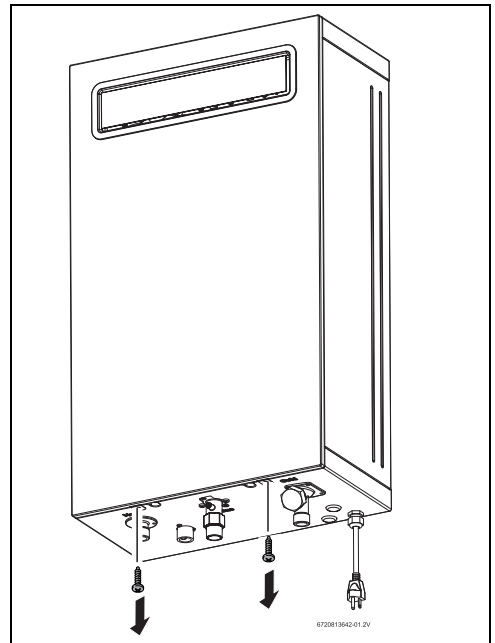

Fig. 3 Loosen two Phillips head screws

- ▶ Lift the front cover to remove from the appliance.
- ▶ Install the appliance vertically with the plumbing connections facing the ground.

### 3.4 General rules to follow for safe operation

#### **Warning: Safety Rules!**

1. You must follow these instructions when you install your heater. In the United States: The installation must conform with local codes or, in the absence of local codes, the National Fuel Gas Code ANSI Z223.1/NFPA 54.  
In Canada: The Installation must conform with CSA B149.(1,2) INSTALLATION CODES and /or local installation codes.
2. Carefully plan where you install the heater. Correct combustion air supply and vent pipe installation are very important. If not installed correctly, fatal accidents can occur, such as carbon monoxide poisoning or fire.
3. The water heater must be installed outdoors.
4. The appliance and its gas connection must be leak tested before placing the appliance in operation.  
The appliance must be isolated from the gas supply piping system by closing its individual manual gas shutoff valve (not supplied with heater) during any pressure testing at pressures in excess of  $\frac{1}{2}$  Psig (3.5 kPa).
5. Keep water heater area clear and free from combustibles and flammable liquids. Do not locate the heater over any material which might burn.
6. **Correct gas pressure** is critical for the proper operation of this heater. Gas piping must be sized to provide the required pressure at the maximum output of the heater, while all the other gas appliances are in operation. Check with your local gas supplier, and see section 4.8 on connecting the gas supply.
7. Should overheating occur or the gas supply fail to shut off, turn off the gas supply at the manual gas shut off valve, on the gas line. Note: manual gas shutoff valve is not supplied with the heater but must be field installed.
8. Do not use this appliance if any part has been underwater. Immediately call the person responsible for the installation of your appliance to inspect the appliance and to replace any part of the control system and any gas control which has been underwater.
9. Failure to install the heater correctly may lead to unsafe operation.

## 3.5 Dimensions

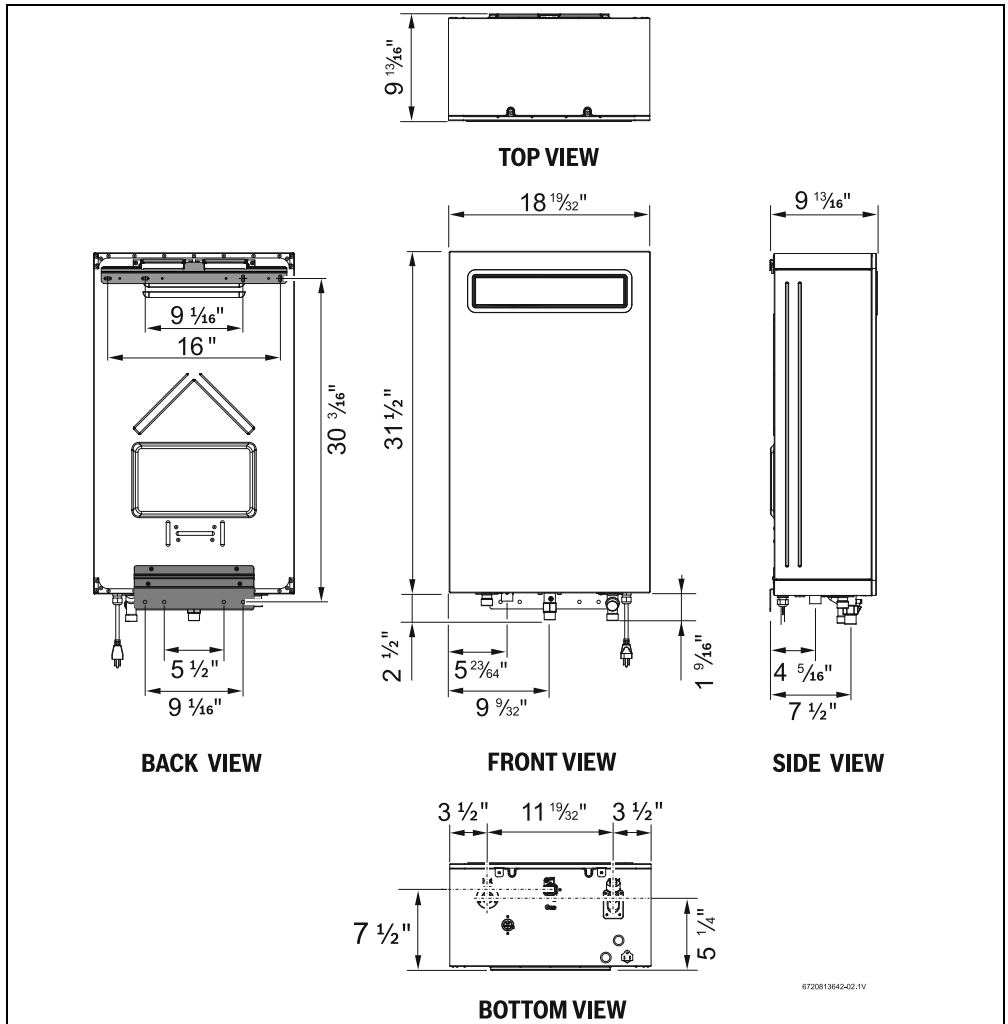

Fig. 4 Dimensions

## 4 Installation instructions

### 4.1 Installation tools

The following specialized tools may be required if converting from natural gas to LP:

- Pressure manometer

### 4.2 Introduction

**Please follow these instructions. Failure to follow instructions may result in:**

- ▶ Damage or injury.
- ▶ Improper operation.
- ▶ Loss of warranty.



#### **DANGER:**

- ▶ The water heater must be installed by a qualified installer in accordance with these instructions. If improperly installed, a hazardous condition such as explosion or carbon monoxide poisoning could result. Bradford White is not responsible for improperly installed appliances.



Common installation practice is to first determine the installation location, then design the piping layout.

### 4.3 Proper location for installing your heater

Carefully select the location of the water heater. For your safety and for proper heater operation, you must not block or obstruct combustion air to the heater.

Follow the guidelines below:

1. Locate the heater where gas and plumbing connections are feasible and convenient.
2. The hot water lines should be kept short and insulated to save energy. It is recommended to locate the water heater as close as practical to the most frequently used hot water fixtures.
3. In areas where outside temperatures are below 32°F (0°C) water pipes should be properly insulated, to maintain water temperature and prevent freezing.
4. In dusty areas, the appliance should be protected from particles that may enter with combustion air to avoid premature malfunction or failure of the heater.

#### **NOTICE:**

##### **Risk of appliance freezing!**

- ▶ The water in this water heater is cold and always remains cold except for the times the burner is on. In the event of power outage in conjunction with freezing temperatures, the heater should be drained.  
See chapter 7.2, page 41 “Winterizing” for draining instructions.



#### **WARNING:**

- ▶ Flammable materials, gasoline, pressurized containers, or any other items or articles that are potential fire hazards must NOT be placed on or adjacent to the heater. The appliance area must be kept free of all combustible materials, gasoline and other flammable vapors and liquids.



#### **WARNING:**

##### **Risk of blockage!**

- ▶ Excess of solid particles (e.g. bugs, pollen) in the air intake may clog the air filter and lead to premature failure of the heater if not protected accordingly.
- ▶ Do not install the water heater in areas where chemicals like hair sprays, spray detergents, chlorine, or similar chemicals may accumulate.

### 4.4 Selecting heater location

- ▶ Choose an outside wall for the installation. Installation on a wall protected by an overhang above is recommended.
- ▶ Install the water heater above anticipated snow level.

#### **Minimum clearances**

If the appliance is installed under an overhang, there must be a 36" clearance from the top of the appliance and the mounting area must be open in front and on the sides of the appliance.



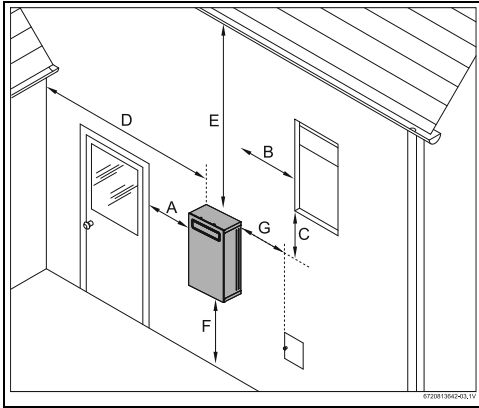

Fig. 5

Ref	Description	Min. distances
A	Directly below or adjacent to an opening;	1 ft
B	operable windows, doors and any fresh air	
C	openings	
D	From any adjacent wall	1 ft
E	Below a gutter, sanitary pipework, eaves or overhang	3 ft
F	Above ground	1 ft
G	From a gas meter or gas regulator	3 ft

Table 4

#### 4.5 Mounting instructions

- ▶ The water heater is approved for installation directly on an outside wall. Secure the wall mounting bracket provided with the water heater to a wall surface. See fig. 6.

- ▶ The installation method of the mounting bracket will depend on the type of mounting surface. Due to the varieties of building siding or surfacing, the installer must decide on how best to support and level the heater on an outside wall. It is recommended that horizontal or vertical support boards or plywood sheathing (½" minimum) first be attached to the wall surface. The heater must be kept level on the wall surface.

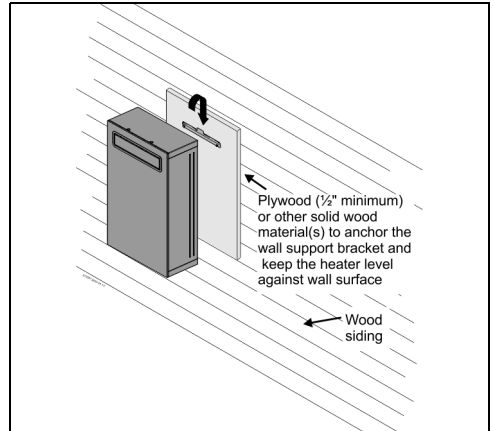

Fig. 6 Installation on wood siding

## Installation instructions

### 4.5.1 Air openings

Air openings are located on the back of the water heater. The combustion air enters between the mounting surface and the water heater.

- ▶ Do not restrict air intake openings in any way.
- ▶ Keep water heater sides clear and unblocked.

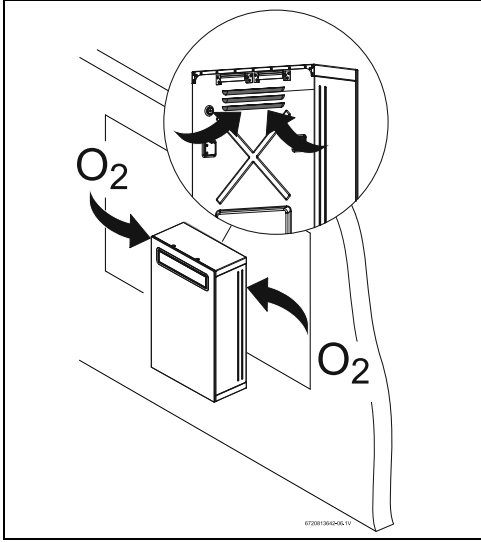

Fig. 7 Air openings

### 4.6 Factory regulation

The appliances are supplied having been set in the factory for the values shown on the rating plate for natural gas. For any other adjustments see chapter 7.

#### 4.6.1 Natural gas



The appliances must not be operated if the dynamic gas pressure is less than 3.5" WC or greater than 10.5" WC.

#### 4.6.2 Liquid propane gas (after gas conversion)



The appliances must not be operated if the dynamic gas pressure is less than 8" WC or greater than 13" WC.

If gas conversion is needed (Natural Gas to Liquid Propane gas), see section 6.7.1.



### DANGER:

- ▶ The gas type conversion must only be carried out by a qualified contractor.

### 4.7 Mounting installation for modular homes

When installing this appliance on the outside of a modular home, the unit must be additionally secured at the bottom of the water heater as shown in fig. 8. Use the included screws to secure the brackets at the bottom of the water heater to the wall. If the wall is sheathed with plaster or drywall, it is recommended that a support board be first attached across a pair of studs at the bottom of the unit.

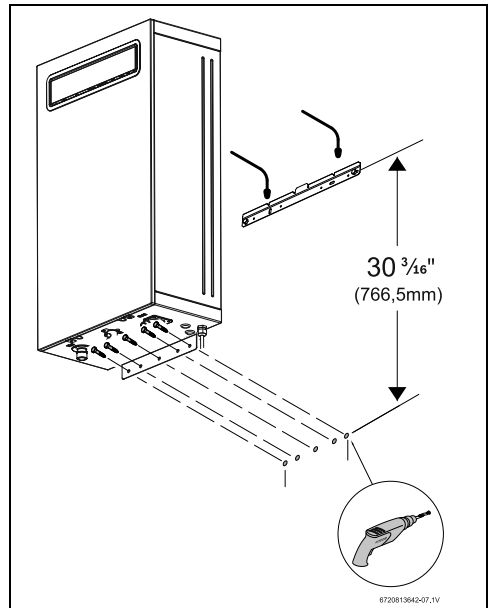

Fig. 8 Mounting the heater on modular homes

### 4.8 Gas piping & connections



Before connecting the gas supply, check the rating plate on the right side of the heater to be sure that the heater is rated for the same gas to which it will be connected.

In the United States: The installation must conform with local codes or, in the absence of local codes, the National Fuel Gas Code ANSI Z223.1/NFPA 54.

In Canada: The Installation must conform to CGA B149 INSTALLATION CODES and/or local installation codes.



**DANGER:**

**Explosion hazard!**

- ▶ DO NOT connect to an unregulated or high pressure propane line or to a high pressure commercial natural gas line.



**DANGER:**

**Explosion hazard!**

- ▶ The heater must be isolated from the gas supply piping system during any pressure testing of that system at test pressures equal to or more than 0.5 psig (14" W.C.). If overpressure has occurred, such as through improper testing of the gas lines or malfunction of the supply system, the gas valve must be checked for safe operation.

**GAS CONNECTIONS**

- ▶ Install a manual gas shut off valve within easy reach of the appliance.
- ▶ Install a union when connecting the gas supply.
- ▶ Gas connection to the water heater is 3/4" NPT. See chapter 4.8.1 for the minimum internal pipe diameter required.
- ▶ Undersized flexible appliance connector is not permitted.
- ▶ National Fuel Gas Code requires that a sediment trap (drip leg) be installed on gas appliances not so equipped. The drip leg must be accessible and not subject to freezing conditions. Install in accordance with the recommendations of the serving gas supplier, see fig. 10.
- ▶ Tighten gas pipe with the support of a wrench, see fig. 9.

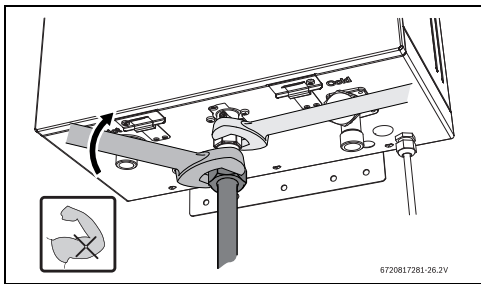

Fig. 9 Tighten gas pipe to the heater

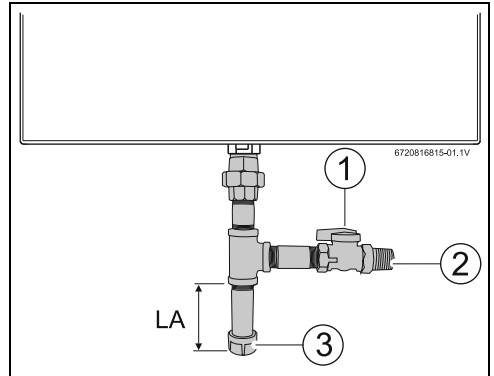

Fig. 10 Gas connection

- [1] Shut off valve
- [2] Gas supply line
- [3] Cap
- [4] Minimum 3" sediment trap, (drip leg)

Once connections are made, check for gas leaks at all joints. Apply some gas leak detection solution to all gas fittings. Bubbles are a sign of a leak. A combustible gas detector may also be used to detect for leaks.



**DANGER:**

**Explosion hazard!**

- ▶ If you detect a leak, shut off the gas. Tighten appropriate fittings to stop leak. Turn the gas on and check again with a gas leak detection solution. Never test for gas leaks using a match or flame.

**GAS LINE SIZING**

The gas supply piping for a single heater should be sized for a maximum draw of 160 000 BTU/hr /199 000 BTU/hr for the RTG-K-199/160N/X2. Measure the length of the gas supply line from the building's gas main to the heater and use section 4.8.1, page 20 or the gas line manufacturer's sizing tables to determine the pipe diameter necessary. If there are more gas consuming appliances on the line, size the gas line according to the total maximum BTU input rating for all appliances combined.

**Note:** Undersizing the gas line may result in diminished hot water flow rate and temperature. See chapter 4.17, page 29 for the procedure to measure gas pressure. Proper gas pressure must be confirmed at time of installation.

## Installation instructions

### 4.8.1 Gas Line Sizing Tables for NATURAL GAS

For your convenience, see below for an excerpt from gas line sizing tables for a single NG appliance. For details, see the current NFPA 54.

Required input for 160 000 / 199 000 BTU/hr for the RTG-K-199/160N/X2. The gas supply system must be sized for the combined total maximum BTU/hr load requirements of all gas appliances running simultaneously.

The tables below show the maximum capacity of the gas supply pipe in cubic feet per hour. Please contact your local gas supplier for the energy content of the gas to determine the BTU/hr capacity. Use 1,000 BTU/cubic foot for rough estimations.

Nominal Iron Pipe Size, inches	Internal Diameter inches	Length of Black Iron Pipe (Schedule 40 Metallic Pipe), Feet									
		10	20	30	40	50	60	70	80	90	100
¾	0.824	360	247	199	170	151	137	126	117	110	104
1	1.049	678	466	374	320	284	257	237	220	207	195

Table 5 Maximum pipe capacity in cubic feet of Natural Gas per hour for gas pressures of <2.0 psig (55" WC or 138 mbar) and a pressure drop of 0.5" W.C. (1.25 mbar) based on 0.60 specific gravity gas)

Initial Supply Pressure of 8.0" w.c. or Greater											
Nominal Iron Pipe Size, inches	Internal Diameter inches	Length of Black Iron Pipe (Schedule 40 Metallic Pipe), Feet									
		10	20	30	40	50	60	70	80	90	100
½	0.622	454	312	250	214	190	172	158	147	138	131
¾	0.824	949	652	524	448	397	360	331	308	289	273
1	1.049	1790	1230	986	844	748	678	624	580	544	514

Table 6 Maximum pipe capacity in cubic feet of Natural Gas per hour for gas pressures of <2.0 psig (55" WC or 138 mbar) and a pressure drop of 3.0" W.C. (7.5 mbar) based on 0.60 specific gravity gas)

Length of Corrugated Stainless Steel Tubing (CSST), Feet										
EHD*	10	20	30	40	50	60	70	80	90	100
30	330	231	188	162	144	131	121	113	107	101
31	383	269	218	188	168	153	141	132	125	118
37	639	456	374	325	292	267	248	232	219	208

Table 7 Maximum pipe capacity in cubic feet of Natural Gas per hour for gas pressures of <2.0 psig (55" WC or 138 mbar) and a pressure drop of 0.5" W.C. (1.25 mbar) based on 0.60 specific gravity gas)

\* EHD = Equivalent Hydraulic Diameter. The greater the value of EHD, the greater the gas capacity of the tubing.

### 4.8.2 Gas Line Sizing Tables for LP GAS

For your convenience, see below for an excerpt from gas line sizing tables for a single LP appliance. Their intended use is for pipe sizing between the 2nd stage (low pressure) regulator and the appliance. For details, see the current NFPA 54.

Required input for 160 000 / 199 000 BTU/hr for the RTG-K-199/160N/X2. The gas supply system must be sized for the combined total maximum BTU/hr load requirements of all gas appliances running simultaneously.

Pipe Sizing Between Single- or Second-Stage (Low-Pressure) Regulator and Appliance									
Nominal Iron Pipe inches	Internal Diameter inches	Length of Black Iron Pipe (Schedule 40 Metallic Pipe), Feet							
		10	20	30	40	50	60	80	100
1/2	0.622	291	200	160	137	122	110	101	94
3/4	0.824	608	418	336	287	255	231	212	197
1	1.049	1150	787	632	541	480	434	400	372

Table 8 Maximum capacity of the gas supply pipe in thousands of BTU per hour of Undiluted LP Gas at 11" W.C. (0.4 psig or 27.4mbar) based on a pressure drop of 0.5" W.C. (1.25mbar)

CSST Sizing Between Single - or Second -Stage (Low-Pressure) Regulator and Appliance Shutoff Valve										
EHD <sup>1)</sup>	Length of Corrugated Stainless Steel Tubing (CSST), Feet									
	10	20	30	40	50	60	70	80	90	100
23	254	183	151	131	118	107	99	94	90	85
25	303	216	177	153	137	126	117	109	102	98
30	521	365	297	256	227	207	191	178	169	159
31	605	425	344	297	265	241	222	208	197	186

1) EHD = Equivalent Hydraulic Diameter. The greater the value of EHD, the greater the gas capacity of the tubing.

Table 9 Maximum capacity of the gas supply pipe in thousands of BTU per hour of Undiluted LP Gas at 11" W.C. (0.4 psig or 27.4mbar) based on a pressure drop of 0.5" W.C. (1.25mbar)

Tube Sizing Between Single- or Second-Stage (Low-Pressure) Regulator and Appliance						
Nominal tube inches	Internal Diameter inches	Length of Semirigid Copper Tubing, Feet				
		10	20	30	40	50
1/2	0.527	188	129	104	89	79
5/8	0.652	329	226	182	155	138

Table 10 Maximum capacity in thousands of BTU of the gas supply pipe per hour of Undiluted LP Gas at 11" W.C. (0.4 psig or 27.4mbar) based on a pressure drop of 0.5" W.C. (1.25mbar).

### 4.9 Water quality

Water quality can have an impact on appliance longevity. Water supplied to the RTG-K-199/160N/X2 must be in accordance with table 11 and fig. 11.

For water analysis data call your local water department, or if on a well, have well water analyzed periodically. Heavy scale will form if the combination of water total hardness and pH exceeds the values specified in fig. 11 (grey area), Bradford White recommends consulting a local water treatment professional for water softening/conditioning options.

Description	Max. Levels	
pH	pH	6.5 - 8.5
TDS (total Dissolved Solids)	mg/l or ppm	690
Total hardness	mg/l or ppm	200
Aluminum	mg/l or ppm	2.0
Chlorides	mg/l or ppm	250
Copper	mg/l or ppm	1.0
Iron	mg/l or ppm	0.3
Manganese	mg/l or ppm	0.05
Zinc	mg/l or ppm	5.0

Table 11 Water Quality

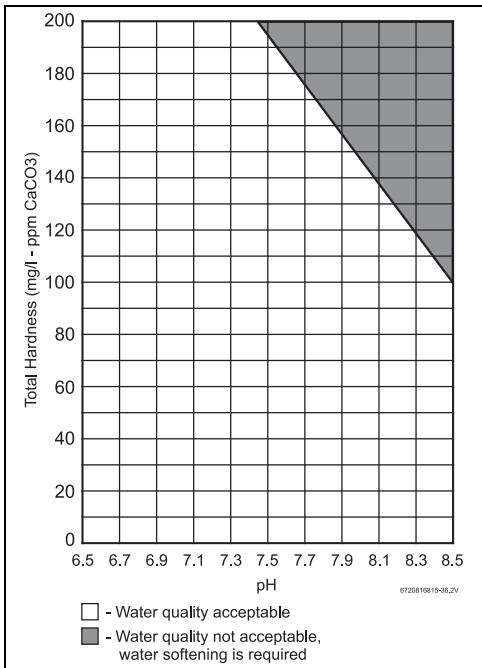

Fig. 11 Water total hardness and pH values

1. Total Hardness and pH maximum values must be evaluated in combination. Indicated maximum values will be reduced according to fig. 11.
2. Combined values of total hardness and pH must be under the indicated grey area. (e.g. the pair [180;8.3] [total hardness; pH] is not acceptable).

### 4.10 Water connections



**NOTICE:**

- ▶ This heater is not approved for preheated water applications exceeding 140 °F (60 °C) for Residential appliances, in these cases use a 3-way valve or mixing valve must be installed before the appliance to prevent water exceeding 140 °F (60 °C) for Residential appliances from entering the appliance.
- ▶ When facing the heater, the 3/4" cold connection is on the bottom right and the hot connection is on the bottom left.
- ▶ Tighten all water connections with the support of a wrench, see Fig. 12.

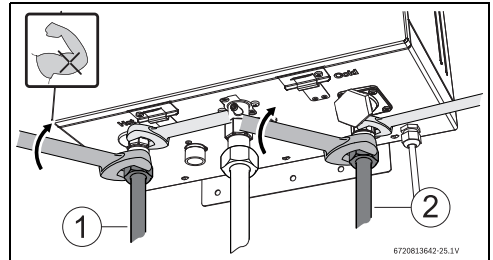

Fig. 12

- [1] Hot connection
- [2] Cold connection

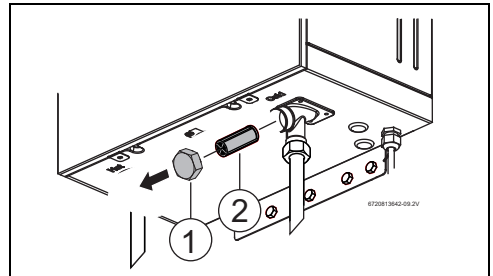

Fig. 13 Water filter

- [1] Cap
- [2] Water filter



**WARNING:**

**Appliance damage!**

Appliance will overheat if not filled with water

- ▶ Ensure that the appliance is filled with water by opening a hot water faucet, before plugging in the water heater to the power supply.

- ▶ The use of unions when connecting water pipes to the inlet and outlet connections is required. This will facilitate any necessary servicing.
- ▶ Plastic or PEX type plumbing line materials are not suitable for connecting directly to or within an 18" pipe run of the water heater.
- ▶ Although water piping throughout the building may be other than copper, we recommend that copper or suitably rated stainless steel flex line be used for the water connections for 1.5' on either side of the water heater (follow local codes if more stringent).
- ▶ Never sweat any piping directly to or beneath the water connections, as damage will occur to the internal water valve from heating of the pipe.
- ▶ Keep water inlet and outlet pipes to no less than 3/4" (19.05mm) diameter to allow the full flow capacity.
- ▶ If the cold and hot connections to the heater are reversed, the heater will not function.
- ▶ Be certain there are no loose particles or dirt in the piping. Blow out or flush the lines before connecting to the water heater.
- ▶ Full port shutoff valves should be installed on both the cold water supply and hot water outlet lines to facilitate servicing the heater (see fig. 14).
- ▶ For installation on a private well system with the use of a pressure tank, the lowest pressure range setting recommended is 30 psi (2.06 bar) to ensure optimal performance.
- ▶ Proper insulation material should be used in places prone to freezing conditions.

**Connecting the pressure relief valve (PRV)**

A pressure relief valve must be installed at the time of installation. No valve is to be placed between the PRV and the heater. No reducing coupling or other restriction may be installed in the discharge line. The discharge line must be a minimum of 4" above a drain and installed such that it allows complete drainage of both the PRV and the line. The discharge line must be placed where it will not cause any damage. The location of the PRV must be readily accessible for servicing or replacement, and be mounted as close to the water heater as possible. See fig. 14. To install the PRV, a suitable fitting

connected to an extension on a "T" fitting can be connected to the hot water line.

- ▶ Support all piping.

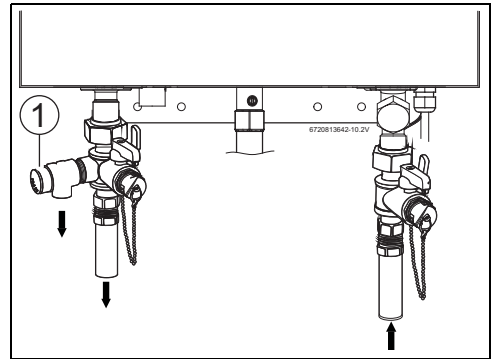

Fig. 14 Plumbing Connections (with shutoff valves) and Pressure Relief Valve

- [1] Pressure relief valve

**4.11 Connecting the condensate water drain**

**NOTICE:**

**Risk of condensate pipe freezing!**

- ▶ Do not install condensate drain tubing in areas where it may freeze.

**Appliance condensate drain installation**

The appliance comes equipped with an internal condensate drain and siphon. This drains condensation formed in the secondary heat exchanger. Piping must be installed under the condensate drain outlet on the water heater and piped for disposal in accordance with local codes.

To install the condensate drain, connect a 3/8"NPT adapter on the water heater. Use only Teflon tape. Do not block vacuum relief opening.

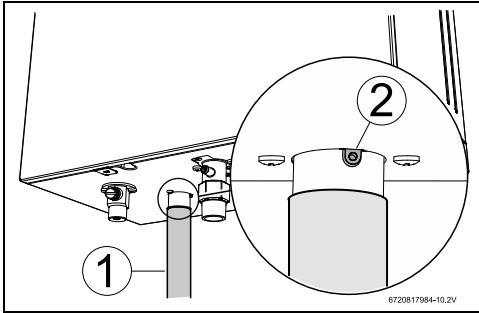

Fig. 15 Appliance drain installation

- [1] Condensate drain connection
- [2] Breather

Installing an additional breather downstream is not necessary since this function is already included in the heater.

**NOTICE:**

**A blocked breather will prevent siphon from draining.**

- ▶ Ensure that the vacuum relief opening included in the siphon is not obstructed (for example with pipe dope) to allow correct function.



Verify condensate disposal/neutralization is in accordance with federal, State, and local regulation.



This is a high efficiency appliance; condensate flow can be as much as 2.1 gal/hr at full power.

**4.12 Domestic hot water recirculation with external pump**

The following drawings are provided to illustrate possible recirculation designs. This schematic is for illustration only and must not be used for actual installation without appropriate engineering and technical advice from a properly licensed professional in the locality where the installation is made.



Recirculation menus for RTG-K-199/160N/X2 are only available with the Bradford White remote control (TTNR).

This appliance has been designed to permit recirculation by controlling an external pump. For this function a cable has been provided to electrically connect the external pump to the appliance. All the features of recirculation (→ section 6.5.4 **A1 Recirculation**) can be used. Please be aware that the cable does not provide 120 VAC to operate the recirculation pump, it is a dry-contact switching external voltage of up to a maximum of 5 amps.

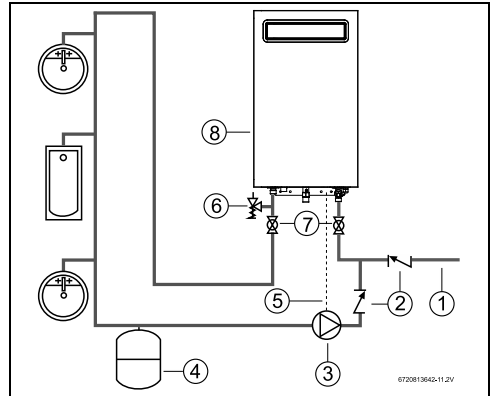

Fig. 16 Recirculation application with a dedicated return line

- [1] Cold water supply
- [2] Check valve field supplied
- [3] Circulator pump (field supplied)
- [4] Expansion tank (field supplied)
- [5] Circulator cable accessory
- [6] PRV
- [7] Shutoff valves (field supplied)
- [8] RTG-K-199/160N/X2

**4.13 Adjusting the recirculation settings**

The pump and burner turn ON and OFF based on a delta between the set point temperature on the water heater and the inlet water temperature sensor value. This delta is called the **comfort level**.

The higher the comfort level, the smaller the delta between the set point temperature on the water heater and the inlet water temperature sensor value, resulting in a hotter recirculation system.

The smaller the comfort level, the larger the delta between the set point temperature on the water heater and the inlet water temperature sensor value, resulting in a cooler recirculation system.

Below is a graph illustrating how the comfort level value changes the recirculation system's temperature.



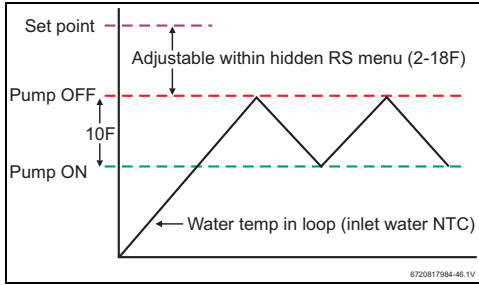

Fig. 17 Pump activation and deactivation thresholds

Comfort level	Delta T (°F)
1	18
2	16
3	14
4	12
5	10
6	8
7	6
8	4
9	2

Table 12 RS Menu

The **comfort level** can be adjusted to achieve the desired balance between readiness of hot water at the point of use and energy consumption.



A higher comfort level will result in longer pump run times, which will consume more electricity and gas.

#### 4.14 Recirculation with the RTG-K-160/199N/X1

Recirculation with the RTG-K-160/199 models requires the installation of an external pump.

The RTG-K-160/199 models have the capability of controlling an external pump by switching power ON and OFF to the external pump using the recirculation pump cable.



Use only bronze or stainless steel pumps. Do not use pumps of iron construction as they will oxidize and pose health risks.

Refer to pump manufacturers pressure vs flow specifications to select a pump that will provide adequate flow through the recirculation system.

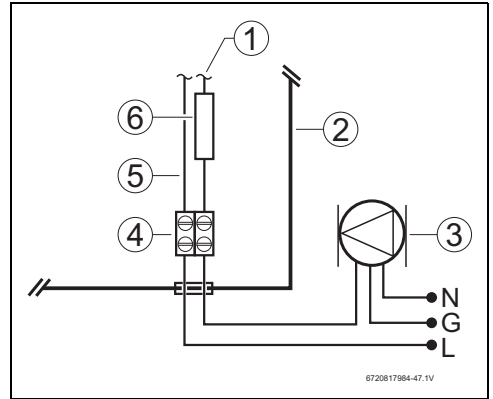

Fig. 18

- [1] Cable to control board
- [2] Appliance front cover
- [3] External recirculation pump (field supplied)
- [4] Terminal block
- [5] Recirculation pump cable
- [6] 5 amp fuse

The flow rate through the recirculation system must be larger than the activation flow rate of the water heater, 0.4 GPM.

A flow rate through the recirculation system greater than 1GPM is recommended.

#### 4.15 Cascading Operation

Cascading allows up to twenty four appliances to be connected in parallel. One of the appliances will serve as the controlling primary appliance and will attempt to meet the hot water demand. If the hot water demand is beyond the capacity of the primary appliance, a signal is sent to one or more of the secondary appliances to ignite. A cascading kit must be installed for each secondary appliance included in the installation.

**Example:** A 7 unit cascade installation includes 1 primary appliance and 6 secondary appliances. 6 intelligent cascading kits must be installed for this application.

##### 4.15.1 Plumbing set up

The plumbing should be connected in the reverse return method with a minimum number of elbows to aid in balancing pressures between the appliances. Locating the appliances as close as possible improves performance.

- Follow industry plumbing practices when installing multiple appliances.
- Minimum pipe diameter: ¾"
- Minimum water pressure: 50 psi
- Maximum distance between appliances: 36"

## Installation instructions

- Insulate pipes to prevent heat loss

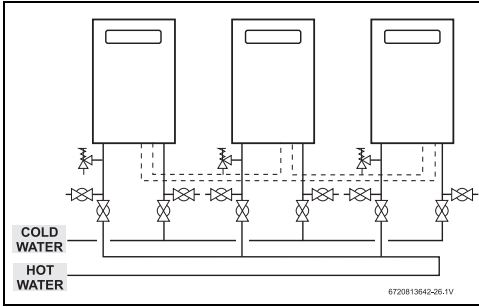

Fig. 19 Cascading installation example



It is not possible to have both cascading and recirculation active at the same time.



It is not possible to cascade a RTGK with a RTGL.

### 4.16 Space heating applications



#### WARNING:

- ▶ If the set point temperature is above 120°F (49 °C), precautions should be taken to protect users of potable water from scalding.

#### NOTICE:

- ▶ The use of a flow switch is recommended to ensure DHW priority and to prevent “cold-blow” situations when the Bosch tankless water heater is used with an air handler. Air handler installation must include a pump. The flow switch should be used to disable the blower on the air-handling system when domestic water is used.

#### NOTICE:

- ▶ Ensure the primary pump is properly sized to provide adequate flow for the system heat load.



For external pump sizing please refer to the pressure drop curves, fig. 21. Also remember to account for system piping pressure loss. A minimum of 1.7 GPM is recommended to provide adequate flow through the water heater when determining the size of the primary pump.

#### **RTG-K-199/160N/X2 tankless water heaters are approved for use in combination DHW and space heating applications (open loop setup).**

These water heaters are not approved for use in space heating only applications (closed-loop setup). Bradford White supports applications of combination DHW and space heating in an open loop configuration if plumbed similar to fig. 20. Please see warranty document for additional details.

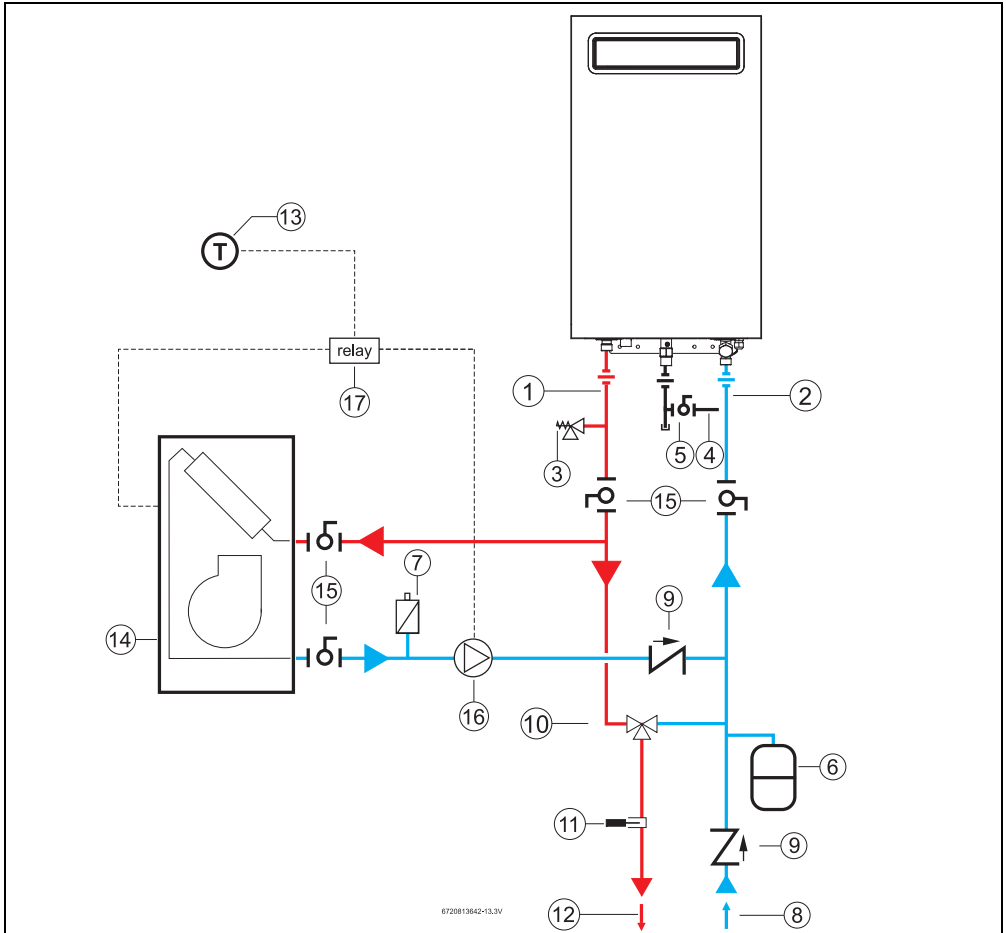

Fig. 20 Hydronic air system with Air Handler

- |   |  |
|---|--|
| [1] Hot water outlet  | [14] Air handler   |
| [2] Cold water inlet  | [15] Shutoff valve   |
| [3] Pressure relief valve   | [16] Circulation pump (only required if air handler doesn't include internal pump) |
| [4] Gas supply  | [17] Control relay (if not included within air handler)                            |
| [5] Shut off gas valve  |  |
| [6] Thermal expansion tank (as required)                              |  |
| [7] Air purge   |  |
| [8] Cold inlet  |  |
| [9] Check valve   |  |
| [10] Thermostatic mixing valve  |  |
| [11] Thermometer (optional)   |  |
| [12] DHW outlet   |  |
| [13] Thermostat (only valid if air handler includes an internal pump) |  |

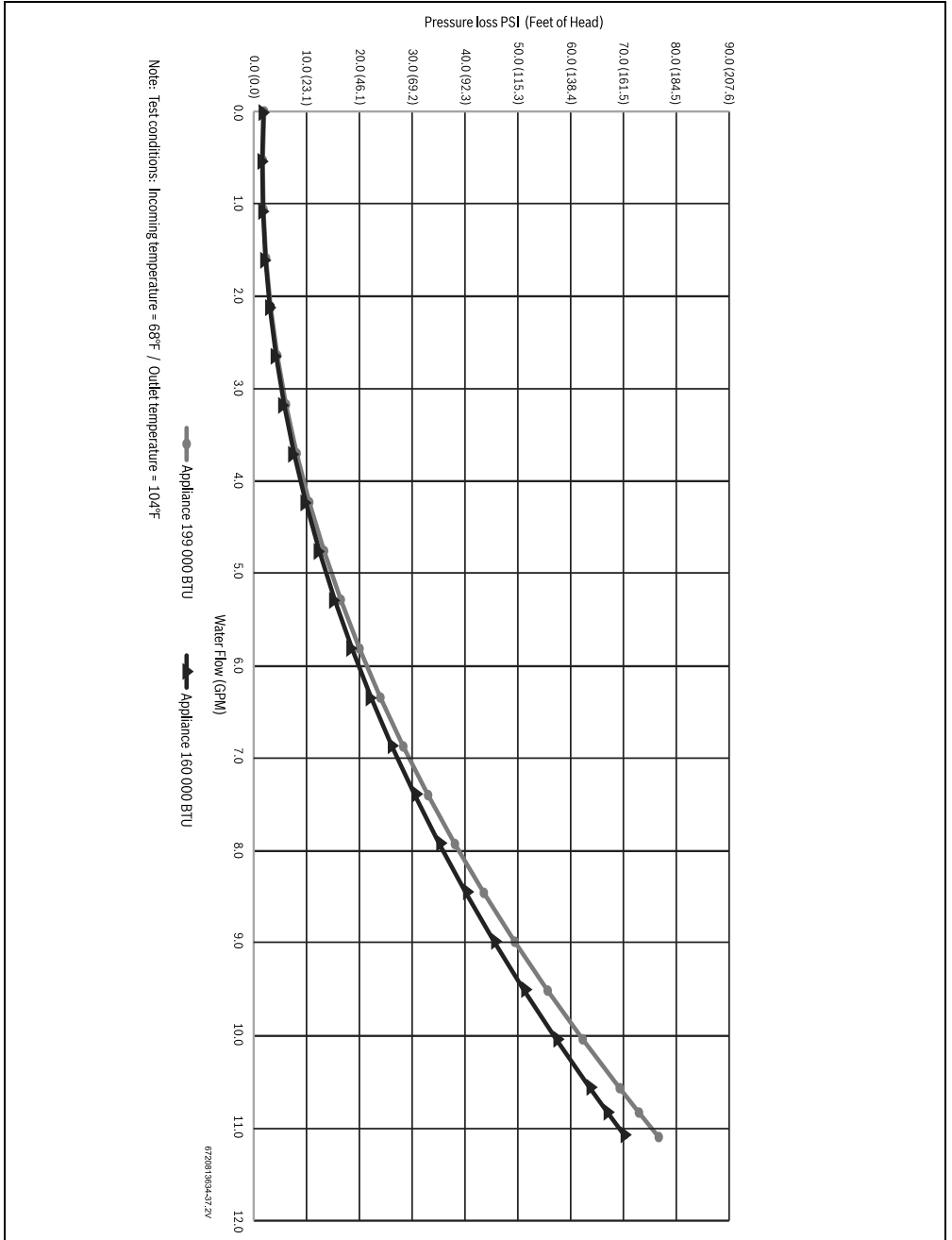

Fig. 21 Pressure drop curve

## 4.17 Measuring gas pressure

### 4.17.1 Gas supply pressure

Confirm gas pressure upon installation.

#### Connecting manometer

- ▶ Shut off gas supply at installer supplied shutoff valve for this water heater.
- ▶ Locate the inlet gas pressure test port (see Fig. 22).
- ▶ Loosen the screw inside test port fitting (do not remove) and connect the manometer tube to the test port (see fig. 22).

#### Static Pressure Test

- ▶ Turn the gas supply back on.
- ▶ Record the static gas pressure reading in table 14.

#### Dynamic Pressure Test

- ▶ Turn ON the appliance.
- ▶ Access menu **P1 Max. Power**, see chapter 8.11.2.

Note: While in this mode the appliance will run constantly at maximum power and allow maximum water flow.

For inlet gas pressure adjustment consider the following table:

Gas type	NG	LPG
Inlet gas pressure	3.5" WC	8" WC

Table 13 Minimum inlet gas pressure under full operation

- ▶ Operate all other gas appliances (except heater) on the same gas piping system at maximum output.
- ▶ Open all hot water faucets to achieve a flow rate of at least 6 gallons per minute. (1 tub and 2 sinks should be sufficient). If heater goes back to P2, open more hot water fixtures to allow sufficient flow and access to P1.
- ▶ Record the lowest operating gas pressure reading in table 14.
- ▶ Turn OFF the appliance.
- ▶ Shut off gas supply.
- ▶ Disconnect the manometer tube from the test point.
- ▶ Tighten the screw inside test point fitting.

Gas pressures lower than 3.5" W.C. or 8" W.C. for LPG for Natural Gas may result in reduced power output.

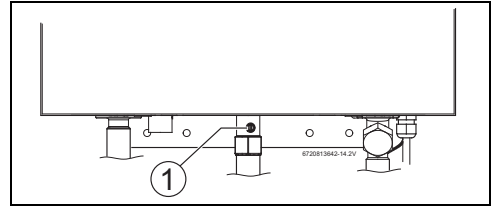

Fig. 22 Gas pressure test port

[1] Gas pressure measuring point

	Gas pressure	Date
Static Gas Pressure Reading		
Dynamic Gas Pressure Reading		

Table 14 Inlet gas pressure readings

## 5 Electrical connections

### 5.1 Electrical power supply



#### WARNING:

- ▶ For safety reasons, disconnect the power supply cord to the water heater before any service or testing is performed.



#### WARNING:

- ▶ For safety reasons install a proper waterproof outlet.



#### DANGER:

- ▶ This water heater must be electrically grounded in accordance with the most recent edition of the National Electrical Code. NFPA 70. In Canada, all electrical wiring to the heater must be in accordance with local codes and the Canadian Electrical Code, CSA C22.1 Part 1. Do not rely on the gas or water piping to ground the metal parts of the heater.



**DANGER:**

### Electric shock!

- ▶ Field wiring connections and electrical grounding must comply with local codes, or in the absence of local codes, with the latest edition of the National Electric Code, ANSI/NFPA 70, or in Canada, all electrical wiring must comply with the local codes and the Canadian Electrical Code, CSA C22.1 Part 1.



**DANGER:**

### Electric shock!

Shock hazard: line voltage is present.

- ▶ Before servicing the water heater, unplug power supply cord from outlet. Failure to do so could result in severe personal injury or death.

The water heater requires an electrical power supply from a 120VAC / 60Hz properly rated receptacle and must be properly grounded.

The water heater is wired as shown in the wiring diagram (chapter 10, Fig. 52).

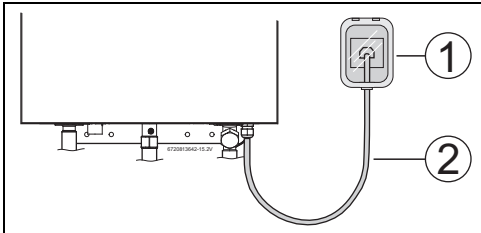

Fig. 23 Connecting power supply cord

- [1] Waterproof outlet
- [2] Power cord length: 5.9ft (1.8m).

Note: The power supply that the appliance is plugged into should be protected from possible water damage. Observe proper clearance to avoid damages.

## 5.2 Position of the fuses in control unit

To check the fuse, proceed as follows:

- ▶ Disconnect the appliance from the power supply before removing the front cover.
- ▶ Remove the front cover, see fig. 3, page 13.
- ▶ Remove the two phillips head screws securing the control unit.
- ▶ Disconnect all the cables from the control unit.

- ▶ Press the four snaps of the control unit and remove the cover.

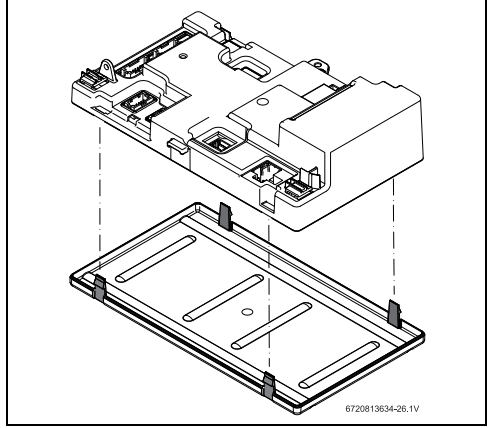

Fig. 24 Control Unit

- ▶ Press the four snaps inside the control unit and remove the PCB.
- ▶ Check the fuse on the printed circuit board for electrical continuity, see fig. 25, [1].

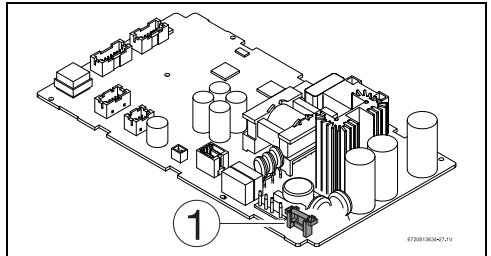

Fig. 25 Fuse position

- [1] Fuse
- ▶ After checking the fuse, reinstall all parts in reverse order.

## 6 Operating Instructions

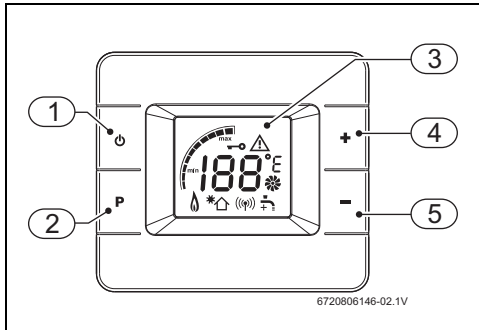

Fig. 26 Digital display

- [1] On/Off button
- [2] Programming button
- [3] LCD display
- [4] Increase / Enter button
- [5] Decrease / Return button

**NOTICE:**

- ▶ Do not use any aggressive or corrosive cleaning agents to clean the LCD display.

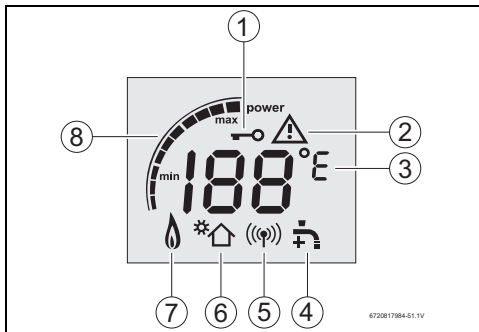

Fig. 27 Description LCD display

- [1] Locked condition indicator
- [2] Error indicator
- [3] Temperature indicator
- [4] Activation water flow
- [5] Cascading Primary indicator
- [6] Solar mode indicator
- [7] Flame indicator
- [8] Power bar indicator

### 6.1 For your safety read before operating your water heater



**WARNING:**

**Explosion hazard!**

- ▶ If you do not follow these instructions exactly, a fire or explosion may result causing property damage, personal injury or loss of life.

**NOTICE:**

**Appliance malfunction!**

Strong magnetic fields can interfere with the electronics, which can lead to appliance malfunction.

- ▶ Do not attach magnets to this water heater, do not install near strong magnetic fields.

**A.** This appliance is equipped with electronic ignition for lighting the main burner. When turning the heater on, follow these instructions exactly.

**WHAT TO DO IF YOU SMELL GAS**

- ▶ Turn off the gas shut-off valve.
- ▶ Open windows and door if smell detected inside the house.
- ▶ Do not try to ignite the appliance.
- ▶ Do not touch any electrical switch, telephone, and do not use outlets.
- ▶ Extinguish all open flames. Do not smoke! Do not use lighters!
- ▶ Warn all occupants of the building. Do not ring doorbells!
- ▶ If you can hear gas leaking, leave the building immediately.
- ▶ Prevent others from entering the building and notify the police and fire department from outside the building.
- ▶ From outside the building, call the gas utility company and a trained and certified installer.

**B.** Never use tools, close the gas supply and call a qualified service technician. Forceful repair may result in a fire or explosion.

**C.** Do not use this appliance if any part has been under water. Immediately call a qualified service technician to inspect the appliance and to replace any part of the control system and any gas control which has been under water.

### 6.2 Power

To turn ON the appliance:

To access appliance HMI, procedure as follows:

- ▶ Remove front cover, see fig. 3.
- ▶ Press the button .  
The display shows the desired water temperature.

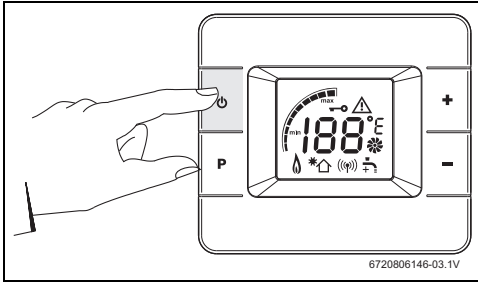

Fig. 28

To shut down the appliance:

- ▶ Press the button .

### 6.3 Error code reset

Some possible faults can be solved by resetting the appliance.

To remove an error code from the display,

- ▶ Press and hold button for more than 3sec.  
The appliance will initiate the start up sequence.



**WARNING:**

**Appliance malfunction!**

- ▶ If the problem persists, contact your installer.

### 6.4 Temperature selection



By default, the unit is set for 120 °F (49 °C) outlet water.

To select a hot water temperature:

- ▶ Press the buttons and until the desired temperature is displayed.

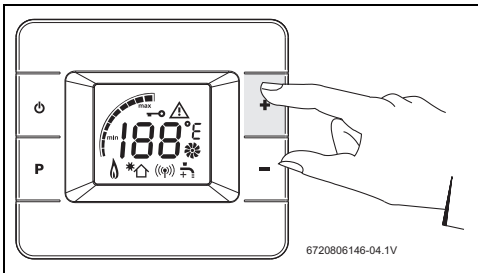

Fig. 29



To increase setpoint temperature limit of the appliance:

- ▶ Access the menu SL - temperature Limit (→ section 6.5.5).

A lower temperature set point will reduce the risk of scalding, reduce energy consumption and increase the longevity of the heat exchanger.



**WARNING:**

The temperature shown on the display is device measured, always check with your hand before bathing children or elderly.

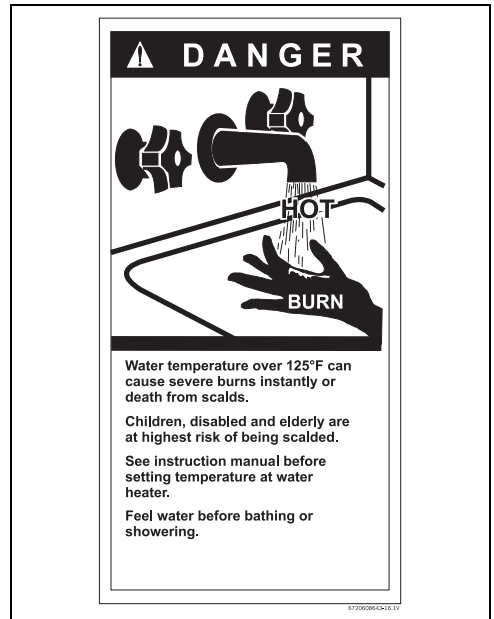

Fig. 30



### 6.4.1 Programming the default setpoint temperature

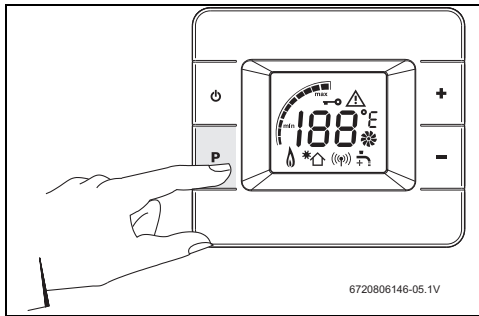

Fig. 31

- ▶ Press the buttons **+** and **-** to select the temperature to be memorized.
- ▶ Press the button **P** for 3 seconds to save the default set point temperature.

When the display stops blinking, the default set point temperature is saved in memory.

#### Selecting the default setpoint temperature

In order to select the default setpoint temperature.

- ▶ Press the programming button for 1 second.

Display shows the default setpoint temperature, which is now the hot water selected setpoint-temperature.

### 6.4.2 Solar Mode

If the appliance does not ignite, it means that the desired set temperature would be exceeded even running at minimum BTU. In this condition, the solar mode indicator will show on the display.

In most cases, solar mode is activated if the inlet water temperature exceeds the set point temperature minus 1 °F (0.5 °C).

#### Solar mode/warm inlet temperature activation formula

Temp. inlet > [Temp. set - 1 °F (0.5 °C)]

Ex.: 111 °F (43.9 °C) > [112 °F (44.4 °C) - 1 °F (0.5 °C)]

Table 15

### 6.5 Information /Adjustments menu

- ▶ Press simultaneously buttons **+**, **-** and **P** for 3 seconds. Display shows **P4 (Information)**.
- ▶ Press buttons **+** or **-** to scroll through the available menus.

### Available menus

Display	Description
P4	Information (section 6.5.1)
P7	Gas Type
P9	Purge (section 6.5.2)
PC	Cascading
SA	Settings (section 6.5.4)
LM	Temperature Limit (section 6.5.4)
PE	Appliance Type
PF	Bypass
PA	Actuator Calibration
IC	ICC
Pd	Power derate
E	Exit
P0	L2 Gas Adjust
P1	Maximum Power
P2	Low Power
UC	Automatic Calibration
P3	Powerbus Address

Table 16

To return to main menu,

- ▶ Press buttons **+** or **-** until display shows **E**.
- ▶ Press button **p** to exit. Display shows temperature setpoint.

### 6.5.1 P4 (Information)

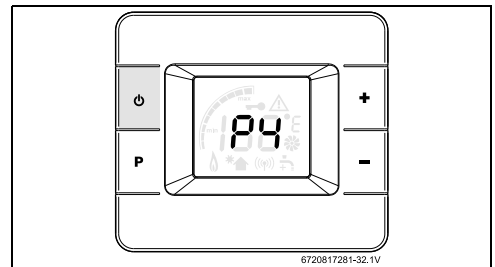

Fig. 32 P4 - Information

This menu provides access to several parameters.

- ▶ Access to information / adjustments manual. Display shows **P4 (Information)**.
- ▶ Press the button **P**. Display shows **E**.

## Operating Instructions

- ▶ Press buttons **+** or **-** to choose the following information.
  - **OD (Operation Data)**
  - **FH (Failure History)**
- ▶ Press the button **P** to select the desired information.

### OD (Operation Data)

Allows you to view various parameters of the current operation of the appliance.

- ▶ Press buttons **+** or **-** to choose the following information:
  - **0d (Chamber NTC)** - current water temperature at heat exchanger outlet.
  - **1d (Inlet NTC)** - current temperature of the temperature sensor of the water inlet pipe.
  - **2d (Outlet NTC)** - current temperature of the temperature sensor of the water outlet pipe.
  - **3d (Flow)** - total flow through main and bypass valves.
  - **4d (Barometric pressure)** - current barometric pressure at installation location.
  - **5d (Fan Speed)** - current fan speed.
  - **6d (Output Power)** - % current power.
  - **7d (SS Hex NTC)** - Flue gas temperature sensor at the condensing unit inlet (between heat exchangers).
  - **8d (Exhaust Gas NTC)** - Exhaust flue gas temperature sensor.
  - **9d (Ambient NTC)** - current temperature inside cabinet near the fan.
  - **10d (External Tank)** - current temperature on the external tank.
  - **11d (Operation Cycles)** - number of times burner has been started. The number of cycles should be read from 4C to 0C.
  - **12d (Operation Hours)** - number of minutes burner has been started. Time should be read from 4H to 0H.
  - **E** - Exit.

How to select desired information:

- ▶ Press the button **P** to view the selected parameter. The information is showed on the display.
- ▶ Press the button **P** to return to parameters list.
- ▶ Press buttons **+** or **-** to select **E**.
- ▶ Press the button **P** to exit.

### Numbers of cycles

To see how many cycles the appliance has done, please enter the menu **11d (Operation Cycles)**.

After checking the sub-modes **0C**, **1C**, **2C**, **3C**, **4C**, introduce the values in a table as the example below;

4C	3C	2C	1C	0C
00	04	06	17	76

Table 17 Total of cycles

In this example, the numbers of cycles is: 4061776.



In the calculation of number of cycles, **1 cycle means 1 ignition**.

### Numbers of hours

To see how many hours the appliance has worked, please enter the menu **12d (Operation Hours)**.

After checking the sub-modes **0H**, **1H**, **2H**, **3H**, **4H**, introduce the values in a table as the example below;

4H	3H	2H	1H	0H
00	00	00	18	63

Table 18 Total of hours

In this example, the numbers of hours is: 1863.

### FH (Failure History)

Allows you to view the last 10 error codes.

- ▶ Press buttons **+** or **-** to choose from **1F** (most recent failure) to **10F** (older failure).
- ▶ Press the button **P** to view the selected failure. The error code is shown on the display.
- ▶ Press the button **P** to return to failure list.
- ▶ Press buttons **+** or **-** to select **E**.
- ▶ Press the button **P** to exit.

### 6.5.2 P9 (Purge)

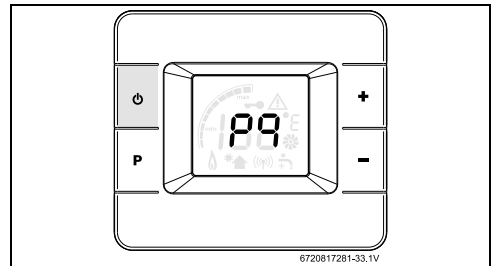

Fig. 33 P9 - Purge

This menu allows you to purge the exhaust circuit.

- ▶ Access to information / adjustments menu.  
Display shows **P4 (Information)**.
- ▶ Press the button **⏻** until the display shows **P9 (Purge)**.  
After 2 sec. the fan starts working to purge the exhaust circuit.



The fan remains running until the Purge menu is exited, to do so:

- ▶ Press the button **⏻**.

### 6.5.3 PC (Cascading)



Use this menu only after installing the cascading kit.

- ▶ Only a qualified technician can change this parameter.

How to choose an option in **PC** (Cascading),

- ▶ Press the button **P** to enter **PC** (Cascading).
- ▶ Press buttons **+** or **-** to scroll through the options.
  - **MA** (Primary)  
Appliance define as Primary
  - **SL** (Secondary)  
Appliance define as Secondary
  - **OF** (Off)  
Turn off the cascading function

How to select an option,

- ▶ Press buttons **+** or **-** to choose an option.
- ▶ Press the button **P** until selected option blinks.  
Option is activated.
- ▶ Press the button **P** to exit **PC** menu.

### 6.5.4 SA (Settings)

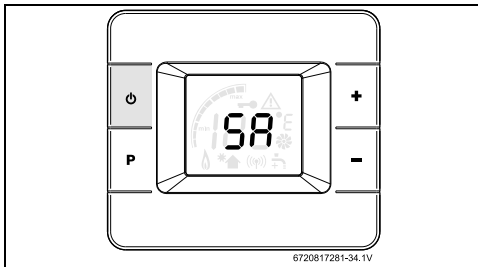

Fig. 34 SA - Settings

This menu provide access to several parameters.

- ▶ Access to information / adjustments menu.  
Display shows **P4 (Information)**.
- ▶ Press the button **⏻** until the display shows **SA (Settings)**.
- ▶ Press the button **P**.  
Display shows **E**.
- ▶ Press buttons **+** or **-** to choose the following information.
  - **E Exit**
  - **A0 Time**
  - **A1 Recirculation**
  - **A8 Startup Delay**
  - **A9 Units Set**
  - **Ab Region Selection**
  - **rS Recirculation Settings**
- ▶ Press the button **P** to select the desired information.

#### A0 Time

How to set the time:

- ▶ Press the button **P**.  
Menu Hours (12h or 24h) appears.
- ▶ Press buttons **+** or **-** to insert values.
- ▶ Long press on button **P** to set values.  
Value will blink and move to next menu.
- ▶ Repeat this procedure for all the menus,
  - **Hours (12h or 24h)**
  - **Minutes**
  - **AM or PM** (Only if 12h is selected)
  - **Week day (1- Monday, ..., 7- Sunday)**

To define/change a value;

- ▶ Use buttons **+** or **-** to change values.
- ▶ Long press on button **P** to set values.

To exit menus without setting values;

- ▶ Short press on button **P**.

#### A1 Recirculation

Choosing a recirculation program:

- ▶ Press the button **P**.

## Operating Instructions

- ▶ Press buttons **+** or **-** to scroll through the options.
  - **OF OFF**
  - **rE House Recirculation**
    - Hot water readily available at faucets.
  - **tI Tank Loading Internal NTC**
    - Tank loading using the water heater's inlet water temperature sensor to control the pump.
  - **tE Tank Loading External NTC**
    - Tank loading using the external temperature sensor to control the pump.
  - **tA Tank Loading Aquastat**
    - Tank loading using the external temperature sensor to control the pump.
- ▶ Press the button **P** to exit recirculation menu.

### Hr House Recirculation schedule programs



House recirculation function will only be functional after;

- ▶ Set the time in A0 menu.
- ▶ Connect a recirculation pump to the appliance.

The following schedules are available in the appliance. Every schedule has the program for the whole week.

Program	Schedule	Time ON	Time OFF	Time ON	Time OFF
S0	7 days/ week	6am	8am	4pm	8pm
S1	7 days/ week	6am	10am	5pm	10pm
S2	7 days/ week	5am	7am	3pm	7pm
S3	Mon - Fri	6am	8am	3pm	8pm
	Sat - Sun	7am	10am	5pm	11pm
S4	Mon - Fri	6am	10am	5pm	10pm
	Sat - Sun	7am	11am	5pm	11pm
S5	Mon - Fri	5am	7am	3pm	7pm
	Sat-Sun	6am	9am	5pm	9pm
S6	7days/ week	12am	2am	10am	12pm
S7	7days/ week	6am	8am	7pm	11pm
S8	7days/ week	6am	10pm	-	-
S9	7days/ week	Always on			

Table 19

To choose schedule programs;

- ▶ Press buttons **+** or **-** to scroll through the options.
  - **S0**
  - ...
  - **S9** (always active)
- ▶ Long press on button **P** to select the desired schedule. The desired schedule will blink for 3s.
- ▶ Press the button **P** to exit schedule menu.

### A8 (Startup Delay)

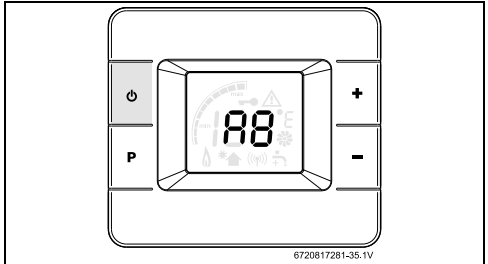

Fig. 35 A8- Startup Delay

This menu allows programming a burner start delay between 0 and 60 seconds, after detecting water flow.

- ▶ Access to information / adjustments menu. Display shows **SA (Settings)**.
- ▶ Use the buttons **+** or **-** to choose **A8 (Startup Delay)**.
- ▶ Press the button **P**. Display shows **Startup Value(s)**.
- ▶ Press the buttons **+** or **-** to define, in seconds, the delay to start-up after detection of the water flow.
- ▶ Press the button **P** for 3 seconds to save the desired value.
- ▶ Press the button **P** to exit **A8 (Startup Delay)** menu.

### A9 (Units Set)

This menu allows you to choose the units visible on the display.

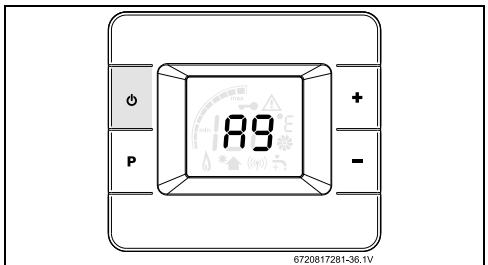

Fig. 36 A9 - Units

- ▶ Access to information / adjustments menu.  
Display shows **SA (Settings)**.
- ▶ Press the button **←** until **A9 (Units)** is in the display.
- ▶ Press the button **P**.
- ▶ Press the buttons **+** or **←** to select measurement units,
  - **°C - Metric (l/min)**
  - **°F - Imperial (gal/min)**
- ▶ Press the button **P** for 3 secs. to save the selected units.  
The selected unit blinks.
- ▶ Press the button **P** to exit units menu.

#### AB (Region Selection)

- ▶ Press the button **P**.  
Display shows following menu.
  - **EU (Europe)**
  - **nA (North America)**
- ▶ Press the button **P** for 3 secs. to save the select region.  
The selected region blinks.
- ▶ Press the button **P** to exit units menu.

#### RS Recirculation Settings

To define recirculation comfort level,

- ▶ Press the button **P**.
- ▶ Press buttons **+** or **←** to define comfort level.
  - **1**
  - **2**
  - ...
  - **9**

Choosing a higher comfort level (9) will set the recirculation water temperature closer to the set point defined on the water heater. Choosing a lower value (1) will favor efficiency at the expense of recirculation temperature comfort.

- ▶ Press the button **P** to select value and to exit Recirculation Settings.

#### 6.5.5 SL (Temperature Limit)



140 °F (60 °C) is the maximum temperature to be defined for residential models.

How to select Temperature Limit,

- ▶ Press the button **P**.  
Display shows temperature limit value.
- ▶ Press the buttons **+** or **←** to select desired temperature limit or **OF (OFF)** to unlock the Temperature Limit.
- ▶ Press the button **P** for 3 secs. to save your selection.  
The selected temperature blinks.

- ▶ Press the button **P** to exit Temperature Limit menu.

#### 6.5.6 PE (Appliance Type)



After defining these parameters, it isn't possible to modify.

This menu provide access to several parameters:

- ▶ Press the button **P**.
- ▶ Press buttons **+** or **←** to scroll through the options.
  - **TP (Appliance Type - Residential)**
  - **AP (Appliance Power - 199/160 kBTU)**
  - **nO (Appliance Model - IN/OU)<sup>1)</sup>**
  - **E (Exit)**
- ▶ Press the button **P** for 3 secs. to save your selection.
- ▶ Press the button **P** to exit recirculation menu.

#### 6.5.7 PF (Bypass Activation)



199 models the bypass setting is default ON.  
160 models the bypass setting is default OFF.

To Enable or Disable bypass function:

- ▶ Press the button **P**.
- ▶ Press buttons **+** or **←** to scroll through the options.
- ▶ Press the button **P**.  
Display shows following menu.
  - **EN (Enable)**
  - **DI (Disable)**
- ▶ Press the button **P** to select option.

#### 6.5.8 IC - Ionization control



Default setting is **On**.

- ▶ Only a qualified technician can change this parameter.

#### 6.5.9 Pd - Power derate



Default setting is **On**.

- ▶ Only a qualified technician can change this parameter.

1) IN - Indoor / OU - Outdoor

### 6.5.10 Minimum power and check (P2)



- ▶ Only a qualified technician can change this parameter.
- 

### 6.5.11 P1 - Max. Power (Ionization control)



Default setting is **Off**.

- ▶ Only a qualified technician can change this parameter.
- 

### 6.5.12 P0 - Min. Power (Ionization control)



Default setting is **Off**.

- ▶ Only a qualified technician can change this parameter.
- 

## 6.6 Water actuators calibration



Water valve calibration must be done when main water valve or bypass valve is replaced. Also required when electronic control unit is replaced.

---



The water valve calibration process takes several minutes.

- ▶ Do not interfere with the appliance.
- 

### 6.6.1 MF (Main Valve Auto Calibration)

- ▶ Open one hot water faucet.
- ▶ Access menu **PA**.
- ▶ Press the button **P**.
- ▶ Press the buttons **+** or **-** to select **MF**.
- ▶ Press the button **P**.  
The appliance will start the auto calibration of main valve.  
Display will show water flow rate value X 10 (multiplied by 10) during the process.



Water flow will shut-off.

- ▶ Wait until indication of calibration completed appears on the screen, the value blinks.
  - ▶ Wait until water flow blinks on the screen indicating that calibration is complete.
- 

- ▶ Press the button **P** to return.

### 6.6.2 BP (Bypass Valve Auto Calibration)

- ▶ Open one hot water faucet.  
Flow rate between 0.80 GPM and 1.80 GPM is required.  
It's possible to confirm this value by entering **BP Bypass Valve Auto Calibration** menu.
- ▶ Access menu **PA**.
- ▶ Press button **P**.
- ▶ Press button **+** or **-** to select **bp (bypass valve)**.
- ▶ Press button **P**.  
The appliance will start the auto calibration of the bypass valve.  
Display will show water flow rate value X 10 (multiplied by 10) during the process.



The display shows the flow rate.

- ▶ You should adjust the flow rate at the beginning of the calibration process.
  - ▶ Wait until water flow blinks on the screen indicating that calibration is complete.
- 

- ▶ Press the button **P** to return to main menu.

## 6.7 Gas type



Improper gas type will affect appliance performance.

---

- ▶ Press simultaneously buttons **+**, **-** and **P** for 3 seconds.  
Display shows **P4 (Information)**.
- ▶ Press buttons **+** or **-** to select **P7 (Gas Type)**.
- ▶ Press **P** to enter.
- ▶ Press buttons **+** or **-** to confirm gas type according to table 20.
- ▶ Press **P** for 3 seconds to confirm Gas type.  
The selected gas type blinks.

Gas type	Display
NG (natural gas)	NA
LP (Liquid Gas)	LP

Table 20

### 6.7.1 Gas conversion from NG to LPG

**! DANGER:**

**Fatal accidents!**

Before any service or testing in the appliance,

- ▶ Turn off the appliance.
- ▶ Disconnect the power supply cord.
- ▶ Shut off the gas supply.



The gas type conversion must only be carried out by a qualified contractor.

- ▶ Turn Off the appliance.
- ▶ Remove the front cover from the appliance (→ section 3.3.2).
- ▶ Remove the four screws that retain the cover plate to the gas manifold, see fig. 37 (plate in grey color).

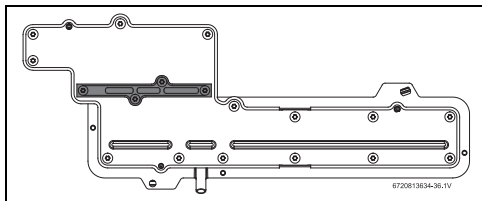

Fig. 37 Gas manifold

- ▶ Remove metal plate and seal.
- ▶ The 3 restrictor plates should be pre-assembled onto their tray, but if loose in box, follow installation instruction, as shown in fig. 38 [1].
- ▶ Insert the LP conversion plate in the appropriate location shown in Fig. 38 [2].

**! CAUTION:**

- ▶ All three flow restrictors and seal must be assembled according to the Fig. 38, to assure correct appliance performance.

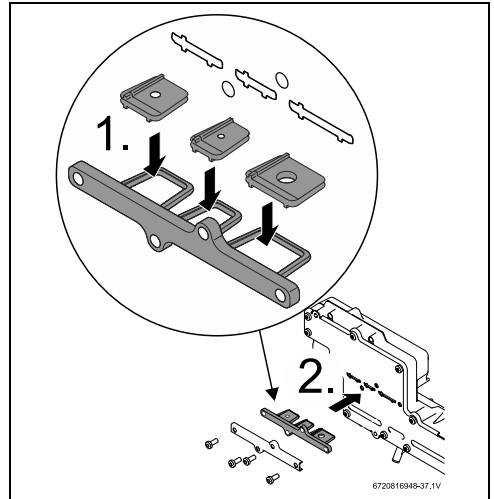

Fig. 38 199kBTU appliance gas conversion kit

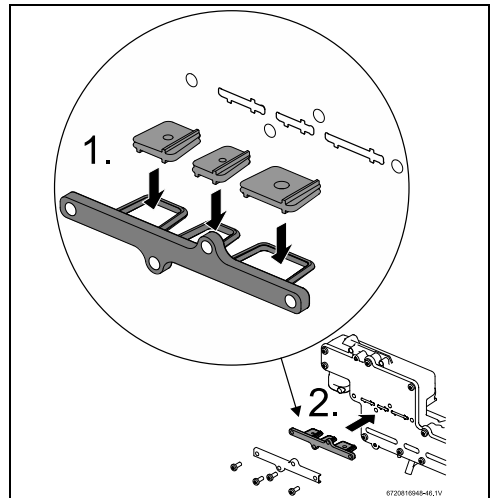

Fig. 39 160kBTU appliance gas conversion kit

- ▶ Tighten the four screws.
- ▶ Open the gas supply valve.
- ▶ Turn On the appliance.
- ▶ Check for gas leak (e.g. use leak detector fluid, like water and soap, over and around the metal plate) and act accordingly.



The flue gas restrictor must be assembled in the exhaust grill.

- ▶ Install the flue gas restrictor in the exhaust grill.

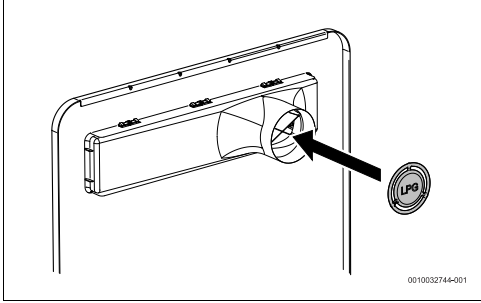

Fig. 40

- ▶ Assemble the front cover in the appliance.

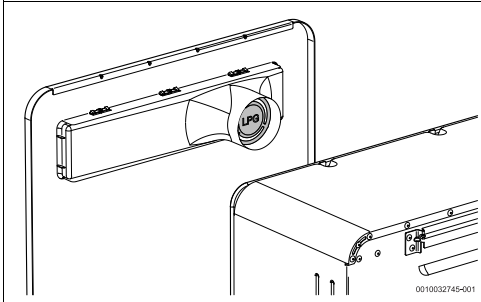

Fig. 41 Place the front cover

- ▶ Access service mode by pressing and hold down at the same time, **P**, **+** and **-** for 3 seconds.
- ▶ Press buttons **+** or **-** until the display shows "P7".
- ▶ Press **P**.
- ▶ Press buttons **+** or **-** to choose **LP** (LPG).
- ▶ Press the button **P** for 3 secs. to save your selection. The selected temperature blinks.
- ▶ Update "TYPE OF GAS" in the rating plate of the appliance using the label provided with the gas conversion kit.
- ▶ Confirm CO<sub>2</sub> and CO values and, if necessary, adjust the parameters P1 and P2, see chapter 8.11 for more information.

## 7 Maintenance and service



**WARNING:**

Maintenance must be done by a trained or qualified contractor.



**DANGER:**

- ▶ Always shut off the electrical power supply, shut off the manual gas valve and shut off the water valves whenever servicing.



**WARNING:**

- ▶ Replace all dismantled seals and o-rings with new ones.
- ▶ Consult spare part list at [www.bradfordwhite.com](http://www.bradfordwhite.com).

### NOTICE:

- ▶ Inspect and clean the complete water heating system once a year.
- ▶ Follow points 5 and 6 in Table 21 after 400 operation hours or 25000 cycles (whichever occurs first), see chapter 6.5.1 (Op. Data).
- ▶ Inspect the water heater and components for wear or fatigue. Immediately repair all faults to avoid damage to the system.

### Annual maintenance table

		Every year
1.	Inspect venting system	X
2.	Inspect combustion chamber	X
3.	Inspect burner	X <sup>1)</sup>
4.	Inspect pressure relief	X
5.	Inspect water filter	X
6.	Heat Exchanger Descaling	X <sup>2)</sup>
7.	Inspect condensate siphon	X
8.	Inspect air filter	X <sup>1)</sup>

- 1) Proceed with air filter cleaning or replacement if error code CE, CF and C2 is displayed. Check the flue exhaust for blockage (appliance is protected against flue blockage).



- 2) Proceed with heat exchanger descaling whenever error codes AA and E5 are displayed (appliance is protected against over heating in case of scaling, see table 1.1, Water Quality).

Table 21

## 7.1 Required annual maintenance

(To remove front cover, see page 13)

### Venting System

- Venting system - before removing the front cover inspect vent opening in the front cover for any blockage or restriction.
- Observe burner flames during heater operation (front cover must be removed). Burner flames should be steady and blue. Yellow, inconsistent (bouncing) flames may be an indication of poor ventilation or combustion air intake restriction. Inspect combustion air openings for blockage or debris.

### Combustion Chamber

- Inspect burner observation window for cracks or spillage of flue gases. Observe burner flames during heater operation. Flames should be steady and blue with no signs of yellowing. Yellow burner flames are an indication of improper combustion. Refer to Section 4.5.1 of this manual to verify the combustion air supply meets the manufacturer's specifications.

### Pressure Relief

- Manually open the pressure relief valve to ensure proper operation.

### Inlet Water Filter

- Verify the inlet water filter screen is clean and undamaged. The inlet water filter is located on the bottom of the appliance, to the right of the cold water inlet fitting. (See Fig. 13, page 22). Close the installer supplied water shutoff valve, purge the water using discharge drains and remove wireform spring clip from filter. Remove the filter, clean and/or replace if damaged.

### Descaling

- In areas where the water supply has a high mineral content (see table 1.1, Water Quality), the heat exchanger should be flushed with a descaling solution. Scale build up will shorten the life of the water heater, and damage resulting from scale is not covered under warranty. Refer to section 7.3 for detailed instructions on descaling the heat exchanger.

### Condensate Siphon

- Check for debris and clean if needed.

### Air Filter

- Verify the air filter is clean and undamaged. The air filter is attached to the fan assembly, see fig. 42.
- Air filter must be cleaned<sup>1)</sup> or replaced in case it is clogged or damaged.

### How to remove air filter

- ▶ Disconnect the electrical supply from the water heater.
- ▶ Remove appliance front cover, see page 13.
- ▶ Remove cover from the air filter.
- ▶ Loosen two philips head screws.
- ▶ Remove air filter from the fan.

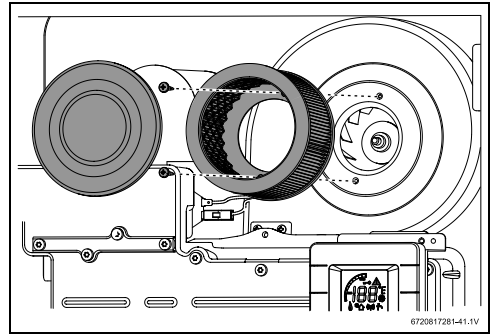

Fig. 42 Replace air filter

### NOTICE:

#### Appliance malfunction!

- ▶ Air filter should not be removed during appliance normal operation as, over time, it will lead to the burner blockage, requiring expensive repair.

## 7.2 Winterizing for seasonal use

The water heater must not be installed in a location where it may be exposed to freezing temperatures unless connected to electrical power. All water must be drained from the heater in order to avoid damage to the unit from exposure to freezing temperatures.

- 1) We do not recommend to wash the filter, gently shake it against a flat surface to remove the dust. A soft brush may also be used to aid cleaning.

### **NOTICE:**

Use of agents such as anti-freeze is not permitted and voids the warranty, as they may cause damage to the water heater's internal components.

---

1. Press ON/OFF switch on the water heater to turn OFF the heater and unplug power supply cord. The display should be blank.
  2. Shut off gas supply to heater.
  3. Shut off the water supply to the water heater using installer supplied shutoff valve.
  4. Open hot water faucets to drain and relieve pressure from the plumbing system. If water continues to flow after 5 minutes, a crossover of the hot and cold water pipes is present and must be corrected before proceeding.
  5. Disconnect the inlet and outlet water pipes from the water heater. Place a small bucket underneath the water heater to catch residual water remaining inside the water heater.
  6. Using an air compressor, blow short bursts of air (25psi max) through the inlet water connection until there is no water present coming through the outlet water connection of the heater.
  7. Empty condensate trap.
  8. Reconnect water fittings, refill the condensate trap and return heater to service when danger of freezing has passed.
- ▶ Using another line (B), connect the water outlet fitting on the water heater. Route the other end of this line into a descaling reservoir.
  - ▶ Using a 3rd line (C) from the descaling reservoir, connect to the inlet side of circulating pump. Install a filter on the end of the line in the descaling reservoir.
  - ▶ Make sure all connections are "water tight".
  - ▶ Fill bucket with descaling solution so both lines inside are submersed. We recommend a straight white vinegar solution. If using a commercial descalant, refer to manufacturer's instructions for proper dilution ratio.
  - ▶ Operate the circulating pump.
  - ▶ Make sure there are no leaks and the solution is flowing from the descaling reservoir through the heater and returning to the reservoir.
  - ▶ Run the solution through the heater until the solution returning to the descaling reservoir comes out clear. (Changing to a fresh solution may be necessary during this process).
  - ▶ Disconnect all lines and drain all solution from heat exchanger. Properly discard the solution.
  - ▶ Close the inlet drain connection.
  - ▶ Position a container below the hot water outlet and connect the cold water supply. Open the cold water supply shutoff valve and flush the heat exchanger with clean water.
  - ▶ Close the cold water shutoff valve and reconnect hot water supply to the water heater.
  - ▶ Close the outlet drain connection.

### **7.3 Mineral scale build-up**

Periodic descaling may be necessary in areas with high mineral content in the water, (see table 11, Water Quality). Scale buildup in the heat exchanger may result in lower flow rates, error codes of AA, E3, E5 and boiling sounds in the heat exchanger.

A water softener is required if the water hardness exceeds 12 grains/gal (200 mg/l) calcium carbonate. Damage to the water heater resulting from hard water/scale deposits will not be covered under warranty.

#### **Descaling using a pump**

- ▶ Disconnect the electrical supply from the water heater.
- ▶ Shut off the water supply to the water heater using (installer supplied) shutoff valve.
- ▶ Open hot water faucets to drain and relieve pressure from the plumbing system.
- ▶ Drain water from the unit's heat exchanger by disconnecting inlet and outlet water connections from the heater.
- ▶ Connect a line (A) from the outlet of the circulating pump (installer supplied) to the inlet water fitting on the water heater (see fig. 43).

- ▶ Reconnect the electrical supply to the unit, open the water shutoff valves, and return the unit to service.

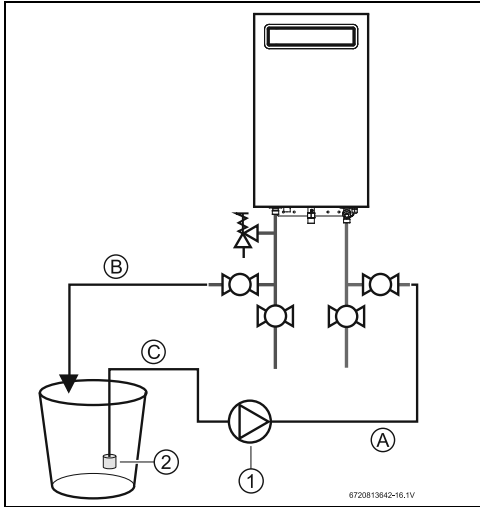

Fig. 43

- [1] Pump
- [2] Water filter

## 8 Troubleshooting



### WARNING:

If you are unable to perform the tasks listed below, or need additional assistance,

- ▶ Please contact your original installer or a licensed gas technician.

### NOTICE:

In some areas local code may require that the tasks described in this section must be performed by a certified contractor.

- ▶ Please check your local codes to ensure compliance.

### 8.1 Introduction

Many of the questions customers ask regarding operation of this unit can be answered by following the troubleshooting steps as outlined below. For best results, perform each step before proceeding to the next. The suggested solutions may require that the cover be taken off. (See fig. 3, page 13).

### 8.2 Burner does not ignite when a hot water faucet is opened

It is recommended to use “P4 Information” page 33, chapter 6.5.1 as a tool for problem solving.

1. If the display is blank, verify power at the outlet. (120VAC/60Hz properly grounded circuit required). Verify the heater power supply. Check all wire connections including plugged connectors.
2. With the water heater's power supply OFF and the power supply cord unplugged, remove the unit's front cover (See fig. 3, page 13). Check wire connections between the water valve, control unit and electrode set. See Fig. 52, page 56.
3. Verify the fuses in the control board are good. To access the fuses, the control board must be removed. See chapter 5.2, page 30.
4. Make sure cold water inlet connection is plumbed to the right side of the heater when facing unit. See fig. 12, page 22.
5. A minimum of 0.45 gallons per minute (1.7 l/m) of hot water demand is required to activate the heater. Confirm at least 0.4 gpm flow by timing how long it takes to fill a container. A quart container should fill in 20 seconds or less, from the hot water faucet only. Gradually increase water flow (hot water demand) through the heater to determine if the heater activates with higher flow.
6. Clean the inlet water filter screen per chapter 4.10, page 22.
7. Inspect the water path for obstructions. Make sure all shower heads, faucet aerators and whole house filters are clear of debris.
8. Check for a plumbing crossover. A crossover in the hot and cold plumbing pipes creates back pressure on the water flowing through the heater. Therefore, a higher flow rate than normal is needed to force the heater to activate. To check for a plumbing crossover, shut off the cold water supply to the water heater. Then open all of the hot water faucets served by the water heater. Wait 10 minutes and check for water flow at each faucet. There should be no water flowing. Any continuous flow of water, small or large, indicates a crossover is present and must be corrected. Consult a professional plumber for help in correcting a crossover. Failing single lever faucet mixing valves are common causes of plumbing crossovers.

### 8.3 Water is too hot

1. Selected temperature on the unit may be too high. To lower output temperature, see chapter 6.4, page 32.
2. Confirm the heater's gas type coincides with the type of gas being supplied. See fig. 2, page 13 for the location of the rating plate.

3. In areas where the water has a high mineral content, periodic descaling may be necessary. See chapter 7.3, page 42 for directions.

### 8.4 Water is not hot enough

1. Selected temperature on the unit may be too low. To raise the output temperature, see chapter 6.4, page 32.
2. Confirm the heater's gas type coincides with the type of gas being supplied. See fig. 2, page 13 for the location of the rating plate.
3. Check the inlet gas particle screen for blockage at inlet of the gas connection on bottom of unit.
4. Verify the gas pressure is in accordance with specifications in chapter 4.17, page 29. A gas pressure reading is needed to proceed further. Contact your original installer or a local certified gas technician to obtain this reading.
5. Cold water may be mixing into the hot water lines (plumbing crossover). A plumbing crossover can unintentionally mix cold water with the hot water leaving the heater. The end result is a cooler water temperature than desired. To check for a plumbing crossover, shut off the cold water supply to the water heater. Then open all of the hot water faucets served by the heater. Wait 10 minutes and check all faucets for water flow. There should be no water flowing. Any continuous flow of water, small or large, indicates a crossover and must be corrected. Consult a professional plumber for help in correcting a crossover. Failing single lever faucet mixing valves are common causes of plumbing crossovers.

### 8.5 Low water flow/pressure

1. Too many hot water applications are being used simultaneously or too much flow is demanded. The water heater will effectively support two 2.0-2.5 GPM shower heads simultaneously or multiple sink applications. Greater draws will result in a water pressure drop and reduced flow at faucets.
2. If the selected temperature on the unit is set too high for the demanded flow rate, the water heater will close its motorized water valve, reducing the hot water flow rate in an attempt to reach the selected output temperature. Lowering the selected temperature will allow the motorized water valve to open up for increased water flow rate.
3. Clean the inlet water filter screen per chapter 7.1, page 41 to increase flow through the heater.
4. Inspect the water path for obstructions. Make sure all shower heads, faucet aerators and whole house filters are clear of debris. It may be necessary to upgrade to higher flow rate shower heads if allowed by local code.

5. In areas where the water has a high mineral content, periodic descaling may be necessary. See chapter 7.3, page 42 for directions.

### 8.6 Hot water temperature fluctuates at faucet

1. If the water heater set point temperature is high, mixing at the faucet could deactivate the water heater. The addition of too much cold will overpower hot water flow from the tankless water heater reducing its flow below the activation point.  
If this slows the flow through the tankless water heater below its activation point, it will shut off the burners. The end result is nothing but cold water coming out of the outlet. Consult [www.bradfordwhite.com](http://www.bradfordwhite.com) for a detailed service bulletin on overcoming temperature fluctuations.
2. Unbalanced pressure in water lines. Any restriction in the water heater, such as a clogged inlet water filter screen, can result in unequal pressures between the cold and hot water lines. In such cases, when mixing in the higher pressure cold water at the faucet, the lower pressure hot water can be overpowered. This will shut down the burners because the hot water flow rate fell below the minimum flow rate required for activation. Verify that the inlet water filter screen is clean and clear of debris. See chapter 7.1, page 41 for inlet water filter cleaning instructions.
3. The water heater may be deactivated by temperature balancing valves. If the water heater's set point temperature is set too high, the heater can produce temperatures that are too hot. A temperature balance shower valve will automatically mix in cold water to reduce the hot water temperature. In the event of any temperature instability at a fixture using a temperature balancing valve, refer to the valve manufacturer for instructions on internal adjustment setting. An adjustment should be made to minimize the amount of cold water the valve is adding. Additionally, the temperature setting on the water heater can be lowered to reduce the amount of cold water that the temperature balance valve mixes in.
4. Inlet water pressure is erratic due to fluctuating supply water pressure. For installation on a private well system with the use of a pressure tank, the lowest pressure range setting recommended is 30 - 45 psi (2.06 - 3.1 bar). Consult your installer or local plumber for effective ways to maintain constant water pressure to the appliance when on a well system.

### 8.7 Noisy burner/heater during operation

Burner noises can be heard if combustion is not properly set. This could be caused by improper gas supply conditions (gas pressure and/or gas composition).  
Two types of noise can be heard: low pitch noise/vibration (rumbling) and high pitch noise/vibration (whistling).

### 8.7.1 High pitch noise

1. Verify if correct gas type is selected (see section 6.7).
2. Verify if gas pressure is within specified range (see section 3.2).  
If gas type is properly selected, gas pressure is within range and the problem persists:
3. Perform the gas and air adjustment as described in section 8.1.1.

### 8.7.2 Low pitch noise

1. Verify if correct gas type is selected (see section 6.7).
2. Verify if gas pressure is within specified range (see section 3.2).  
If gas type is properly selected, gas pressure is within range and the problem persists:
3. Perform the gas and air adjustment as described in section 8.1.1.

### 8.8 Error codes C1, C2, CF and/or CE

C1, C2, CF and CE errors could be caused by an obstruction in the venting.

1. Verify if there are any venting obstructions and remove them if that is the case.
2. Clean or replace the air filter, see chapter 7.1, page 41.
3. Reset the error by holding the On/Off button for 3s.  
If there are no obstructions, and the problem persists:
4. Perform the gas and air adjustment as described in section 8.1.1.
5. If it is not possible to solve the problem with these measures and error persists, the burner surface (ceramat) might be obstructed (e.g. clogging due to dust/particles in the air). Contact Bradfordwhite support line for further assistance into the diagnosis if your installation fits this description; in case of confirmation, replace the burner and revise installation conditions (→ section 4.3) to avoid reoccurrence.

### 8.9 Error codes EA and/or EC

EA and EC errors can appear if combustion is not properly set. This could be caused by improper gas supply conditions (gas pressure and/or gas composition).

1. Verify if correct gas type is selected (see section 6.7).
2. Verify if gas pressure is within specified range (see section 3.2).  
If gas type is properly selected, gas pressure is within range and the problem persists:
3. Perform the gas and air adjustment as described in section 8.1.1.

### 8.10 Manifold gas pressure



**DANGER:**

#### Fatal accidents!

When the appliance is operating with the front cover removed:

- ▶ Do not stand in front of the appliance.
- ▶ Avoid breathing the combustion flue gases.
- ▶ Turn off the appliance and install the front cover assembly when adjustments and measurement are complete.

The manifold gas pressure measurement is only carried out if it is necessary to confirm the value from the rating plate. In case of a high deviation between measured and stated values, please proceed with Gas/air adjustment (see section 8.11) <sup>1)</sup>.

- ▶ Turn Off the appliance.
- ▶ Remove the front of the appliance (see page 13).

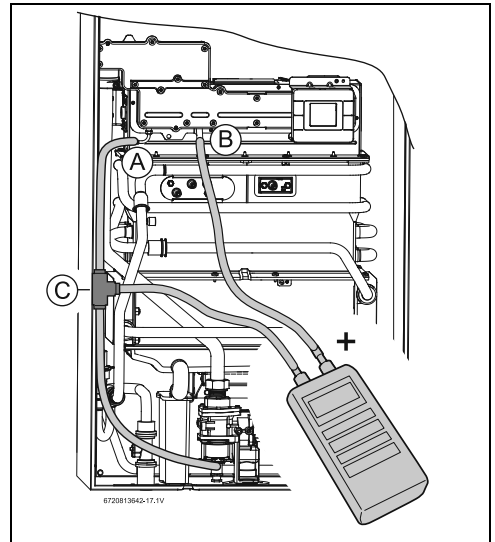

Fig. 44 Pressure head points

- [A] Air pressure head in the box
- [B] Gas pressure head in the burner
- [C] Tee (installer supplied)

- ▶ Loosen the shutter screw of the pressure head point [B].

- 1) Manifold gas pressure from the rating plate is valid for sea level operation with standard gas pressure and composition. If operating conditions are different from those, values from section 8.11 should prevail over manifold gas pressure to assure a correct appliance tuning.

## Troubleshooting

- ▶ Connect the pressure gauge connection "+" to the test point [B].
- ▶ Loosen the shutter screw of the pressure head point [A].
- ▶ Connect the pressure gauge "-" to the pressure head point [A].
- ▶ Turn On the appliance.
- ▶ Open all hot water faucets to achieve a flow rate of at least 6 gallons per minute. (1 tub and 2 sinks should be sufficient). If heater goes back to P2, open more hot water fixtures to allow sufficient flow and access to **P1 menu**.
- ▶ Record the manifold gas pressure reading in table 22. Manifold gas pressure refers to the relative pressure between gas manifold nozzles inlet and outlet [A]-[B].

	Value	Date
<b>Manifold gas pressure</b>		

Table 22

- ▶ Turn Off the appliance.
- ▶ Disconnect the pressure gauges from the pressure heads points [A] and [B].
- ▶ Tighten the shutter screws of the pressure heads points [A] and [B].
- ▶ Place front cover in the appliance.
- ▶ Turn ON the appliance to return to normal operation.

## 8.11 Adjusting Gas/Air flow



### **DANGER:**

#### **Risk of CO poisoning!**

Gas air/flow adjustment is performed with the front cover of the appliance removed. Avoid exposure to exhaust vent gases. Do not stand in front of the exhaust vent while appliance is operating.



**Appliance is pre-adjusted by default with factory parameters.**

#### **Gas/Air adjustments are only required when;**

- The appliance is converted to LPG and energy content is more than 2820 BTU/cu ft (→ chapter 6.7).
- After installation, the appliance shows repeated unresolved errors (→ chapter 9).
- After replacement of electronic control unit, fan or gas valve.



**Improper gas pressure** will affect combustion.

- ▶ Please see chapter 4.17 for more information.

### **8.11.1 Automatic adjust of Gas/Air flow**

- ▶ Press and hold simultaneously buttons **P**, **+** and **-** for 3 seconds.
- ▶ Press the buttons **+** or **-** to select **UC (Combustion Automatic Adjustment)** menu.
- ▶ Press the button **P** to enter **UC** menu. Automatic adjustment will begin.
- ▶ Open hot water faucets when the display shows **Tap Symbol** image (1 tub and 2 sinks should be sufficient; when there is enough water flow the image disappears).

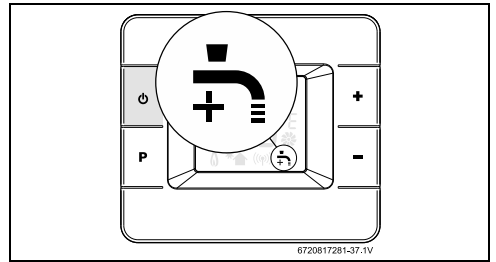

Fig. 45 Combustion Auto Adjust - Open Taps



The Combustion Auto Adjust process takes several minutes. Steps from 1 to 7 will appear on the display.

- ▶ Do not interfere with the appliance during the auto adjustment process.



If the display shows "**AD**" during calibration process,

- ▶ Press **P** button which will resume the calibration process.

- ▶ Wait until display shows **DN** blinking as a sign of calibration complete.

- ▶ Touch the symbol **P** to exit **UC** menu.

**Gas and Air auto adjustment is complete.**



In case of failure in the auto calibration process the error sign appears.

Verify if:

- ▶ Any error codes appear on the display. See table 25.
  - ▶ Gas type and pressure are correct.
  - ▶ Wind conditions are stable (e.g. wind gusts may be a cause of failure).
  - ▶ Hot water flow is sufficient and stable (e.g. water from a well is a potential source of water instability).
- In case of positive results for all these actions:

- ▶ Exit UC menu and repeat the process.
- ▶ Perform manual adjustment according to chapter 8.11.2 or contact your original installer or a local certified gas technician for further assistance.

### 8.11.2 Manual adjust Gas/Air flow

Gas/Air flow adjustment is also possible to perform manually (only recommended if automatic adjustment can not conclude successfully).

#### First step - Adjust the maximum power (P1)

- ▶ Press the button to turn ON.
- ▶ Press and hold simultaneously buttons , and for 3 seconds, until display reads **P4**.

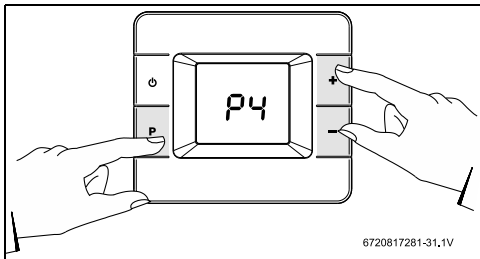

Fig. 46

- ▶ Press the buttons or to select **P1 (Maximum Power)** menu.
- ▶ Open hot water faucets when the display shows **Tap Symbol** image (1 tub and 2 sinks should be sufficient; when there is enough water flow the image disappears).
- ▶ Press **P** to enter **P1** adjustment. Display shows **E**.
- ▶ Press or until **L1** appears.
- ▶ Press the button **P** to enter **L1**. Display shows **L1** value.

- ▶ Verify if power bar level is at middle point, see fig. 47.

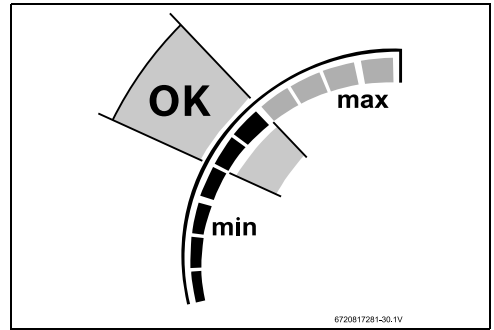

Fig. 47 Power bar middle point

- ▶ Press the buttons or to adjust parameter value if power bar level is out of range.<sup>1)</sup>

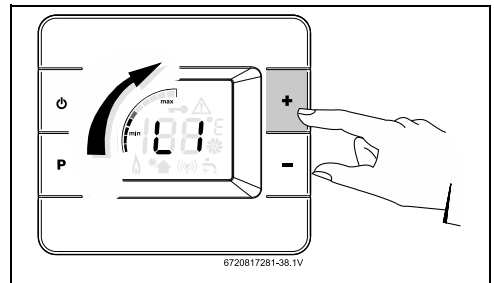

Fig. 48 Gas adjust - L1 parameter

- ▶ Press the button **P** for 3 seconds and appliance assumes value.
- ▶ Press the button **P** to save the value. Display will be back to **P1** menu.
- ▶ Press the button **P** to enter L1 and verify if power bar level is at middle point, see fig. 48.
- ▶ Repeat the process until **L1** gas adjust is correct.
- ▶ Press **P** button to finish the L1 gas adjust.
- ▶ Press the button or until the display shows **"A1"**.
- ▶ Press the button **P** to enter A1. Display shows A1 value.
- ▶ Verify if power by level is at middle point, see fig. 47.

1) Increasing L1 value will cause an increase in power bar level and vice-versa.

## Troubleshooting

- ▶ Press the buttons **+** or **-** to adjust parameter value if power bar level is out of range.<sup>1)</sup>

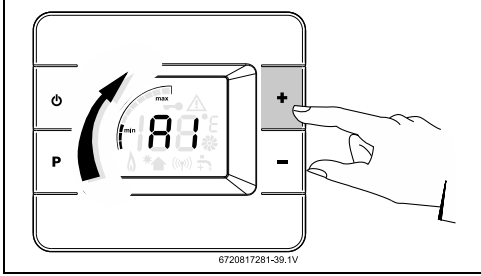

Fig. 49 Air adjust - A1 parameter

- ▶ Press the button **P** for 3 seconds and appliance assumes value.  
The value flashes as a sign of confirmation.
- ▶ Press the button **P** to finish the A1 air adjust.
- ▶ Press the button **+** or **-** until the display shows "b1".



If **b1** is blinking on the display,

- ▶ Wait until it stops.

- ▶ Press the button **P** to enter b1.
- ▶ Open water faucet if display shows water faucet symbol, see fig. 27, [4].  
Display shows the parameter value blinking during calibration.
- ▶ Wait until display shows **b1** blinking as a sign of calibration complete.
- ▶ Press **P** button to finish the b1 automatic air adjust.
- ▶ Press the button **+** or **-** until the display shows **E**.
- ▶ Press the button **P**.  
Display shows **P1**.

### Second step - Adjust the minimum power (P2)



Keep hot water faucets opened to adjust **minimum power (P2)**. The unit will ramp down to low fire and the water flow should decrease automatically.

- ▶ Press the buttons **+** or **-** to select **P2 (Minimum Power)** menu.

1) Increasing A1 or L2 value will cause a decrease in power bar level and vice-versa.

- ▶ Press **P** to enter **P2** adjustment.  
Display shows **E**.
- ▶ Press **+** or **-** until **L2** appears.
- ▶ Press the button **P** to enter **L2**.  
Display shows **L2** value.
- ▶ Verify if power bar level is at middle point, see fig. 47.
- ▶ Press the buttons **+** or **-** to adjust parameter value if power bar level is out of range.<sup>1)</sup>
- ▶ Press the button **P** for 3 seconds and appliance assumes value.  
The value flashes as a sign of confirmation.
- ▶ Press **P** button to finish the L2 gas adjust (U1).

### Parameter D2



- ▶ Only a qualified technician can change this parameter.

### Gas and Air adjustment is complete.

#### 8.11.3 Factory default settings

##### Restore factory values for P1 Max. Power



To restore factory values for combustion settings.

- ▶ Proceed with the following steps.
- ▶ Access to menu **P1 Max. Power**.
- ▶ Press symbols **+** or **-** to select **rP** reset parameters.
- ▶ Press the symbol **P** to select **rE**.
- ▶ Press **P** for 3 seconds.
- ▶ Press the symbol **P**.  
The display blinks to confirm change.
- ▶ Press the symbol **P**.  
The factory default values for **P1** are restored.

##### Restore factory values for P2 MIN. Power

- ▶ Access to menu **P2 Min. Power**.
- ▶ Press symbols **+** or **-** to select **rP** reset parameters.
- ▶ Press the symbol **P** to select **rE**.
- ▶ Press **P** for 3 seconds.
- ▶ Press the symbol **P**.  
The display blinks to confirm change.
- ▶ Press the symbol **P**.  
The factory default values for **P2** are restored.



## 8.12 CO emissions check

In case air/gas combustion adjustment has been performed check emissions using reference values in tables 23 and 24.

### 8.12.1 Access to CO<sub>2</sub> measuring port



**WARNING:**

**Only a qualified technician can perform these steps.**

This can cause carbon monoxide poisoning.

- ▶ Follow the instructions carefully.



**Allow the appliance to stabilize before performing CO readings.**

**Let appliance warm up and wait for 5 minutes for each CO reading.**

**This will avoid wrong CO readings.**

- ▶ Open a hot water faucet and let the appliance work for 2 or 5 minutes.
- ▶ Remove the protection from the front cover, see fig. 50.

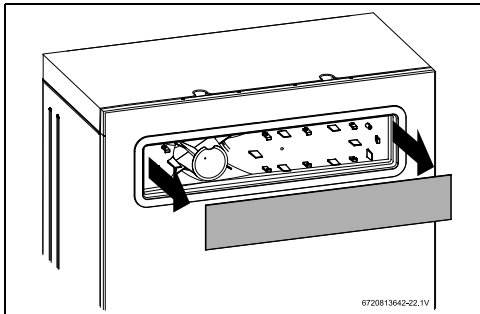

Fig. 50 Remove protection

- ▶ Remove the front cover from the appliance.
- ▶ Enter in P1 and P2 menus to make the readings.
- ▶ Place the front cover during the readings.

- ▶ Insert analyzer probe into the measuring port (approx. 1.5" inserted), see fig. 51.

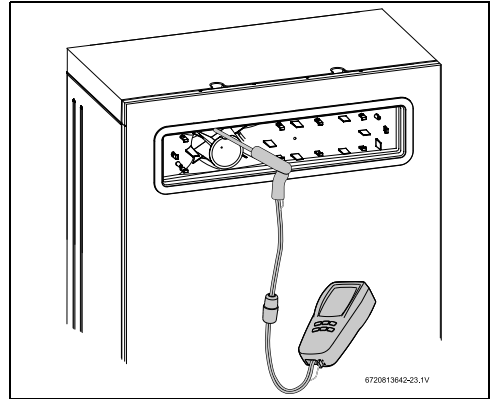

Fig. 51 Measuring port

8.12.2 CO<sub>2</sub> and CO values

		CO <sub>2</sub> range (%)	Max. CO level (measured)
		Greentherm 9800 SE/SEC O 199 000 BTU	
		<b>Nat. Gas</b>	
<b>max. input</b>	P1	8.4 % - 9.0 %	< 250 ppm
<b>min. input</b>	P2	N/A	< 100 ppm
		<b>LP Gas</b>	
<b>max. input</b>	P1	9.7 % - 10.4 %	< 250 ppm
<b>min. input</b>	P2	N/A	< 100 ppm
<p><b>* Values above are for climate controlled conditions. Inputs such as gas pressure, heating value of the gas, humidity and temperature of combustion air all impact CO and CO<sub>2</sub> values. Changes in these inputs can result in different CO and CO<sub>2</sub> values on the same appliance.</b></p>			

Table 23 CO & CO target numbers

		CO <sub>2</sub> range (%)	Max. CO level (measured)
		Greentherm 9800 SE O 160 000 BTU	
		<b>Nat. Gas</b>	
<b>max. input</b>	P1	8.5 % - 9.1 %	< 250 ppm
<b>min. input</b>	P2	N/A	< 100 ppm
		<b>LP Gas</b>	
<b>max. input</b>	P1	10.0 % - 10.6 %	< 250 ppm
<b>min. input</b>	P2	N/A	< 100 ppm
<p><b>* Values above are for climate controlled conditions. Inputs such as gas pressure, heating value of the gas, humidity and temperature of combustion air all impact CO and CO<sub>2</sub> values. Changes in these inputs can result in different CO and CO<sub>2</sub> values on the same appliance.</b></p>			

Table 24 CO & CO target numbers

8.12.3 Returning to Service

- ▶ Remove the analyzer probe and place the protection on the front cover.
- ▶ Remove the front cover to access HMI.
- ▶ Press the button **+** or **-** until the display shows **E**.
- ▶ Press the button **P** to return main menu.  
Display shows selected setpoint temperature.
- ▶ Place the front cover.

## 9 Problem solving

### 9.1 Error code diagnostics



To remove error codes from the display,

- ▶ Press the ON/OFF button more than 3 sec. (long press).

Installation, maintenance and repair must only be carried out by qualified contractors. The following table describes the solutions for possible problems.

Display	Description	Solution
A0	Water temperature sensors [17] [19] [20] disconnected or damaged.	<ul style="list-style-type: none"> <li>▶ Check sensor wire connections.<sup>1) 2)</sup></li> <li>▶ Replace the sensor and/or wire connections, if the problem persists.<sup>1)</sup></li> </ul>
A1	Air temperature inside the cabinet [18] is above 158 °F (70 °C). Appliance regulates power to protect against overheat.	<ul style="list-style-type: none"> <li>▶ External air temperature is above 140 °F (60 °C).</li> <li>▶ Check for flue leakages inside the appliance.<sup>1)</sup></li> </ul>
A2	External water temperature sensor/aquastat [21] disconnected, damaged or not properly installed.	<ul style="list-style-type: none"> <li>▶ Check temperature sensor and associated connections.<sup>1) 2)</sup></li> <li>▶ Check sensor position in the tank pocket.</li> <li>▶ Verify if correct recirculation settings are in use (→section 4.12).</li> <li>▶ Replace the sensor and/or wire connections, if the problem persists.<sup>1)</sup></li> </ul>
A3	Flue gases temperature sensor [15] disconnected or damaged.	<ul style="list-style-type: none"> <li>▶ Check sensor wire connections.<sup>1) 2)</sup></li> <li>▶ Replace the sensor and/or wire connections, if the problem persists.<sup>1)</sup></li> </ul>
A4	Air temperature sensor [18] disconnected or damaged.	<ul style="list-style-type: none"> <li>▶ Check sensor wire connections.<sup>1) 2)</sup></li> <li>▶ Replace the sensor and/or wire connections, if the problem persists.<sup>1)</sup></li> </ul>
A5	Condensing unit flue temperature sensor [16] disconnected or damaged.	<ul style="list-style-type: none"> <li>▶ Check sensor wire connections.<sup>1) 2)</sup></li> <li>▶ Replace the sensor and/or wire connections, if the problem persists.<sup>1)</sup></li> </ul>
A6	Inlet cold water temperature sensor [20] disconnected or damaged.	<ul style="list-style-type: none"> <li>▶ Check sensor wire connections.<sup>1) 2)</sup></li> <li>▶ Replace the sensor and/or wire connections, if the problem persists.<sup>1)</sup></li> </ul>
A7	Heat exchanger hot water temperature sensor [16] disconnected or damaged.	<ul style="list-style-type: none"> <li>▶ Check sensor wire connections.<sup>1) 2)</sup></li> <li>▶ Replace the sensor and/or wire connections, if the problem persists.<sup>1)</sup></li> </ul>
A8	Outlet hot water temperature sensor [17] disconnected or damaged.	<ul style="list-style-type: none"> <li>▶ Check connections or replace sensor.<sup>1) 2)</sup></li> <li>▶ Replace the sensor and/or wire connections, if the problem persists.<sup>1)</sup></li> </ul>
A9 <sup>3)</sup>	Incorrect output power (too low).	<ul style="list-style-type: none"> <li>▶ Check gas inlet pressure<sup>1)</sup> (→ section 4.17).</li> <li>▶ Check water temperature sensors [17][19][20] and water flow sensor [14] wire connections.</li> <li>▶ Check connections or replace sensor (→section 11), replace any if it is not according to specification.<sup>1) 2)</sup></li> </ul>





## Problem solving

Display	Description	Solution
AA <sup>3)</sup>	Condensing unit flue gases temperature [16] above 392 °F (200 °C) and/or flue gases temperature [15] above 145 °F (63 °C) at the exhaust sensor [15]. Appliance regulates power to protect against overheating.	<ul style="list-style-type: none"> <li>▶ Check flue gas temperature sensor.</li> <li>▶ Check water inlet temperature sensor.</li> <li>▶ Descale appliance (→ section 7.3). <sup>1)</sup></li> </ul>
AD	Appliance power derate and possible reduce of comfort level. For installation above 2000 ft dependent on altitude and flue length, the appliance will have derate, water heater will continue operating, and the warning can not be removed.	<ul style="list-style-type: none"> <li>▶ Reset error (press and hold on/off button for 3 seconds).</li> <li>If the problem persists: <ul style="list-style-type: none"> <li>▶ Check air openings and exhaust opening for obstructions and reset the error.</li> <li>▶ Check if the air filter is dirty or clogged, replace it if needed. If air filter is not installed burner may be clogged and need to be replaced.</li> <li>▶ Perform gas and air tuning (→ section 8.11). <sup>1)</sup></li> </ul> </li> </ul>
BB	Fan calibration triggered due to missed ignitions.	<ul style="list-style-type: none"> <li>▶ Check gas inlet pressure (→ section 4.17). <sup>1)</sup></li> <li>▶ Perform gas and air tuning (→ section 8.11). <sup>1)</sup></li> </ul>
BC	Successive fan calibration with similar learned values.	<ul style="list-style-type: none"> <li>▶ Check gas inlet pressure (→ section 4.17). <sup>1)</sup></li> <li>▶ Perform gas and air tuning (→ section 8.11). <sup>1)</sup></li> </ul>
C1 <sup>4)</sup> C2 <sup>3)</sup>	Excessive flue blockage detected during startup due to insufficient combustion air. Appliance shuts down for safety.	<ul style="list-style-type: none"> <li>▶ Reset error (press and hold on/off button for 3 seconds).</li> <li>If the problem persists: <ul style="list-style-type: none"> <li>▶ Check air openings and exhaust opening for obstructions and reset the error.</li> <li>▶ Check if the air filter is dirty or clogged, replace it if needed.</li> <li>▶ Perform gas and air tuning (→ section 8.11). <sup>1)</sup></li> <li>▶ Contact Bradford White support line for additional information and assistance in case of installation in dusty areas.</li> </ul> </li> </ul>
C3	Flow sensor [14] does not detect water recirculation.	<ul style="list-style-type: none"> <li>▶ Check pump and connections. <sup>1)</sup></li> <li>▶ Check recirculation circuit for any blockage.</li> </ul>
C5	Bypass water valve [8] disconnected or damaged.	<ul style="list-style-type: none"> <li>▶ Check bypass water valve wire connections. <sup>1)</sup></li> <li>If the problem persists: <ul style="list-style-type: none"> <li>▶ Check if bypass water valve is clogged, the appliance will continue to operate without the bypass.</li> <li>▶ Replace the bypass water valve and/or wire connections. <sup>1)</sup></li> </ul> </li> </ul>
C7	Fan [2] disconnected or damaged.	<ul style="list-style-type: none"> <li>▶ Check fan wire connections.</li> <li>▶ Reset error (press and hold on/off button for 3 seconds).</li> <li>If the problem persists: <ul style="list-style-type: none"> <li>▶ Replace the fan and/or wire connections. <sup>1)</sup></li> </ul> </li> </ul>
C8	Main water valve [22] disconnected or damaged.	<ul style="list-style-type: none"> <li>▶ Check main water valve wire connections. <sup>1)</sup></li> <li>If the problem persists: <ul style="list-style-type: none"> <li>▶ Replace main water valve and/or wire connections. <sup>1)</sup></li> </ul> </li> </ul>

Display	Description	Solution
C9	Barometric pressure sensor damaged.	<ul style="list-style-type: none"> <li>▶ Reset error (press and hold on/off button for 3 seconds).</li> <li>If the problem persists:</li> <li>▶ Replace electronic control unit (ECU). <sup>1)</sup></li> </ul>
CA	Water flow above 9.2gpm.	<ul style="list-style-type: none"> <li>▶ Disconnect the appliance and purge hydraulic circuit to remove air. <sup>1)</sup></li> <li>▶ Install water flow restrictor. <sup>1)</sup></li> <li>▶ Check water pressure does not exceed 150psi. (→section 3.2).</li> </ul>
CE	Excessive flue blockage detected during operation due to excessive pressure on the siphon. Appliance shuts down for safety.	<ul style="list-style-type: none"> <li>▶ Reset error (press and hold on/off button for 3 seconds).</li> <li>If the problem persists:</li> <li>▶ Check air openings and exhaust opening for obstructions and reset the error.</li> <li>▶ Check if the air filter is dirty or clogged.</li> <li>▶ Perform gas and air tuning (→ section 8.11). <sup>1)</sup></li> <li>▶ Contact Bradford White support line for additional information and assistance in case of installation in dusty areas.</li> </ul>
CF	Excessive flue blockage detected during operation due to insufficient combustion air. Appliance shuts down for safety.	<ul style="list-style-type: none"> <li>▶ Reset error (press and hold on/off button for 3 seconds).</li> <li>If the problem persists:</li> <li>▶ Check air openings and exhaust opening for obstructions and reset the error.</li> <li>▶ Check if the air filter is dirty or clogged replace it if needed.</li> <li>▶ Perform gas and air tuning (→ section 8.11). <sup>1)</sup></li> <li>▶ Contact Bradford White support line for additional information and assistance in case of installation in dusty areas.</li> </ul>
E0	Electronic control unit internal error.	<ul style="list-style-type: none"> <li>▶ Reset error (press and hold on/off button for 3 seconds).</li> <li>If the problem persists:</li> <li>▶ Replace electronic control unit. <sup>1)</sup></li> </ul>
E1	Hot water temperature above 194 °F (90 °C). Appliance burner cut off to prevent scalding and reactivation after cooling down.	<ul style="list-style-type: none"> <li>▶ Disconnect the appliance and purge hydraulic circuit to remove air.</li> <li>If the problem persists:</li> <li>▶ Reduce setpoint temperature to minimize temperature instabilities.</li> </ul>
E3	Flue temperature above 167 °F (75 °C) or 2 minutes above 145 °F (63 °C). Appliance burner cut off to prevent overheating.	<ul style="list-style-type: none"> <li>▶ Descale appliance (→ section 7.3). <sup>1)</sup></li> <li>▶ Reset error (press and hold on/off button for 3 seconds).</li> <li>If the problem persists:</li> <li>▶ Check sensor resistance [15] (→section 11) and replace the sensor if it is not according to specification. <sup>1)2)</sup></li> </ul>

## Problem solving

Display	Description	Solution
E4	Air temperature inside cabinet above 176 °F (80 °C) or 2 minutes above 158 °F (70 °C). Appliance burner cut off to prevent overheating.	<ul style="list-style-type: none"> <li>▶ Check for flue gas leakage inside the cabinet<sup>1)</sup></li> <li>▶ Reset error (press and hold on/off button for 3 seconds). If the problem persists:</li> <li>▶ Check sensor resistance [18] (→ section 11) and replace the sensor if it is not according to specification.<sup>1) 2)</sup></li> </ul>
E5	Condensing unit flue gas temperature above 428 °F (220 °C) or 2 minutes above 392 °F (200 °C). Appliance burner cut off to prevent overheating.	<ul style="list-style-type: none"> <li>▶ Descale appliance (→ section 7.3).<sup>1)</sup></li> <li>▶ Reset error (press and hold on/off button for 3 seconds). If the problem persists:</li> <li>▶ Check sensor resistance [16] (→ section 11) and replace the sensor if it is not according to specification.<sup>1) 2)</sup></li> </ul>
E7	Electronic control unit internal error.	<ul style="list-style-type: none"> <li>▶ Reset error (press and hold on/off button for 3 seconds). If the problem persists:</li> <li>▶ Replace electronic control unit.<sup>1)</sup></li> </ul>
E8	Error during ionization test. Electronic control unit internal error.	<ul style="list-style-type: none"> <li>▶ Replace electronic control unit.<sup>1)</sup></li> </ul>
E9	Thermal fuse [13] broken.	<ul style="list-style-type: none"> <li>▶ Replace thermal fuse.<sup>1)</sup></li> </ul>
EA <sup>3)</sup>	Ignition failure.	<ul style="list-style-type: none"> <li>▶ Check gas inlet pressure (→ section 4.17).<sup>1)</sup></li> <li>▶ Perform gas and air tuning (→ section 8.11).<sup>1)</sup></li> </ul>
EB	Electronic control unit internal error.	<ul style="list-style-type: none"> <li>▶ Reset error (press and hold on/off button for 3 seconds). If the problem persists:</li> <li>▶ Replace electronic control unit.<sup>1)</sup></li> </ul>
EC	Flame lost during operation.	<ul style="list-style-type: none"> <li>▶ Check gas inlet pressure (→ section 4.17).<sup>1)</sup></li> <li>▶ Perform gas and air tuning (→ section 8.11).<sup>1)</sup></li> </ul>
EE	Gas valve modulation solenoid [7] disconnected.	<ul style="list-style-type: none"> <li>▶ Check gas valve wire connection.<sup>1)</sup> If the problem persists:</li> <li>▶ Replace the gas valve and/or wire connections and/or electronic control unit. For gas valve replacement perform gas and air tuning (→ section 8.11).<sup>1)</sup></li> </ul>
EF	Wrong gas connected (LP instead of NG) for current appliance configuration.	<ul style="list-style-type: none"> <li>▶ Check gas type (→ section 3.3).<sup>1)</sup></li> </ul>
F2 F3 F7 F8	Electronic control unit internal error.	<ul style="list-style-type: none"> <li>▶ Reset error (press and hold on/off button for 3 seconds). If appliance's configuration is required:</li> <li>▶ See section 6.5 to configure appliance (region, power, type and gas type) and perform an automatic combustion adjustment according to the section 8.12.</li> <li>▶ Replace electronic control unit.<sup>1)</sup></li> </ul>

Display	Description	Solution
F9	Gas valve driver internal fault.	<ul style="list-style-type: none"> <li>▶ Check gas valve wire connections.<sup>1)</sup></li> <li>▶ If the problem persists:</li> <li>▶ Replace the wire connections and/or electronic control unit.<sup>1)</sup></li> </ul>
FA	Gas leakage in the gas path (gas valve or gas manifold shut-off valves).	<ul style="list-style-type: none"> <li>▶ Replace the gas valve and/or gas manifold.<sup>1)</sup></li> <li>▶ After gas valve and/or gas manifold replacement perform gas and air tuning (→ section 8.11).<sup>1)</sup></li> </ul>
Display shows   but without existence of solar thermal system.	Power demand lower than appliance minimum output power.	<ul style="list-style-type: none"> <li>▶ Increase hot water flow.</li> <li>▶ Increase setpoint temperature.</li> </ul>
Display shows   and water temperature low.		
High pitch noise (whistling)	Combustion flame with gas in excess or lack of air. (Combustion adjustment is rich).	<ul style="list-style-type: none"> <li>▶ Check if gas type is correct (→ section 3.3).<sup>1)</sup></li> <li>▶ Check gas inlet pressure (→ section 4.17).<sup>1)</sup></li> <li>▶ Perform gas and air tuning (→ section 8.11).<sup>1)</sup></li> </ul>
Low pitch noise with vibration (rumbling)	Combustion flame with air in excess or lack of gas. (Combustion adjustment is lean).	<ul style="list-style-type: none"> <li>▶ Check if gas type is correct (→ section 3.3).<sup>1)</sup></li> <li>▶ Check gas inlet pressure (→ section 4.17).<sup>1)</sup></li> <li>▶ Perform gas and air tuning (→ section 8.11).<sup>1)</sup></li> </ul>

1) only to be carried out by qualified contractors.

2) see temperature resistance charts in fig. 53 and 54.

3) Reset error by closing and opening all water tap, no restriction.

4) Reset error by closing and opening all hot water faucet, limited to 3 times per hour. It can take up to 3 minutes to check for blockage and the appliance to perform the automatic air tuning.

Table 25

Note: If the appliance is locked for safety reasons, information is shown on the display to give more information on the problem. Once the problem is solved, you may have to reset the error (press and hold  button for 3 seconds). To restart the appliance, inside the appliance or in the remote control.

## 10 Electrical diagram

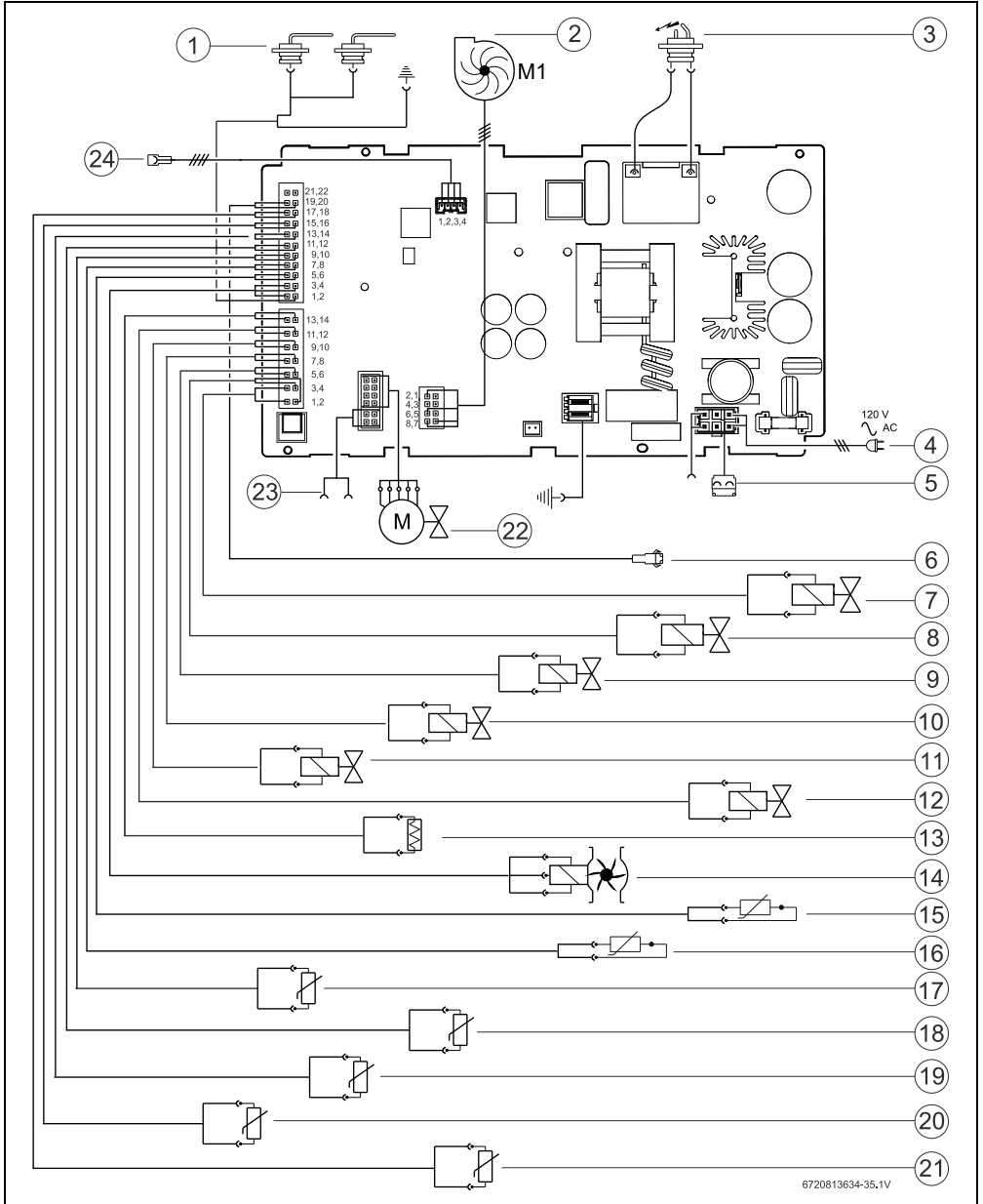

Fig. 52 Electrical diagram



- [1] Ionization sensor
- [2] Fan
- [3] Ignition electrode
- [4] Supply
- [5] Connection for anti freeze kit
- [6] Connection for remote control
- [7] Gas valve - Modulation
- [8] Water bypass valve
- [9] Electrovalve 3
- [10] Electrovalve 1
- [11] Electrovalve 2
- [12] Gas valve - Solenoide safety
- [13] Thermofuse
- [14] Water flow sensor
- [15] Exhaust temperature sensor
- [16] Exhaust temperature sensor - Between chambers
- [17] Water outlet bypass temperature sensor
- [18] Box temperature sensor
- [19] Water outlet HC temperature sensor
- [20] Water inlet temperature sensor
- [21] Tank temperature sensor
- [22] Water valve
- [23] Cascading in/Out
- [24] HMI

### 11 Sensor resistance charts

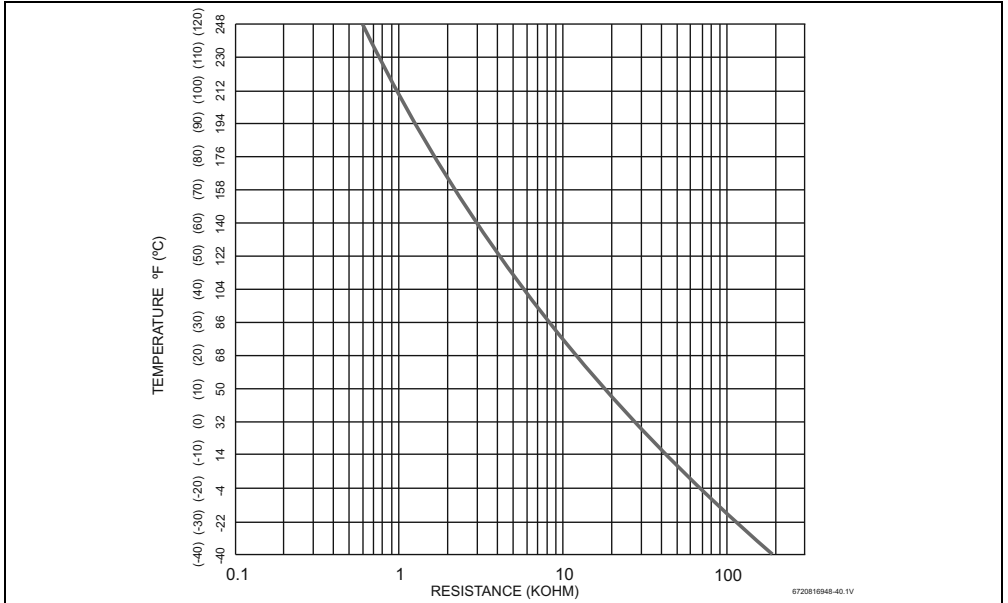

Fig. 53 Outlet / Inlet and heat exchanger immersion sensor characteristics

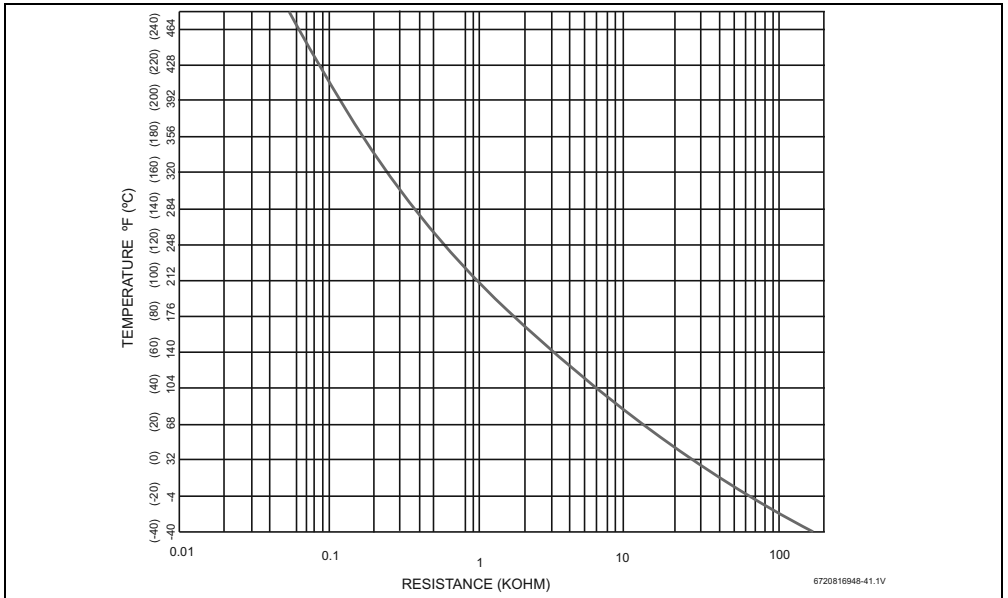

Fig. 54 Back flow and exhaust gas NTC characteristic

## 12 Interior components diagram and parts list

### 12.1 Interior components

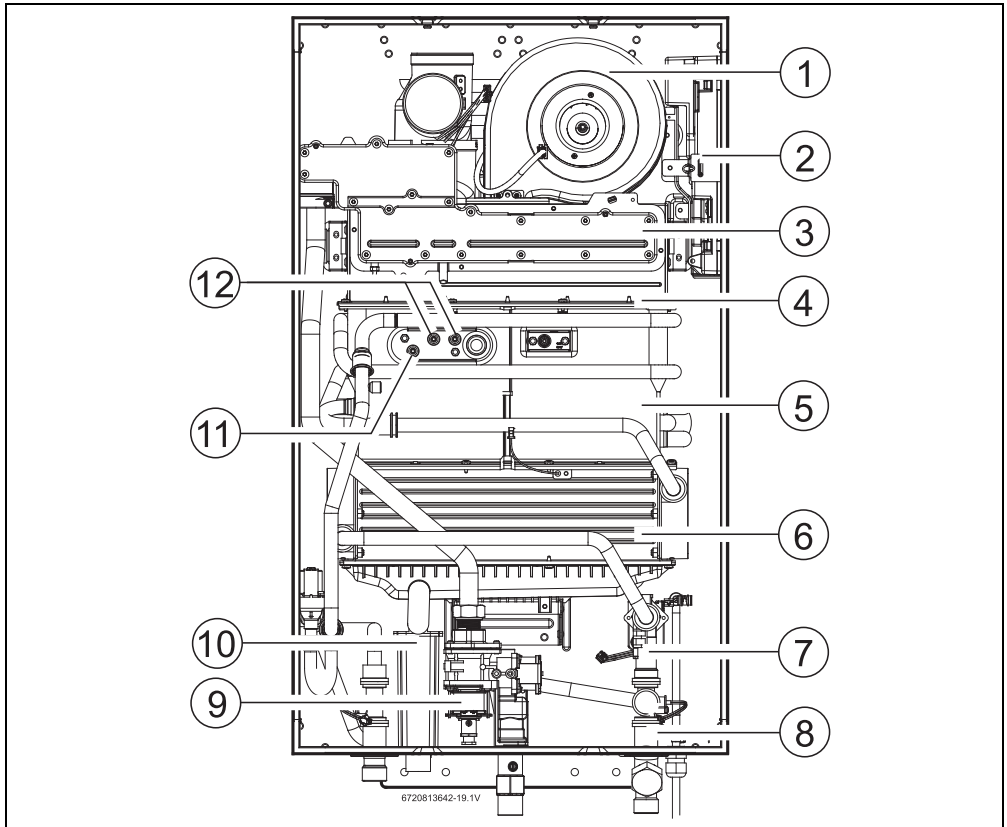

Fig. 55 Components

- [1] Air fan
- [2] Control unit
- [3] Gas manifold
- [4] Burner
- [5] Heat exchanger
- [6] Condensing unit
- [7] Water valve
- [8] By-pass
- [9] Gas valve
- [10] Condensate trap
- [11] Ionization sensor
- [12] Ignition electrodes

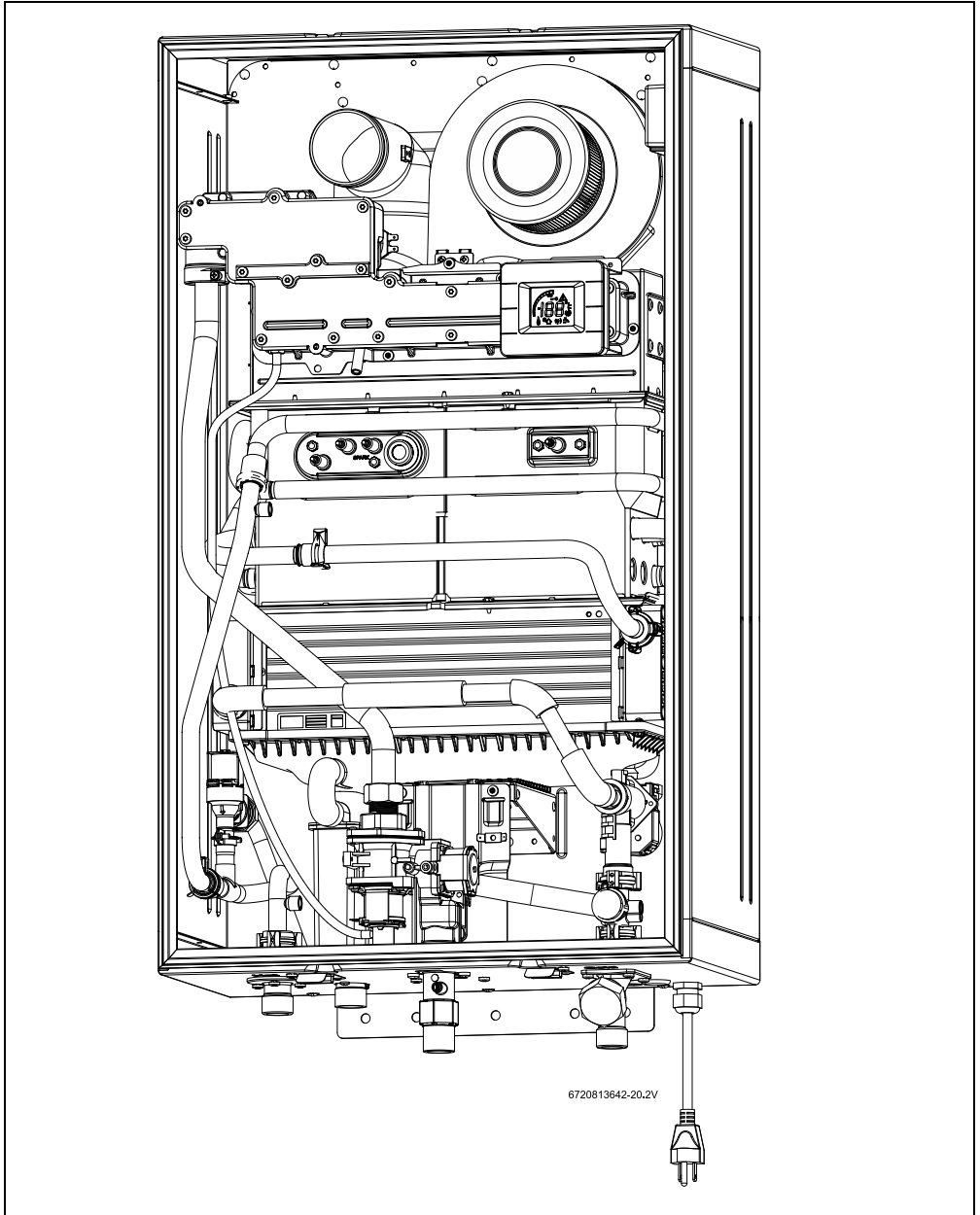



Fig. 56 Appliance overview

## 13 Protecting the environment



### Packing

The packing box may be fully recycled as confirmed by the recycling symbol .

### Components

Many parts in the heater can be fully recycled at the end of the product life. Contact your city authorities for information about the disposal of recyclable products.

### Saving water resources:

- ▶ Make sure you close all the taps after any use. Avoid leaving the taps dripping. Repair any leaking tap.
- ▶ Define the temperature you want, in the appliance or with the remote control. This way you have the precise water flow needed (mixing cold water to regulate temperature will increase the water flow with consequent waste of water).

## 14 Installer Checklist to be completed by installer upon installation



Installation manual should be left with the owner after the installation is tested and completed.

Upon completion of the installation complete the checklist below by answering YES or NO. If any of the answers below are NO, the installation is not complete. Refer to the Installation Manual section referenced below in order to complete the installation. Please contact Technical Support at (866) 330 2730 if additional support is required.

Checklist to be completed by installer			
Water supply	Yes	No	Chapter
Isolation valves installed on water heater inlet and outlet connections	<input type="checkbox"/>	<input type="checkbox"/>	4.10
Water lines flushed and inlet filter cleaned	<input type="checkbox"/>	<input type="checkbox"/>	
Cold water and hot water lines are installed in correct position. (Cold on right, hot on left)	<input type="checkbox"/>	<input type="checkbox"/>	
When the cold supply is turned off no water come out of any hot taps	<input type="checkbox"/>	<input type="checkbox"/>	
Provided PRV installed with proper pipe away to drain	<input type="checkbox"/>	<input type="checkbox"/>	4.9
Water pressure in range	<input type="checkbox"/>	<input type="checkbox"/>	3.2
Water quality requirements in range	<input type="checkbox"/>	<input type="checkbox"/>	4.9
Condensate	Yes	No	Chapter
Condensate drain line installed with neutralizer	<input type="checkbox"/>	<input type="checkbox"/>	
Condensate drain pitched to a drain or to a condensate pump	<input type="checkbox"/>	<input type="checkbox"/>	4.11
Condensate protected from freezing	<input type="checkbox"/>	<input type="checkbox"/>	
Electrical power	Yes	No	Chapter
120 VAC with ground	<input type="checkbox"/>	<input type="checkbox"/>	3.2
Gas supply	Yes	No	Chapter
Shutoff installed on gas supply line	<input type="checkbox"/>	<input type="checkbox"/>	3.2; 4.8; 4.1

**Installer Checklist to be completed by installer upon installation**

<b>Checklist to be completed by installer</b>			
Gas line sized to as needed according to NFPA 54 or CSA B 149	<input type="checkbox"/>	<input type="checkbox"/>	
Gas line leak checked	<input type="checkbox"/>	<input type="checkbox"/>	
If an LP conversion is the LP kit installed	<input type="checkbox"/>	<input type="checkbox"/>	4.6.2
Gas pressure in range	<input type="checkbox"/>	<input type="checkbox"/>	3.2
<b>Serial number</b>			
Serial number is located on the rating plate which is located on the left side (when facing appliance front) of the cover.			
<b>General</b>	<b>Yes</b>	<b>No</b>	
Manual given to customer or left with the water heater	<input type="checkbox"/>	<input type="checkbox"/>	
Installation date:			
Installing company name:			
Address:			
Phone:			

Table 26

## 15 Software main menu structure

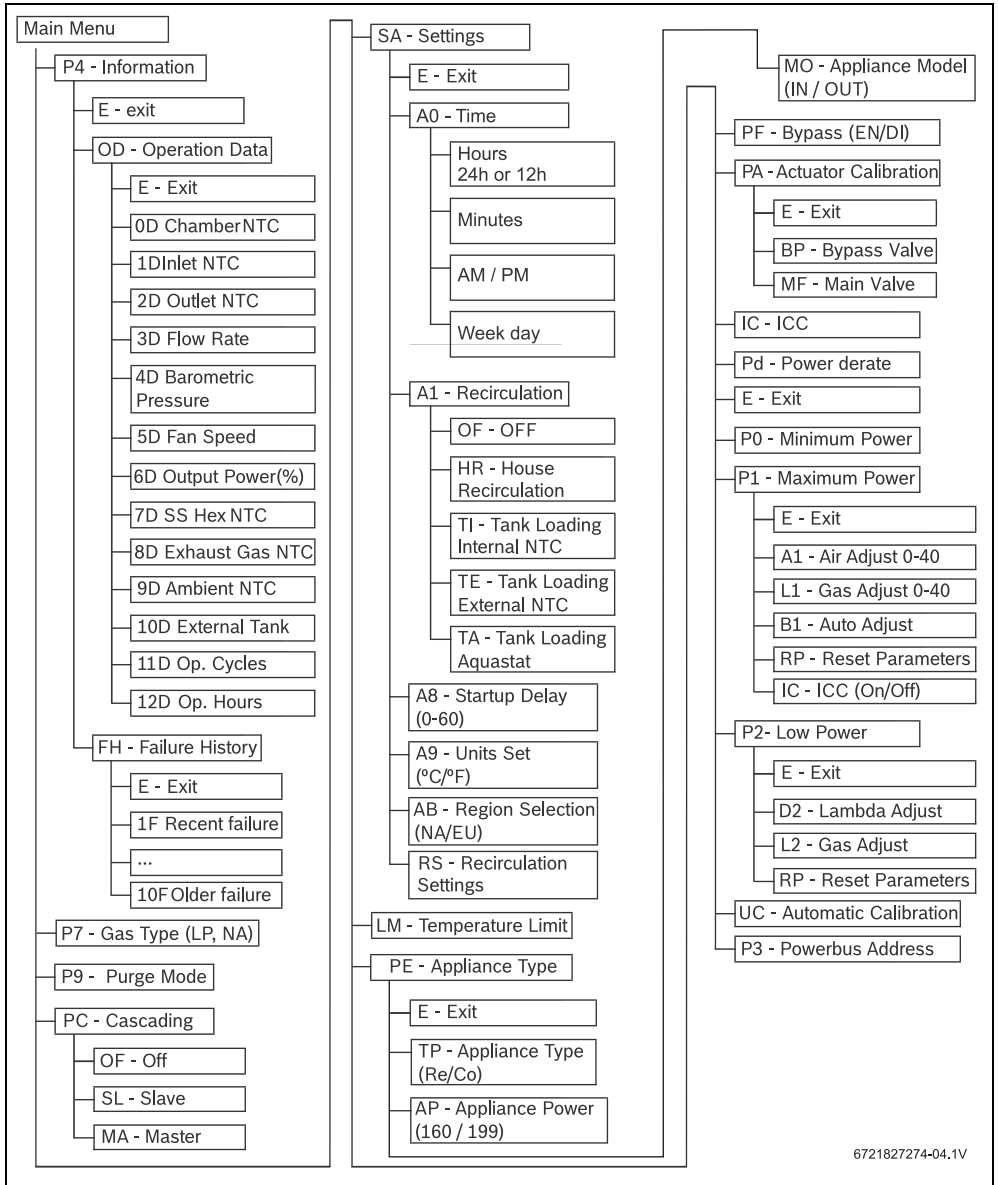

Fig. 57

16 LIMITED TANKLESS HEATER WARRANTY

BRADFORD WHITE CORPORATION

LIMITED INFINITI TANKLESS® K- or L-SERIES WATER HEATER WARRANTY

WHAT DOES THIS LIMITED WARRANTY COVER?

This limited warranty covers both the heat exchanger and component parts for leakage or other malfunction caused by defects in materials and/or workmanship. It applies to the original consumer purchaser and to any subsequent owner as long as the heater remains installed at its original place of installation.

WHAT DOES THIS LIMITED WARRANTY NOT COVER?\*

- 1. This limited warranty does not cover leakage or other malfunctions caused by:
a) Defective installation, specifically, any installation which is made:
i) in violation of applicable state or local plumbing, housing or building codes, or
ii) without a certified American Gas Association, ASME, or comparable pressure relief valve, or
iii) contrary to the written instructions furnished with the unit.
b) Adverse local conditions, specifically sediment or lime precipitate in the heat exchanger; corrosive elements in the atmosphere; or water quality contrary to the written requirements furnished with the unit.
c) Misuse, specifically operations and/or maintenance contrary to the written instructions furnished with the unit, anode removal (if provided), disconnection, alteration or addition of non-approved components or apparatus, operation at settings other than those set forth on the rating plate, or accidental or other exterior damage.
2. This warranty also does not cover:
a) Production of noise, taste, odors, discoloration or rusty water.
b) Incidental property damage, loss of use, inconvenience or other incidental or consequential costs.
c) Costs associated with the replacement and/or repair of the unit, including:
i) any freight, shipping or delivery charges
ii) any removal, installation or re-installation charges
iii) any material, and/or permits required for installation, re-installation or repair
iv) charges to return the defective heater and/or component part to the manufacturer.

WHAT IS THE PERIOD OF COVERAGE?

This limited warranty runs from date of installation (or without proof of installation, from three (3) months after the date of manufacture) for the period specified on the following table.

FIFTEEN YEAR LIMITED HEAT EXCHANGER WARRANTY\*

A no charge\* replacement will be provided in the event of a covered failure of the Heat Exchanger.

FIVE YEAR LIMITED PARTS WARRANTY\*

All other parts not referenced above are covered for five years from date of original installation.

\*Note: Limited heat exchanger warranty fifteen (15) years or 8,000 operational hours; whichever is shorter. Limited parts warranty is five (5) years or 8,000 operational hours; whichever is shorter. A warranty product or part is provided exclusive of labor, freight and/or any installation costs. Any product used for other than a single-family housing unit application will be warranted for only eight (8) years on heat exchanger and five (5) year on parts regardless of any other warranty period specified. All replacement heaters and parts carry the balance of the original warranty, i.e. if an original fifteen (15) year warranted heater develops a leak due to defects in materials/workmanship after only eight (8) years and 5,000 operational hours, the replacement unit is warranted for seven (7) years and 3,000 operational hours in this example.

WHAT IS THE DURATION OF THE IMPLIED WARRANTY?

ANY IMPLIED WARRANTIES, INCLUDING THE WARRANTY OF MERCHANTABILITY IMPOSED ON THE SALE OF THE WATER HEATER UNDER THE LAWS OF THE STATE OF SALE ARE LIMITED IN DURATION TO ONE YEAR FROM DATE OF ORIGINAL INSTALLATION.

HOW DOES STATE LAW RELATE TO THE WARRANTY?

- Some states DO NOT allow:
1. Limitations on how long an implied warranty lasts.
2. Limitations on incidental or consequential damages.

Therefore, the above limitations or exclusions may not apply to you.

This warranty gives you specific legal rights, and you may also have other rights which vary from state to state.

\*\*Restrictions are not applicable to implied warranties in California. See "Special State Provisions" on reverse side.

238-53321-00D (6/21)



**LIMITED TANKLESS HEATER WARRANTY (CONTINUED)**

**WHAT WILL WE DO TO CORRECT PROBLEMS?**

1. If a defect occurs within the heat exchanger warranty period, we will:  
Provide a replacement heat exchanger of our manufacture (or at our option) repair any unit which develops a leak in the heat exchanger within the warranty period. To obtain a replacement, you must forward both the rating plate from the defective unit to us and a copy of the original sales receipt. If government regulations require the replacement heat exchanger to have features not found in the defective heat exchanger, you will be required to pay the difference in price represented by those government required features.
2. If a defect occurs within the parts warranty period, we will:  
Provide a replacement part (or at our option repair) any part which fails to function within the parts warranty period. To obtain a replacement, you must forward the defective part to us. If government regulations require the replacement part to have features not found in the defective part, you will be required to pay the difference in price represented by those government required features.

We do reserve the right to verify any claims of defect by inspection.

**WHAT WILL WE NOT DO?**

We will not:

1. Repair or replace any heater or part subject to conditions outlined in "What Does This Limited Warranty Not Cover?"
2. Reimburse any costs associated with repair and/or replacement.
3. Replace and/or repair any heater without complete model/serial number.
4. Replace any heater without prior receipt of actual rating plate from appliance and copy of original sales receipt.

**HOW DO YOU GET WARRANTY ASSISTANCE?**

Upon discovering a defect or problem, you should:

1. Contact either the Installer or dealer, or
2. Contact us--  
BRADFORD WHITE CORPORATION  
WARRANTY SUPPORT GROUP  
445 EAGLE DR.  
MIDDLEVILLE, MI 49333  
1-800-531-2111

Please have model number and serial number ready.

**WHAT SHOULD YOU DO TO KEEP THE WARRANTY IN EFFECT?**

To facilitate warranty assistance, you should:

1. Follow all instructions enclosed with the product.
2. Retain all bills of sale or receipts for proof of installation, etc.
3. Contact your installer, dealer or our Warranty Department as soon as any problem or defect is noticed.
4. When necessary, allow us, or our chosen representative, to inspect the unit.
5. For your reference, fill in the Model and Serial Number found on the units Rating Plate:

Model Number

Serial Number

Date of Installation

Name of Installer

**SPECIAL STATE PROVISIONS**

For heaters installed in California or Oregon, paragraphs 2(c) (i) (iv) of the section "WHAT DOES THIS WARRANTY NOT COVER?" does NOT apply.  
All other terms and conditions of this warranty apply as stated.

**PLEASE RETAIN THIS WARRANTY IN A SAFE LOCATION FOR FUTURE REFERENCE**

238-53321-00D (6/21)

Fig. 59







6720813642



**BRADFORD WHITE<sup>®</sup>**  
W A T E R H E A T E R S

Ambler, PA

For U.S. and Canada field service,  
Contact your professional installer or  
local Bradford White representative.

Sales/**800-523-2931**  
Fax/**215-641-1670**  
Parts Fax/**215-641-2180**

Technical Support/**800-334-3393**  
Fax/**269-795-1089**

Warranty/**800-531-2111**  
Fax/**269-795-1089**

**International:**  
Telephone/**215-641-9400**  
Telefax/**215-641-9750**



**BRADFORD WHITE-CANADA<sup>™</sup> INC.**  
A SUBSIDIARY OF BRADFORD WHITE CORPORATION

Mississauga, ON

Sales/**866-690-0961**  
**905-203-0600**

Fax/**905-636-0666**  
Technical Support/**800-334-3393**

Email  
parts@bradfordwhite.com  
techserv@bradfordwhite.com

www.bradfordwhite.com