

Fresh In™

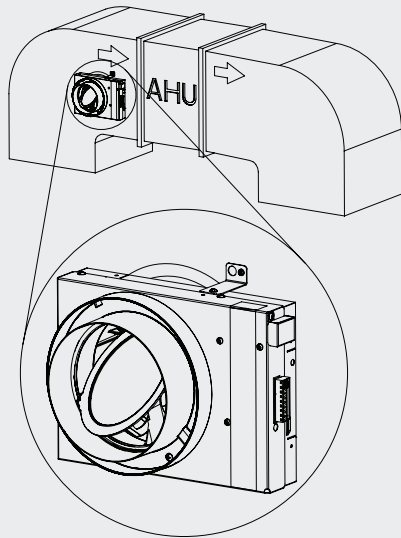

Unequaled Installation Flexibility

DIRECT TO AHU



Fresh In™ Motorized Supply Damper

Smart, Simple, and Easy to Install

The Broan® Fresh In™ FIN-6MD is a smart, motorized supply damper that controls the fresh air entering the home's air handling unit. By continually monitoring the last 48 hours of outdoor temperature and humidity levels, the unit is able to estimate the best time of day to allow fresh air into the home. It's the smart way to ensure ventilation, balanced with homeowner comfort. The FIN-6MD can be easily installed in the conventional inline configuration or be mounted directly to the AHU to save space and reduce installation time.

Advantages vs. the Competition

- Integrated humidity and temperature monitoring does not require a separate controller to be installed
- Five selectable comfort modes to best suit the climate zone
- Reduced installation time with direct to AHU mounting capability
- Galvannealed steel box construction and protected electronics for added durability during installation

Inline Mounting Options

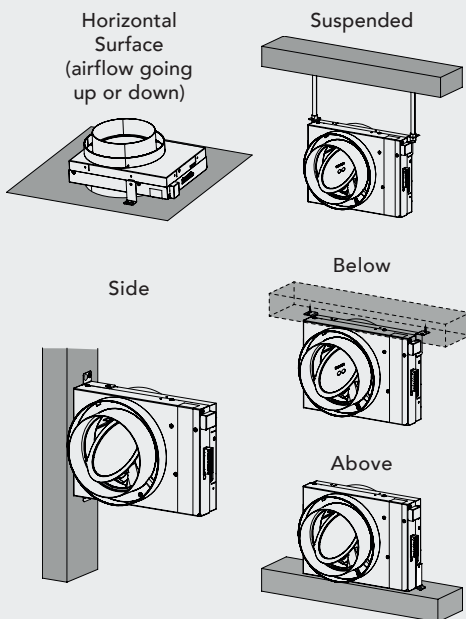

SPECIFICATIONS

Model Name	Broan Fresh In™ FIN-6MD
Unit Intelligence	Outdoor Temperature & Humidity Monitoring
Damper	Motorized Control
Installation	Conventional Inline or Direct to AHU
Duct Diameter	6" Round
Electrical	24 Volt / 60 HZ
Construction	24ga Galvannealed Steel Box Structure
Warranty	5 Years

For more information on Fresh In™ technology, visit Broan-NuTone.com.