

## Utility Workshop Vises (Swivel Base)

Heavy-duty design strengthens this ideal utility workshop vise. Cast vises with pipe jaws, anvil and horn feature a swivel base with positive locking in addition to replaceable, hardened steel, serrated jaw facings for user convenience.

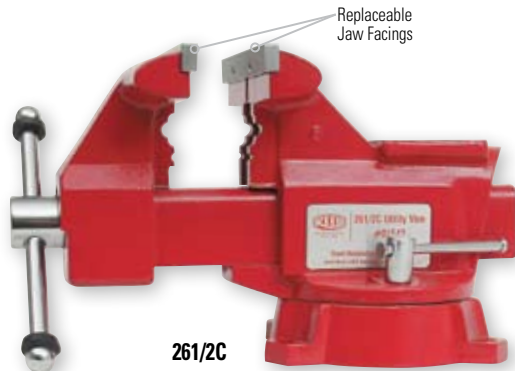

261/2C

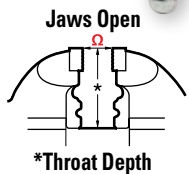

Catalog No.	Item Code	Throat Depth*		Jaw Width		Jaws Open <sup>Ω</sup>		Weight	
		in	mm	in	mm	in	mm	lbs	kg
241/2C	01522	2 1/2	64	4 1/2	115	4	102	18.0	8.2
251/2C	01532	3	76	5 1/2	140	5	127	27.0	12.3
261/2C	01542	3 3/8	86	6 1/2	165	6	152	41.0	18.6
26B	01545	4 3/16	120	6	150	6	152	60.0	27.3

\*See illustration  
<sup>Ω</sup>See illustration

## Mid-Line Vises

A vise of strength and price between the Machinist vise and Utility vise. Design features a machined work surface. The main screw and nut are totally enclosed to keep out dirt and eliminate wear. Vise has replaceable, hardened steel jaw facings and pipe jaws, along with two swivel-base side clamps for a positive lock.

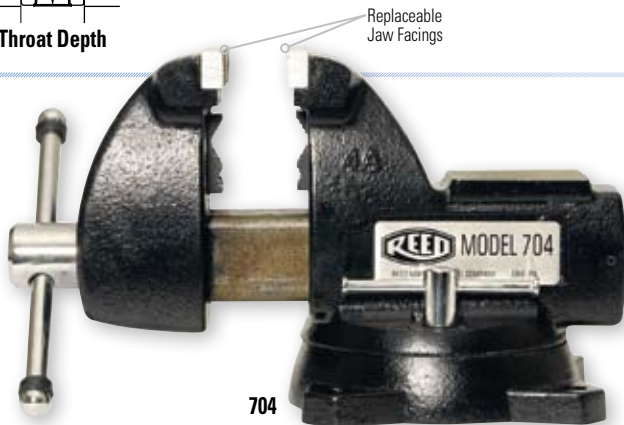

704

Catalog No.	Item Code	Throat Depth*		Jaw Width		Jaws Open <sup>Ω</sup>		Pipe Capacity In-Nom.	Weight	
		in	mm	in	mm	in	mm		lbs	kg
704	01385	3.45	88	4	102	4.5	114	1/2 - 2	36.0	16.4
705	01387	3.75	95	5	127	5.5	140	1/4 - 2 1/2	47.0	21.4
706	01389	4.10	104	6	152	5.7	146	1/4 - 3 1/2	61.0	27.7

\*See illustration  
<sup>Ω</sup>See illustration

**✓ WHY REED?**  
 Vises have enclosed screw assembly for all-weather protection.

Swivel-base models feature positive-locking base.

## Combination Bench & Pipe Vises (Swivel Base)

Designed to provide decades of service, these cast vises carry Reed's lifetime warranty. Steel pipe jaws made of heat-treated, hardened steel are reversible and replaceable, and jaw facings are replaceable, too. This yields long jaw life. Vises are designed with maximum throat depth for greater clamping action to hold large parts. Forged steel, geared clamp bolt on swivel base maintains positive lock to avoid slippage under heavy pressure.

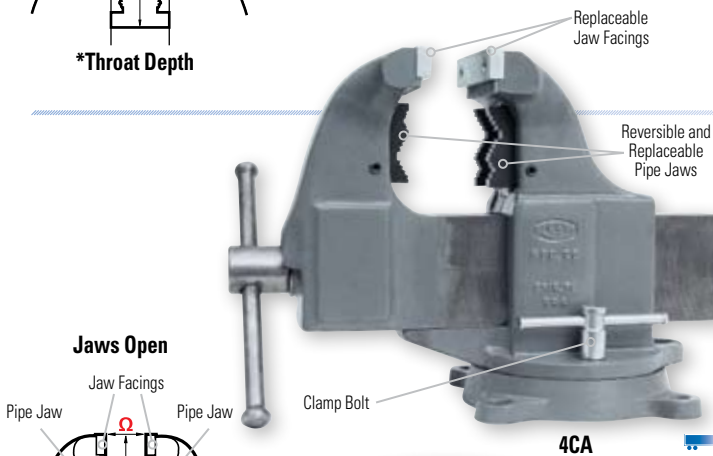

4CA

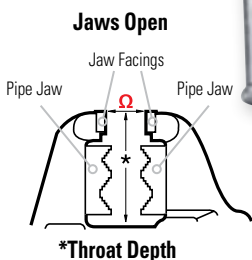

Catalog No.	Item Code	Throat Depth*		Jaw Width		Jaws Open <sup>Ω</sup>		Pipe Capacity In-Nom.	Weight	
		in	mm	in	mm	in	mm		lbs	kg
1CA	01350	4	102	3 1/2	89	4	102	1/8 - 2 1/2	35.0	15.9
2CA	01360	5 3/8	137	4 1/2	114	5	127	1/8 - 3 1/2	60.0	27.3
3CA	01370	6 1/4	159	5	127	6	152	1/8 - 4 1/2	95.0	43.2
4CA	01380	7 1/8	181	6	152	10	254	1/8 - 6	157.0	71.4

\*See illustration  
<sup>Ω</sup>See illustration

Swivel-base models feature positive-locking base.

**✓ WHY REED?**

Only Reed has backed up its bench vises with a Lifetime Warranty for over 110 years.

